

**REGIONAL SCALE NODES
PRIMARY INFRASTRUCTURE

TECHNICAL SPECIFICATIONS**

October 2, 2009

RSN Technical Specifications

TABLE OF CONTENTS

1	INTRODUCTION	11
1.1	GENERAL	11
1.2	DEFINITIONS	11
1.3	SPECIAL TECHNICAL INSTRUCTIONS	12
2	GENERAL SYSTEM DESCRIPTION	14
2.1	OVERVIEW	14
2.2	CABLE NETWORK SYSTEM	15
2.3	PRIMARY NODE GENERAL DESCRIPTION	16
2.4	COMMUNICATION SYSTEM	17
2.5	POWER SUBSYSTEM	18
2.6	MANAGEMENT SUBSYSTEM	21
2.7	WORK SCOPE	22
2.7.1	<i>Work Inclusions</i>	22
2.7.2	<i>Work Exclusions</i>	23
3	GENERAL TECHNICAL REQUIREMENTS	24
3.1	GENERAL TRANSMISSION REQUIREMENTS	24
3.1.1	<i>General Margin Requirements</i>	24
3.2	COMPLIANCE TO STANDARDS	24
3.2.1	<i>Standards</i>	24
3.2.2	<i>Environmental Conditions for Submarine Equipment</i>	24
3.2.3	<i>Local Standards</i>	24
3.2.4	<i>Safety Overview</i>	25
3.3	RELIABILITY AND AVAILABILITY	26
3.3.1	<i>Primary Infrastructure Reliability Requirement</i>	26
3.3.2	<i>Overall Reliability Calculation</i>	26
3.3.3	<i>Calculation Methodology</i>	26
3.3.4	<i>Failure Rate Analysis for Subsystem Components</i>	26
3.3.5	<i>Primary Infrastructure Availability</i>	26
3.4	COMPONENTS TRACEABILITY	26
3.5	TRANSMISSION PATH IDENTIFICATION	27
3.6	EQUIPMENT ALARMS	27
3.6.1	<i>List of Alarms</i>	27
3.6.2	<i>Cable Station Alarms</i>	27
3.6.3	<i>External Interfaces for Alarms</i>	27
3.6.4	<i>Housekeeping Alarms</i>	27
3.7	MANAGEMENT EQUIPMENT GENERAL REQUIREMENTS	27
3.7.1	<i>General</i>	27
3.7.2	<i>Integration</i>	27
3.7.3	<i>In-service Capabilities</i>	28
3.7.4	<i>Out-of-service Capabilities</i>	28
3.7.5	<i>Interfaces with Transmission/PFE Equipment</i>	28
3.7.6	<i>Impact on Transmission Performance</i>	28
3.7.7	<i>Access Diversity</i>	28
3.7.8	<i>Data Storage</i>	28
3.7.9	<i>Data Safekeeping and Retrieval</i>	29
3.7.10	<i>Time Stamping</i>	29
3.8	GENERAL POWERING REQUIREMENTS	29
3.8.1	<i>DC Voltage</i>	29
3.8.2	<i>High Voltage Rating</i>	29

RSN Technical Specifications

3.8.3	<i>Modes of Operation (I/V Functions)</i>	29
3.8.4	<i>Surge Protection Features (including branching units if applicable)</i>	30
3.9	SAFETY FEATURES	30
3.10	MAINTENANCE FEATURES (INCLUDING FEATURES TO FACILITATE CABLE FAULT REPAIRS)	30
3.11	NAMING, LABELS AND NUMBERING	30
3.12	COLORS	30
3.13	TEST EQUIPMENT.....	30
3.13.1	<i>Transmission Test Equipment</i>	30
3.13.2	<i>Fault Localization Test Equipment</i>	30
3.13.3	<i>Power Test Equipment</i>	31
3.14	TOOLS.....	31
3.15	SPARES	31
4	TRANSMISSION PERFORMANCE.....	32
4.1	END-TO-END PERFORMANCE.....	32
4.1.1	<i>Power/Impairment Budget Template</i>	32
4.1.2	<i>BER Objective</i>	32
4.1.3	<i>Transmission Capacity</i>	32
4.1.4	<i>Minimum Optical Loading (if applicable)</i>	32
4.2	OPTICAL POWER BUDGET	33
4.2.1	<i>Start-of-Life Q-Margin</i>	33
4.2.2	<i>End-of-Life Margin</i>	33
4.2.3	<i>Repair Margin</i>	33
4.2.4	<i>Margin for Monitoring Signals</i>	33
4.2.5	<i>Other Margins</i>	33
4.3	DISPERSION COMPENSATION STRATEGY	33
4.4	SYSTEM TRANSMISSION INTERFACES	34
4.4.1	<i>Optical Power levels</i>	34
4.4.2	<i>Optical Return Loss</i>	34
4.4.3	<i>Optical Connectors</i>	34
4.4.4	<i>Input Wavelength Range</i>	34
4.5	TRIBUTARY INDEPENDENCE	34
4.6	TIMING AND SYNCHRONIZATION.....	34
4.6.1	<i>Timing Modes</i>	34
4.6.2	<i>Timing Source Switching (if applicable)</i>	34
4.6.3	<i>Effect of Timing Source Switching on Transmission Performance</i>	35
5	SUBMARINE EQUIPMENT	36
5.1	SUBMARINE OPTICAL AMPLIFIERS (“REPEATERS”).....	36
5.1.1	<i>Detailed Description</i>	36
5.1.2	<i>Repeater Types</i>	36
5.1.3	<i>Performance History or Technology Demonstration</i>	36
5.1.4	<i>Mechanical Requirements</i>	37
5.1.5	<i>Optical Requirements</i>	39
5.1.6	<i>Management Requirements</i>	40
5.1.7	<i>Reliability</i>	41
5.1.8	<i>Qualification Data</i>	41
5.1.9	<i>Fault localization</i>	41
5.1.10	<i>Identification of Repeater Housing</i>	41
5.1.11	<i>Marking Quality</i>	41
5.1.12	<i>Traceability</i>	41
5.1.13	<i>Failure Modes</i>	42
5.1.14	<i>Spares</i>	42
5.2	SUBMARINE EQUALIZERS (IF REQUIRED).....	42
5.3	SUBMARINE CABLE PLANT.....	42

RSN Technical Specifications

5.3.1	Definition of the System SLD	42
5.3.2	Basic System SLD.....	43
5.3.3	Dispersion Management	43
5.3.4	Burial Requirements	44
5.3.5	Repair Allowances	44
5.4	CABLE	45
5.4.1	Performance.....	45
5.4.2	General Requirements.....	45
5.4.3	Cable Structure	46
5.4.4	Cable Types.....	46
5.4.5	Operating Temperature Range	47
5.4.6	Cable Transportation and Storage	47
5.4.7	Cable Breaks and Repair	48
5.4.8	Water and Gaseous Ingress	48
5.4.9	Power Feed Conductor	48
5.4.10	Hydrogen and Radiation Effects	49
5.4.11	Fibers Identification.....	49
5.4.12	Cable Markers.....	50
5.4.13	General Mechanical Requirements.....	50
5.4.14	Cable Tensile Strength	51
5.4.15	Localization of Damage	52
5.4.16	Reverse Bend Performance	53
5.4.17	Station and Land Cable Minimum Bend Requirement.....	53
5.4.18	Abrasion Resistance	53
5.4.19	Corrosion Resistance	53
5.4.20	Crushing and Impact Performance.....	53
5.4.21	Torsion Performance.....	53
5.4.22	Coiling.....	53
5.4.23	Land Cable Actinic Radiation Protection.....	54
5.4.24	Cable Finish	54
5.4.25	Cable Joints and Jointing Requirements.....	54
5.4.26	Optical Fibers Requirements	55
5.4.27	Spares.....	56
5.5	SUBMARINE BRANCHING UNIT (IF REQUIRED).....	56
5.6	PRIMARY NODE	56
5.6.1	Overview	56
5.6.2	Primary Node Input Port	57
5.6.3	Primary Node Expansion Ports	58
5.6.3.1	Primary Node Expansion Ports.....	58
5.6.4	Primary Node Science Port.....	60
5.6.5	High-Bandwidth Science Port Description.....	62
5.6.6	Reliability.....	64
5.6.7	Performance History or Technology Demonstration.....	65
5.6.8	Mechanical Requirements.....	65
5.6.9	Other Design Guidelines.....	68
5.6.10	Management Requirements	69
5.6.11	Testing.....	70
6	TERMINAL STATION EQUIPMENT (TSE)	72
6.1	GENERAL TERMINAL STATION EQUIPMENT REQUIREMENTS	72
6.1.1	Design Life and Reliability	72
6.1.2	Automatic Switching of Redundant Equipment.....	72
6.1.3	Software Requirements	72
6.1.4	Unit Removal Detection	74
6.1.5	Thermal Management (fans, etc.)	75

RSN Technical Specifications

6.1.6	<i>Ambient Conditions</i>	75
6.1.7	<i>EMC/ESD Conditions</i>	76
6.1.8	<i>Shock and Vibration</i>	77
6.1.9	<i>Marking, Face Layout and Designations</i>	77
6.1.10	<i>Equipment Status Indication</i>	78
6.1.11	<i>Connection to the Station Alarm System</i>	79
6.1.12	<i>Remote Terminal Station Indication</i>	79
6.1.13	<i>Supervision of Equipment</i>	79
6.1.14	<i>Power Supplies</i>	80
6.1.15	<i>Construction Practices</i>	80
6.1.16	<i>Equipment Fault Location and Repair</i>	80
6.1.17	<i>Safeguards to Service</i>	80
6.1.18	<i>Remote operation of the Terminal Station Equipment</i>	81
6.1.19	<i>Craft Terminal</i>	81
6.1.20	<i>Supervisory and Alarm Arrangements</i>	81
6.1.21	<i>Other Requirements</i>	82
6.1.22	<i>Protection of Operating Personnel</i>	83
6.1.23	<i>Earthing and Bonding</i>	83
6.2	TRANSMISSION TERMINAL EQUIPMENT (SLTE).....	83
6.2.1	<i>Scope</i>	83
6.2.2	<i>Architecture</i>	83
6.2.3	<i>Redundancy Architecture Availability</i>	83
6.2.4	<i>Dispersion Compensation Support</i>	83
6.2.5	<i>Management Interfaces</i>	83
6.2.6	<i>Signal Interfaces</i>	84
6.2.7	<i>Power Dissipation per wavelength</i>	84
6.2.8	<i>AIS Generation and Handling</i>	84
6.2.9	<i>ALS and APR (Automatic Laser Shutdown and Automatic Power Reduction)</i>	84
6.2.10	<i>Integrated Test Equipment</i>	84
6.2.11	<i>Transmission Tolerance to Management Sub-system Failure</i>	84
6.2.12	<i>Transmission Tolerance to Cards Insertion/Removal (In-service)</i>	84
6.2.13	<i>Performance Monitoring Support</i>	85
6.2.14	<i>Performance</i>	85
6.3	MANAGEMENT TERMINAL EQUIPMENT (MTE).....	85
6.3.1	<i>Scope</i>	85
6.3.2	<i>Architecture</i>	86
6.3.3	<i>Future Proofing</i>	86
6.3.4	<i>Backdoor Access</i>	86
6.3.5	<i>Equipment</i>	86
6.3.6	<i>Integration with "Standard" IT Equipment</i>	86
6.3.7	<i>Types of Power Feeds, Power Redundancy</i>	86
6.3.8	<i>Power Dissipation (typical)</i>	86
6.3.9	<i>Submersible Plant Supervision</i>	87
6.3.10	<i>Terminal Equipment Supervision</i>	87
6.3.11	<i>MTE Redundancy</i>	87
6.3.12	<i>Alarm and Performance Information Acquired by the MTE</i>	87
6.3.13	<i>Alarm Masking</i>	88
6.3.14	<i>Control Required by the MTE</i>	88
6.3.15	<i>Event Management</i>	88
6.3.16	<i>Performance Management</i>	90
6.3.17	<i>Configuration Management</i>	90
6.3.18	<i>Security Management</i>	90
6.3.19	<i>Terminal/Workstation to MTE Interface</i>	90
6.3.20	<i>Human Computer Interface (HCI)</i>	91
6.4	SYSTEM TO SYSTEM INTERFACE FOR MTE.....	92

RSN Technical Specifications

6.4.1	General.....	92
6.4.2	System to System Interface.....	92
6.5	SOFTWARE.....	93
6.6	SUBMARINE SYSTEM POWER FEED EQUIPMENT.....	94
6.6.1	Scope.....	94
6.6.2	Redundancy.....	94
6.6.3	Construction.....	94
6.6.4	Design Life and Reliability.....	97
6.6.5	Protection of Personnel.....	97
6.6.6	Protection of the Submarine System.....	98
6.6.7	Powering of the Submarine System.....	98
6.6.8	Management, Monitoring and Alarms.....	99
6.6.9	Earth Connections.....	103
6.6.10	Ocean Ground Bed Electrodes System.....	104
6.6.11	Dummy Load.....	104
6.6.12	Cable Electroding.....	104
6.6.13	PFE Performance.....	105
6.6.14	Security of Service.....	106
7	ASSEMBLY, LOADING AND LAYING OF THE SUBMERSIBLE PLANT.....	107
7.1	GENERAL.....	107
7.2	ASSEMBLY OF THE SUBMERSIBLE PLANT.....	107
7.3	JOINTING.....	108
7.3.1	Jointers' Qualification.....	108
7.3.2	Supervision and Jointing Operations.....	108
7.3.3	Jointing Specifications.....	108
7.3.4	Completion of Shipboard Testing.....	108
7.4	LOADING AND LAYING OF THE SUBMERSIBLE PLANT.....	108
7.4.1	General.....	108
7.4.2	Cable Ship Requirements.....	109
7.4.3	Other Requirements.....	111
7.4.4	Information to be provided by the Contractor.....	111
7.4.5	Equipment to be provided by the Contractor on Board of the Laying Ship.....	112
7.4.6	Loading and Laying Procedures.....	112
7.4.7	Auxiliary Facilities.....	112
7.4.8	Damage during Loading and Transit.....	112
7.4.9	Damage during Laying.....	112
7.4.10	Security during Laying.....	113
7.5	TESTING DURING LOADING.....	113
7.5.1	Tests.....	113
7.5.2	Test Results.....	113
7.5.3	Purchaser Tests.....	113
7.5.4	Testing During Laying Operation.....	114
7.6	CABLE ROUTE CLEARANCE OPERATIONS.....	114
7.6.1	General.....	114
7.6.2	Objectives.....	114
7.6.3	Activities.....	114
7.7	CABLE BURYING.....	116
7.7.1	Pre-Lay Grapple Run.....	116
7.7.2	Burial by Plow.....	116
7.7.3	Post Lay Burial Operations.....	117
7.7.4	Post Lay Inspection.....	117
7.7.5	General Requirements.....	117
7.8	CABLE SHORE END INSPECTION.....	119
7.9	BEACH WORKS.....	119

RSN Technical Specifications

7.10	PIPELINE CROSSING	119
7.11	CABLE CROSSING	119
7.12	CALIBRATION OF EQUIPMENT.....	120
8	TERMINAL STATION EQUIPMENT INSTALLATION.....	121
8.1	GENERAL.....	121
8.2	SCOPE OF WORK.....	121
8.3	GENERAL LAYOUT OF STATIONS.....	121
8.4	IN-STATION INSPECTION	121
8.5	SAFETY	122
8.6	IN-STATION TESTING.....	122
8.7	LAND CABLE SECTION	122
8.8	RETURN EARTH SYSTEM.....	122
8.9	CIVIL WORKS (DUCTS, MAN-HOLE, BEACH MAN-HOLE).....	122
8.10	AS-BUILT DRAWINGS	122
9	ACCEPTANCE REQUIREMENTS	123
9.1	GENERAL.....	123
9.2	PROVISIONAL ACCEPTANCE (PA).....	123
9.2.1	<i>Issuance of System Provisional Acceptance Certificate</i>	<i>123</i>
9.2.2	<i>Certificate of Service.....</i>	<i>124</i>
9.3	SYSTEM ACCEPTANCE HANDBOOK TEMPLATE	124
9.4	ACCEPTANCE TEST PERIODS	125
9.4.1	<i>Period I: Product Design Acceptance Testing.....</i>	<i>125</i>
9.4.2	<i>Period II: Factory Acceptance and Submerged Plant Assembly Testing</i>	<i>126</i>
9.4.3	<i>Period III.A: Terminal Equipment In-Station Testing</i>	<i>126</i>
9.4.4	<i>Period III.B: Loading and Laying Tests</i>	<i>127</i>
9.4.5	<i>Period IV: Transmission Segments Contractor's Test Period</i>	<i>127</i>
9.4.6	<i>Period V: Purchaser Transmission Segments Test Period</i>	<i>128</i>
9.4.7	<i>Period VI - Out of Service Confidence Trial.....</i>	<i>128</i>
9.4.8	<i>Period VII: System Integration Test Period.....</i>	<i>129</i>
9.4.9	<i>Period VIII: Purchaser System Test Period.....</i>	<i>130</i>
9.4.10	<i>Additional Tests.....</i>	<i>131</i>
9.4.11	<i>Reference Data</i>	<i>131</i>
9.4.12	<i>Period IX - System Out of Service Confidence Trial.....</i>	<i>131</i>
9.5	ACCEPTANCE TESTS REPORTING.....	132
9.5.1	<i>Provisional Report:</i>	<i>132</i>
9.5.2	<i>Final Report</i>	<i>132</i>
9.6	FINAL ACCEPTANCE	133
9.6.1	<i>Purchaser Test Period for Final Acceptance.....</i>	<i>133</i>
9.6.2	<i>Issuance of Certificate of Final Acceptance</i>	<i>133</i>
10	FAULT LOCALIZATION, REPAIR METHOD AND SPARES	134
10.1	FAULT LOCALIZATION.....	134
10.2	ELECTRODING.....	135
10.3	DC TESTING	135
10.4	REPAIR TECHNIQUES	135
10.5	MAINTENANCE AND FAULT LOCATION TEST EQUIPMENT.....	136
10.5.1	<i>Maintenance, Test Location and Testing Equipment for Cable Ship and Depots</i>	<i>136</i>
10.5.2	<i>Maintenance, Test Location and Testing Equipment for Terminal Station</i>	<i>136</i>
10.5.3	<i>Documentation</i>	<i>136</i>
10.5.4	<i>Test Equipment Maintenance Contracts</i>	<i>136</i>
10.6	CABLE JOINTING, FIBER SPLICING AND PROCEDURES	137
10.6.1	<i>General.....</i>	<i>137</i>

RSN Technical Specifications

10.6.2	<i>Delivery</i>	137
10.6.3	<i>Quantity</i>	137
10.7	SPARE PLANT	137
10.7.1	<i>General</i>	137
10.7.2	<i>Delivery</i>	137
10.7.3	<i>Storage Conditions of the Submersible Plant</i>	137
10.8	SPARE QUANTITIES	138
10.8.1	<i>Sparing Methodology</i>	138
10.8.2	<i>Terminal Station Equipment Spares</i>	138
10.8.3	<i>Spare Repeaters, Equalizers and Branching Units (If applicable)</i>	139
10.8.4	<i>Spare Cable</i>	140
10.8.5	<i>Spare Primary Nodes</i>	140
10.9	SPARES TEST PROGRAM	141
11	DOCUMENTATION	142
11.1	SCOPE	142
11.2	LANGUAGE	142
11.3	SUBMISSION AND ACCEPTANCE OF DOCUMENTATION	142
11.3.1	<i>General</i>	142
11.3.2	<i>Approval</i>	142
11.4	SUPPLY OF DOCUMENTS	143
11.5	STANDARD REQUIREMENTS	143
11.6	DRAWING STANDARDS	143
11.6.1	<i>General</i>	143
11.6.2	<i>Drawings Amendments</i>	143
11.7	HANDBOOK PRESENTATION	144
11.7.1	<i>Identification</i>	144
11.7.2	<i>History Sheet</i>	144
11.7.3	<i>Drawings</i>	144
11.8	INITIAL POST CONTRACT DOCUMENTATION	144
11.8.1	<i>Straight Line Diagram</i>	144
11.8.2	<i>Route Position List</i>	144
11.8.3	<i>Plan of Work</i>	144
11.8.4	<i>Survey and Marine Operations Schedule</i>	145
11.8.5	<i>Contractor's QA Handbook</i>	145
11.8.6	<i>Components and Materials</i>	145
11.8.7	<i>Training Courses Information</i>	145
11.8.8	<i>Documentation Master List</i>	145
11.9	PRE-MANUFACTURE DOCUMENTATION	145
11.9.1	<i>Descriptive Handbooks Contents</i>	145
11.9.2	<i>SLTE and Interconnecting Equipment Block Diagrams</i>	146
11.9.3	<i>SLTE/Interconnecting Equipment Face Layout Drawings</i>	146
11.9.4	<i>PFE Block Diagrams</i>	146
11.9.5	<i>PFE Face Layout Drawings</i>	147
11.9.6	<i>Management Terminal Equipment (MTE)</i>	147
11.9.7	<i>Network Management System Description (NMS)</i>	147
11.9.8	<i>Submersible Plant Handbook</i>	147
11.10	PRE-FACTORY TESTING DOCUMENTATION	149
11.10.1	<i>Factory Terminal Station Equipment Suite Test Handbook</i>	149
11.10.2	<i>In-station Installation and Suite Test Handbook</i>	149
11.11	PRE-INSTALLATION DOCUMENTATION	149
11.11.1	<i>Terminal Station Equipment Installation Instructions</i>	149
11.11.2	<i>Land Cable and Return Earth System Installation Instructions</i>	150
11.11.3	<i>System Loading and Laying Instructions</i>	150
11.11.4	<i>Burial Assessment Survey (BAS) Report</i>	150

RSN Technical Specifications

11.11.5	Route Clearance Report	151
11.11.6	Plow Burial Inspection/PLBO Report	152
11.11.7	Daily Reports.....	152
11.12	POST-INSTALLATION DOCUMENTATION	152
11.12.1	Interim Laying Report	152
11.12.2	Load and Laying Report.....	153
11.12.3	Assembly, Load and Laying Test Report.....	154
11.12.4	Updating of Handbooks	154
11.12.5	Acceptance Report Template.....	154
11.12.6	O&M Recommended Procedures.....	155
11.13	UPDATING OF DOCUMENTS AND REPORTS	155
12	TRAINING OF PERSONNEL.....	156
12.1	PURPOSE OF THE CHAPTER	156
12.2	SCOPE OF THE TRAINING	156
12.2.1	Type A Training.....	156
12.2.2	Type B Training.....	156
12.2.3	Type C Training	157
12.3	TRAINING QUOTATION	157
12.3.1	Type A Training.....	157
12.3.2	Type B Training.....	157
12.3.3	Type C Training	157
12.4	COURSE CONTENT	158
12.4.1	General.....	158
12.4.2	Course objectives	158
12.5	TRAINING ORGANIZATION.....	161
12.5.1	Standardized Symbols and Vocabulary.....	161
12.5.2	Language.....	161
12.5.3	Training Materials	161
12.5.4	Balanced and Coordinated Program	161
12.5.5	Progress Tests	162
13	QUALITY ASSURANCE AND FACTORY INSPECTION.....	163
13.1	QUALITY ASSURANCE REQUIREMENTS	163
13.2	CONTRACTOR'S QUALITY ASSURANCE SYSTEM	163
13.3	QUALITY ASSURANCE SPECIFICATIONS.....	166
13.3.1	Quality Assurance of Terminal Station Equipment.....	166
13.3.2	Quality Assurance of Repeater Components.....	167
13.3.3	Quality Assurance of Submersible Repeaters	167
13.3.4	Quality Assurance of Primary Node Components	167
13.3.5	Quality Assurance of Primary Node	167
13.3.6	Quality Assurance of Cable Materials Including Optical Fibers	167
13.3.7	Quality Assurance of Cable.....	168
13.3.8	Quality Assurance of Cable Joints, Terminations.....	168
13.4	RIGHT OF ACCESS FOR INSPECTION	168
13.5	RELEASE OF ITEMS FURTHER TO FACTORY TESTS AND POST-INSTALLATION TESTS ON SITE ..	169
14	CABLE ROUTE SURVEY ACTIVITIES	169
14.1	GENERAL	169
14.2	GENERAL CONDITIONS	169
14.2.1	Survey Objectives	169
14.2.2	Contractor's Responsibilities	170
14.3	SURVEY SCOPE OF WORK.....	170
14.4	SURVEY PLAN OF WORK	172

RSN Technical Specifications

14.5	ROUTE SURVEY REQUIREMENTS	172
14.5.1	Methodology.....	172
14.6	SURVEY VESSELS AND PERSONNEL	178
14.7	PURCHASER REPRESENTATION	179
14.8	NAVIGATION AND POSITIONING EQUIPMENT.....	179
14.9	ADDITIONAL EQUIPMENT	180
14.10	EQUIPMENT MAINTENANCE, OPERATION AND DOWNTIME	180
14.11	SURVEY REPORT.....	180
14.12	DELIVERY AND REVIEW / APPROVAL OF REPORTS	182
14.12.1	Provisional Survey Report	182
14.12.2	System SLD.....	183
14.12.3	Final Survey Report	183
15	LIST OF ABBREVIATIONS.....	184

1 INTRODUCTION

1.1 General

This section of the document will describe the minimum technical requirements for the procurement of the Regional Scale Nodes' (RSN) Primary Infrastructure network and the associated shore based terminal equipment. It is designed to complement the financial and contractual sections described in the first part of this document.

The Primary Infrastructure network shall have a design life of not less than 25 years. The Contractor will be responsible for all aspects of the work required to deliver the system to the Purchaser.

1.2 Definitions

A **Cable Segment** means the cable and equipment between a Cable Shore Station and a Primary Node or the cable and equipment between two Primary Nodes.

A **Cable Line** is the entire string of Cable Segments extending from a Cable Shore Station to the last Primary Node on the string.

A **Cable Shore Station** is the shore terminus of a Cable Line and contains all equipment required to operate that particular Cable Line.

A **Primary Node** is an underwater unit that receives high-voltage DC power and multi Gbps communication links from a Cable Shore Station and provides regulated low voltage power and Gbps communication to a set of "Secondary Infrastructure" science instruments.

The **Secondary Infrastructure** (not-included in this RFP) is the set of underwater science sensors, instruments, moorings and interface boxes that are powered by and communicate with the Cable Shore Stations by way of the Primary Infrastructure defined in this RFP.

Pacific City is the location of a Cable Shore Station on the coast of Oregon.

Observatory Management System (OMS) is the Purchaser's management system.

The **Ocean Ground Bed** is the Primary Infrastructure "ground anode" located at the Cable Shore Station. The return current from all Primary Nodes terminated at the Cable Shore Station will be returned to "earth" at this location.

A **Seawater Ground** is the return current ground "cathode" for a Primary Node. All Primary Nodes will have Seawater Grounds.

RSN Technical Specifications

A **Digital Line Section** (DLS) is a 10 GbE format transmission data link. A DLS is defined by an ITU-T standard and can be interfaced with any third party terminal equipment that complies with the same standard.

A **Channel** (also called a “**Wavelength**” in DWDM systems) is the optical carrier of a DLS and propagates in the optical fibers of the submarine segments.

A **SLTE** is the terminal equipment that terminates the optical fibers from the submarine segments and provides the DLS interfaces at the boundary of the System.

A **Marine Repair** is any repair required seaward of the beach manhole

1.3 Special Technical Instructions

The design of the Primary Infrastructure will be the responsibility of the Contractor. The design will be judged on its ability to provide a reliable system that meets the requirements specified in this document at a reasonable cost. Several major factors in the design are described below:

- A) The decision to use or not use Repeaters, Equalizers and Branching Units in the design will be at the discretion of the Contractor. The effects of this decision on meeting system requirements must be fully explained.
- B) The choice of which type of optical transport system to use for the Communication function will be at the discretion of the Contractor. The effects of this decision on meeting system requirements must be fully explained.
- C) The decision to use or not use connectors in the Cable Network System will be at the discretion of the Contractor. The effects of this decision on the costs, reliability and robustness of the system during the full life-cycle of 25 year operation and maintenance must be fully described.
- D) The selection of materials to be used in the different system components will be at the discretion of the Contractor. The effects of this decision on system robustness, reliability and maintenance must be fully described.
- E) The decision to use or not use connectors for the Primary Node’s Input and Expansion Ports is at the discretion of the Contractor. If the Contractor decides to use connectors on either of these ports they must be of the ROV wet-mateable type.
- F) The selection of the types of connectors to be used on the Primary Node’s Science Ports and High-Bandwidth Science Ports will be at the discretion of the

RSN Technical Specifications

Contractor but must be of the ROV wet-mateable type. The Contractor will be required to furnish the appropriate mating connectors for each Science Port and High-Bandwidth Science Port connector selected for the design.

- G) In general Contractors are encouraged to provide cost effective solutions that can still meet the power, bandwidth and availability requirements.

2 GENERAL SYSTEM DESCRIPTION

2.1 Overview

A simplified functional block diagram of the Primary Infrastructure is shown in Figure 1. The system shall initially consist of (7) seven scientific underwater terminals called Primary Nodes that are connected to a Cable Shore Station located on the Oregon coastline. The Primary Infrastructure shall connect to a Secondary Infrastructure that is not part of this RFP. This Secondary Infrastructure will consist of the sensors and interface equipment that are required to fulfill the scientific goal of the project. The Primary Infrastructure's main function shall be to provide the power and bandwidth required to operate this science equipment and to transfer all data collected by the sensors back to the Cable Shore Stations. The Secondary Infrastructure requirements shall be defined by the interfaces provided in this Technical Specification. The Primary Infrastructure system shall also include Cable Shore Station Power Feed Equipment (PFE) and the Submarine Line Termination Equipment (SLTE) required for system communications as well as the Network Management System required for system control and status monitoring. The Cable Shore Station buildings and non Primary Infrastructure facilities and equipments will be provided by the Purchaser.

A critical feature of the RSN Primary Infrastructure network is the ability for future expansion to extend the physical reach of the system and increase the number of science experiments running continuously in the system. The system shall support at least 6 Primary Nodes attached to each Cable Line. A block diagram showing the minimum required expansion locations for Primary Nodes is shown in Figure 1.

The system shall be designed to accommodate expansion at these points in the system with minimal reconfiguration of the initially installed Primary Infrastructure.

RSN Technical Specifications

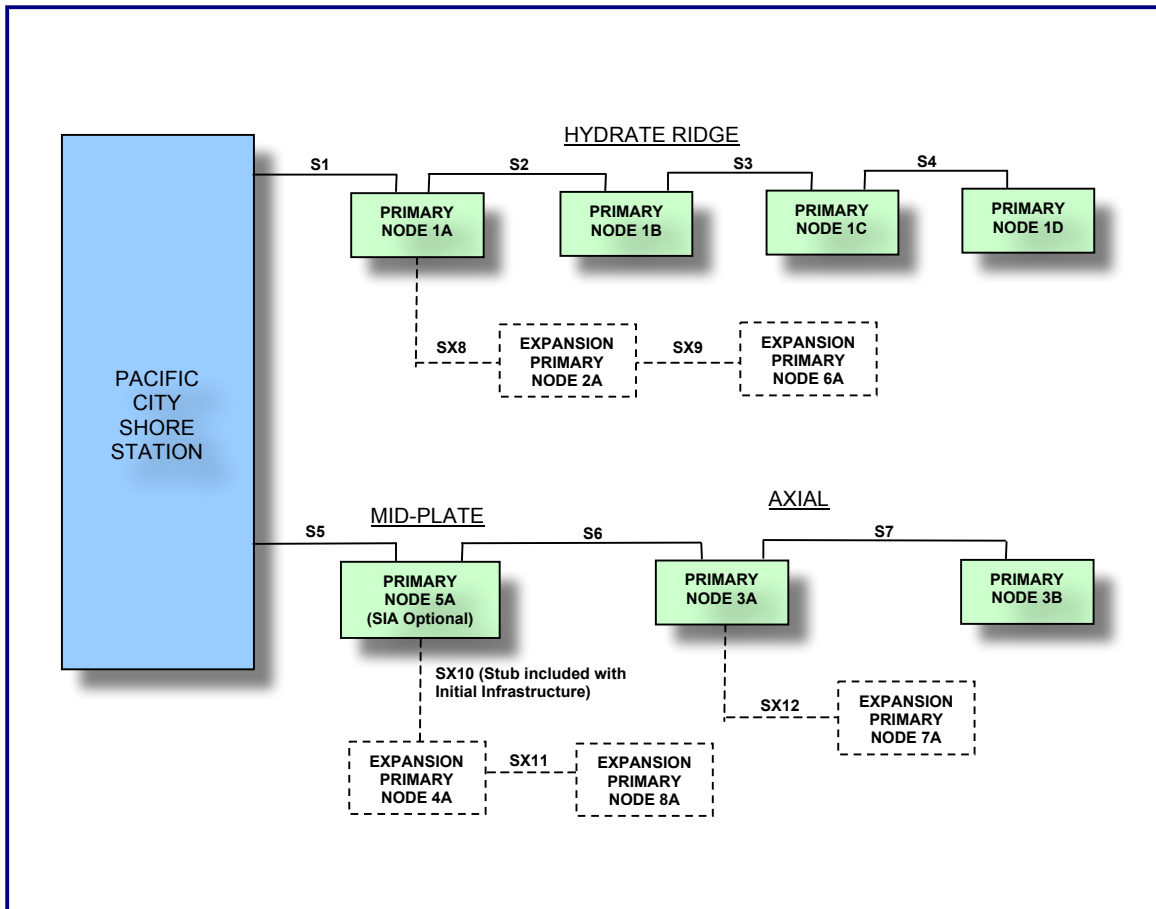

Figure 1 – Regional Scale Node Primary Infrastructure Functional Block Diagram
(Dotted lines represent possible future expansion of the RSN System)

2.2 Cable Network System

The Cable Network System shall interconnect all of the Primary Infrastructure’s components.

The Cable Network System shall consist of the (7) seven cable segments shown in Table 1. The cable lengths and Node positions are approximate at this time and will not be fully described until after the system survey has been completed. In addition Table 1 includes the approximate locations of future Expansion Primary Nodes and the cable Expansion segments required to connect them.

The Cable Network subsystem also includes the beach cables, access manholes and all complimentary equipment that the Contractor needs to implement their cable design. The decision on whether to use repeaters, equalizers, branching units, backbone connectors or other standard type items in the design will be left up to the Contractor.

RSN Technical Specifications

SEGMENT	STARTING LOCATION	ENDING LOCATION	DESCRIPTION
S1	Pacific City Cable Shore Station	Lat: 44°30'34" N Long: 125°23'53" W	Pacific City to Node 1
S2	Lat: 44°30'34" N Long: 125°23'53" W	Lat: 44°31'45" N Long: 125°09'51" W	Node 1A-1B Extension Cable
S3	Lat: 44°31'45" N Long: 125°09'51" W	Lat: 44°39'00" N Long: 124°54'00" W	Node 1B-1C Extension Cable
S4	Lat: 44°39'00" N Long: 124°54'00" W	Lat: 44°42'41" N Long: 124°30'53" W	Node 1C-1D Extension Cable
S5	Pacific City Cable Shore Station	Lat: 45°33'00" N Long: 127°45'00" W	Pacific City to Node 5A
S6	Lat: 45°33'00" N Long: 127°45'00" W	Lat: 45°51'17" N Long: 129°43'31" W	Node 5A to Node 3A
S7	Lat: 45°51'17" N Long: 129°43'31" W	Lat: 45°56'56" N Long: 129°58'50" W	Node 3A-3B Extension Cable
SX8	Lat: 44°30'34" N Long: 125°23'53" W	Lat: 43°44'13" N Long: 127°56'14" W	Future: Node 1A to Expansion Node 2A
SX9	Lat: 43°44'13" N Long: 127°56'14" W	Lat: 44°11'43" N Long: 129°18'00" W	Future: Expansion Node 2A to Expansion Node 6A
SX10	Lat: 45°3'00" N Long: 127°45'00" W	Lat: 47°00'18" N Long: 126°06'58" W	Future: Node 5A to Expansion Node 4A
SX11	Lat: 47°00'18" N Long: 126°06'58" W	Lat: 46°56'26" N Long: 124°42'11" W	Future: Expansion Node 4A to Expansion Node 8A
SX12	Lat: 45°51'17" N Long: 129°43'31" W	Lat: 44°35'59" N Long: 130°20'48" W	Future: Node 3A to Expansion Node 7A

Table 1 – RSN Primary Infrastructure Cable Segments

2.3 Primary Node General Description

The Primary Node shall be the main interface between the Wet Plant backbone cable and the Secondary Infrastructure's underwater science equipment. A Primary Node shall convert incoming high-voltage DC power to lower levels that are more suitable to powering scientific instrumentation. In a similar manner the Primary Node shall perform the basic data server function needed to handle all command timing and data communication between the secondary science infrastructure and the Cable Shore Station. The design of the Primary Node shall allow for "serial expansion" of the units to allow for extending their function beyond the first Node in a Cable Line. This extension capability is one of the major capabilities required of the system. A simplified outline diagram of a Primary Node is shown in Figure 2.

To handle the required functions, the Primary Node shall have a single Input Port and three different types of output ports. These ports shall define the basic functional requirements of the Primary Node. The internal description of the Node will be left up to the Contractor. The description of the Input Port and the Expansion Ports will be kept to a minimum with the details left up to the Contractor. Detailed specifications for the Primary Node are described in Section 5.6.

RSN Technical Specifications

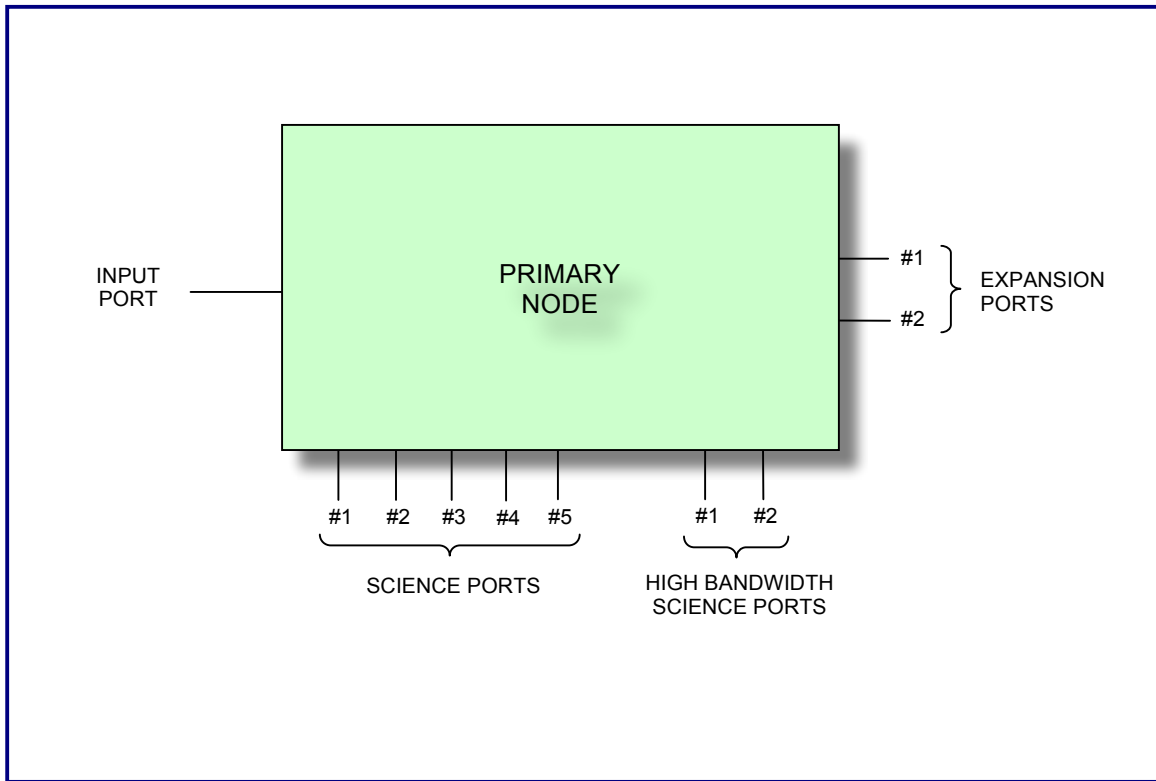

Figure 2 – Primary Node Input / Output Ports

2.4 Communication System

The Communication System includes all communication equipment between the Purchaser’s Point-of-Presence equipment in the Cable Shore Stations and each of the Primary Nodes output ports. A simplified block diagram of the system is shown in Figure 3.

The initial capability of the Primary Infrastructure shall be the ability to provide the simultaneous bidirectional communication bandwidths to each Primary Node at 10 Gbps.

The Contractor shall provide a comprehensive description of how the system can be expanded in the future with minimal reconfiguration of initial installed infrastructure to support simultaneous bidirectional communication bandwidths to additional Primary Nodes at 10 Gbps connected as shown in Figure 1.

The Communication System shall provide Ethernet Layer 2 Switch functionality internal to each Primary Node. The switch shall have at least the following management features:

- MAC Filtering
- SNMP monitoring of device and link health

RSN Technical Specifications

- Virtual Networks (VLAN) settings
- Priority settings for ports
- 802.1X network access control

A functional block diagram of the Communication System is shown in Figure 3. Each colored line represents a 10 Gbps communication channel

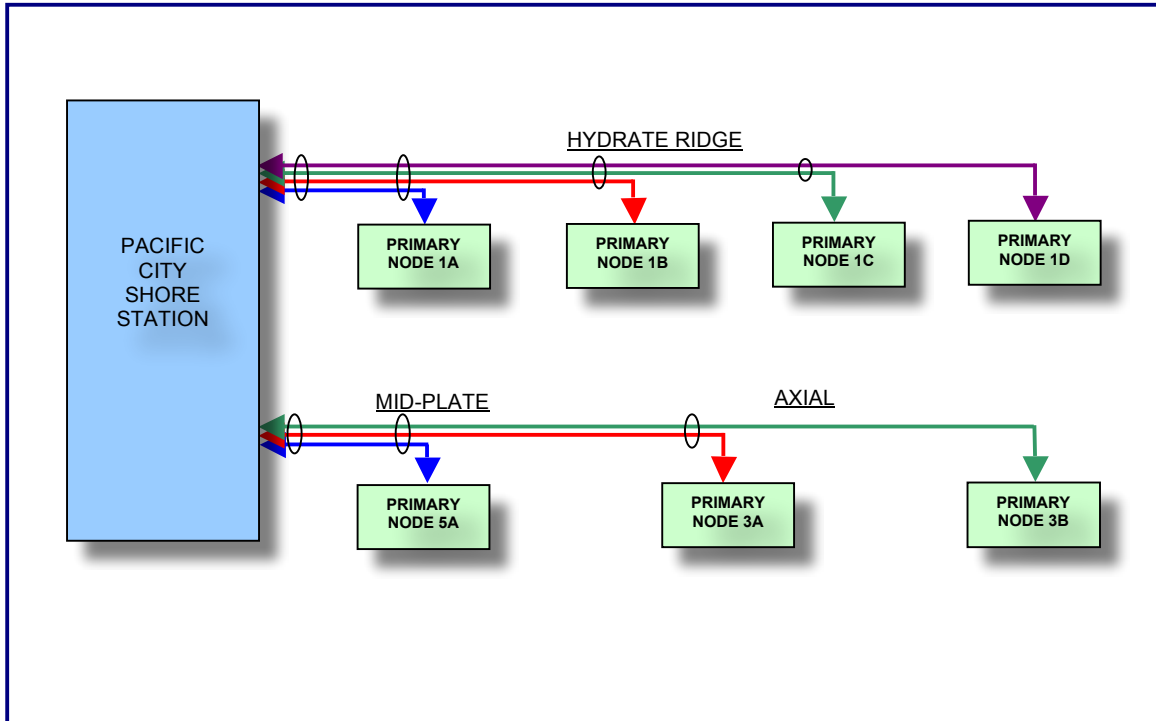

Figure 3 – Regional Scale Nodes Communication System

2.5 Power Subsystem

The Power Subsystem shall consist of all equipment necessary to provide DC power to the entire Primary Infrastructure. This equipment shall include all parts of the Power Feed Equipment, Surge Suppression Equipment, Sea Grounding Equipment, cable subsystem, repeaters, branching units and power switching and monitoring networks within the Primary Nodes.

RSN Technical Specifications

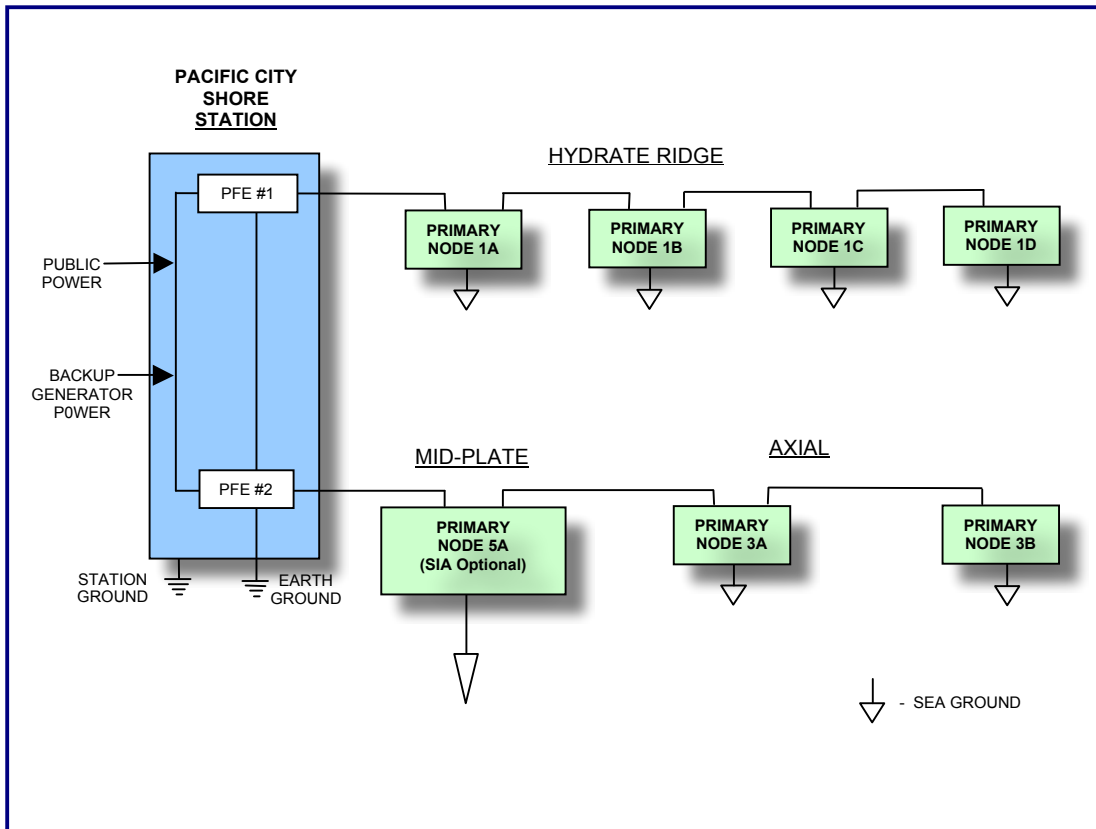

Figure 4 – Regional Scale Nodes Power System

The Power System shall provide simultaneously up to 10kW of regulated DC power to each Primary Node in the initial 7 Primary Node design. Future expansions that add additional Primary Nodes to the system may require a reduction in the amount of regulated DC power available to each Primary Node.

Of this 10kWatts of regulated DC provided by the Power Subsystem to each Primary Node, a total of at least 8kW shall be available at all times to provide regulated output power to the Science Ports and High Bandwidth Science Ports accounting for all power used in the Primary Node including Primary Node Electronics and DC/DC conversion losses.

The Power Subsystem shall allow the 8kWatts of power available to the Science Ports and High Bandwidth Science Ports in a Primary Node to be distributed among the different ports depending on their power requirements under control of the Network Management System.

The Power Subsystem shall allow any Science Port or High Bandwidth Port in a Primary Node to receive the full 8kWatts of power available for the Science Ports and High Bandwidth Ports in a Primary Node. In this case no power will be available to the other Science Ports.

RSN Technical Specifications

The Power Subsystem will provide a means of passing sufficient power through each Primary Node to supply the required 10 kWatts of power to all of the Primary Nodes in any valid configuration of Primary Nodes.

The Power Subsystem shall support at least 6 Primary Nodes attached to each cable line. Expansions to the system may require a reduction in the amount of regulated power available to each Primary Node.

The PFE's located at the Cable Shore Station shall power the sub-sea system with a DC voltage of negative polarity in reference to the Seawater Ground voltage of each Primary Node.

The Contractor shall determine the characteristics of the PFE's power generation equipment necessary to meet the system design.

The PFE's located at the Cable Shore Station shall have the ability to shut down power to an individual cable line without affecting the power supplied to any other cable lines powered from the Cable Shore Station.

The PFE's shall be powered by the Cable Shore Station's three-phase 440/480 volt AC supply provided by either the local public utility or the Cable Shore Station's backup generators.

In the event of a disruption of their incoming ac power source, the PFE's shall automatically shut down after their internal batteries discharge.

The PFE's shall require a manual restart after the disruption of their incoming AC power source that is longer than the internal battery holdup time.

The Purchaser shall be responsible for providing sufficient backup generators and public utility power to handle all of the Cable Shore Station requirements.

The Power Subsystem shall provide enough PFE Capacity to meet the maximum power requirements of the Primary Nodes for each cable line as shown in Figure 4. The Power Requirements of the PFE Equipment to meet this requirement shall take into account additional power transmission losses due to cable resistance and any intermediate electronics system loads.

The Contractor shall provide a comprehensive description of how the system can be expanded in the future with minimal reconfiguration of initial installed infrastructure to support maximum power to additional Primary Nodes connected as show in Figure 1.

RSN Technical Specifications

The Power Subsystem shall allow future additional Primary Nodes added to the system through Primary Node Expansion Ports to share available power on a cable line, without hardware modifications to the Cable Shore Station Equipment.

2.6 Management Subsystem

The Management Subsystem shall include of all the equipment that is used to monitor, control and alarm the System.

The Management Subsystem shall include the data communication network (DCN) that allows communication between the various pieces of equipment, with the NMS and the outside world.

DCN redundancy features shall be designed to allow OA&M activities to continue in case of cable break or other communication failure inside or outside the System.

A “System Internal DCN” shall be provided using the System data paths to support all Management activities and to provide a User DCN which bit rate should be at least 2Mbps.

Interfaces to the Management System shall be provided to Purchaser for connectivity to their WAN

Interfaces to the Management Subsystem shall be provided for Back Door/redundant internet access.

The Management Subsystem includes:

- Element Manager Systems (EMS) that monitor, control and alarm individual Network Elements (NEs) such as the SLTEs, PFEs and Primary Nodes
- All software running on all equipment
- All applications necessary to perform the OA&M functions, including, but not limited to, the GUI and third party software that may be used by the Supplier such as Graphical Packages, Data Bases etc...
- The Interface to the Purchaser’s Observatory Management System.

A functional block diagram of the RSN Management Subsystem is shown in Figure 5.

The Management System shall be designed to allow future Primary Nodes to be added to the system with minimal configuration.

The Management System shall be designed with sufficient capacity to allow future Primary Nodes to be added to the system with no loss of control and monitoring functionality.

RSN Technical Specifications

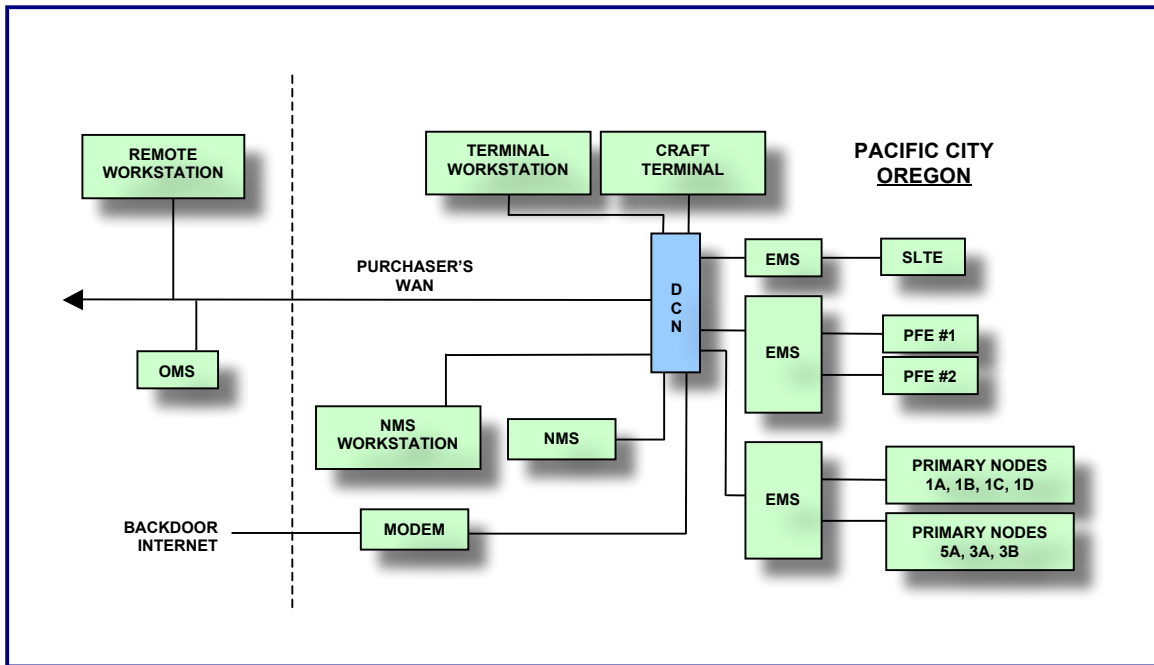

Figure 5 – RSN Management Subsystem

2.7 Work Scope

2.7.1 Work Inclusions

The work shall include everything specified in these Technical Specifications, but not limited to:

- Engineering, planning, management and coordination of the implementation of the System
- Marine Survey Route as specified in the Technical Specifications
- Burial Assessment Survey (BAS)
- Undersea Cable Route Clearance and Pre-lay grapnel runs as specified in the Technical Specifications
- Design, manufacture and testing of all elements of the System, including spares
- Freight and delivery of all elements of the System, including spares
- Provision of all materials, test equipment, labor and services, cable laying vessels, support crafts, submersible vehicles, cable plows and as specified in the Technical Specifications
- Inspection of the buried Marine cable areas as specified in the Technical Specifications
- Remedial post-lay burial as specified in the Technical Specifications and cable crossings as specified in the Technical Specifications
- Installation and testing of all the elements of the system, including terminal equipment, land sections, submarine segments and ocean grounds as specified in the Technical Specifications.

RSN Technical Specifications

- Installation and testing of the Communication Subsystem
- Installation of shore end cable protection as specified in the Technical Specifications
- Overall testing and commissioning of the System
- Provision of all documentation
- Provision of training in the operation and maintenance of the System
- Obtaining permits for construction, installation and related marine operations identified in Clause 26 of the System Supply Contract

2.7.2 Work Exclusions

The work to be carried out by the Contractor shall exclude the following (also identified in Clause 47 of the System Supply Contract, supplied here for reference only):

- Cable Station
- Beach Man Hole
- Conduit from Beach Man Hole to Cable Station, including pull boxes
- Primary and backup AC power and associated hardware and cables
- Station alarms system
- Station AC ground system
- System demarcation points (Patch panels, Breaker panels etc.)
- Heating, ventilation, air conditioning (HVAC)
- PFE Water Chiller
- Firewall and network security

3 General Technical Requirements

3.1 General Transmission Requirements

3.1.1 General Margin Requirements

When operating within its designed range of conditions, without equipment failure and not perturbed by outside aggressions, transmission BER is expected to be no more than 10^{-13} at all time. It is expected that transmission noise and other impairments are mitigated in such a way all errors are corrected. The margin between the worst case operating conditions and the thresholds at which transmission becomes degraded shall be, when measured in terms of db Q (20 log scale):

- a) Start of Life: 2 dB
- b) End-of Life: 1 dB

This shall be true for all channels in all segments

3.2 Compliance to Standards

3.2.1 Standards

To the greatest extent reasonably practical, all Network Infrastructure shall be consistent with the applicable sections of the national and international standards.

3.2.2 Environmental Conditions for Submarine Equipment

The Submarine equipment shall withstand the environmental conditions related to manufacturing constraints, loading and laying constraints, sea temperature and seabed environment, in such a way the design life is reached or surpassed.

Submarine Equipment shall meet all requirements installed, maintained and operated at water depths up to 3500 meters.

The Submarine Equipment shall be capable of operating at power sufficient for testing and installation over an operating temperature range of 0 to +35 degrees Celsius.

The Submarine Equipment shall be capable of operating at full power over an operating temperature range of 0 to +8 degrees Celsius for the lifetime of the system.

3.2.3 Local Standards

All equipment shall comply with the standards in effect in the United States and in the state of Oregon.

RSN Technical Specifications

3.2.4 Safety Overview

3.2.4.1 Safety Plan

The Contractor shall develop an overall Safety Plan for the development, installation and testing of the Primary Infrastructure. The Safety Plan shall be a deliverable item.

3.2.4.2 Optical Safety

Equipment producing optical radiation must comply with IEC 60 825 “Safety of laser products, equipment classification requirements and users guide”. For the submarine equipment, the Contractor must indicate the Laser Class and safety measures related to handling and repair procedures.

3.2.4.3 High Voltage Safety

The Contractor shall have a written standard for high-voltage safety practices. All onshore equipment that will require maintenance and servicing shall comply with the safety standards listed in IEEE Standard 510-1983, “IEEE Recommended Practices for Safety in High-Voltage and High-Power Testing – Description”. For the submarine equipment, the Contractor must indicate the safety measures related to handling and repair procedures, including procedures related to systems with branching units if applicable.

3.2.4.4 Grounding Practices

All terminal equipment must be grounded in accordance with the grounding practices spelled out in the current version of the National Electrical Code of the United States and any additions or upgrades listed in the corresponding electrical code of the location where the work is situated.

3.2.4.5 Protection against Lightning and other electrical perturbations

The Contractor shall have a written document that describes how the Terminal Equipment and submersible plant are protected against natural electromagnetic events such as indirect lightning strikes, magnetic storms, etc., or any power surge due to a cable fault anywhere in the System.

The Contractor shall detail the consequences of such surges on the internal units of the repeaters, branching units and equalizers, and particularly, where appropriate, on the power switching units and internal dielectric insulation.

3.2.4.6 Shock and Vibrations

The equipment shall be designed to withstand shock and vibrations as described in the individual equipment requirements. Those shall be consistent with the expected stress to be applied to the equipment during its Life, including stresses due to transportation and handling during installation and possibly recovery and repair.

3.3 Reliability and Availability

3.3.1 Primary Infrastructure Reliability Requirement

The Reliability of the Primary Infrastructure shall be such that there is at least a 95% confidence that no more than 2 Marine Repairs requiring a cable ship of sub-sea Primary Infrastructure components are required for each Cable Line over the system design life excluding failures due to external aggression.

The Supplier shall provide proposed repair methodologies and estimated costs for all types of anticipated Primary Infrastructure repairs at PDR and updated at CDR.

The Supplier shall provide details of any required planned maintenance and cost to achieve the overall reliability requirement at PDR and updated at CDR.

3.3.2 Overall Reliability Calculation

The Contractor shall provide the overall reliability calculation that demonstrates compliance to the requirements using the individual reliability figures.

3.3.3 Calculation Methodology

The Contractor shall describe the reliability calculation model.

3.3.4 Failure Rate Analysis for Subsystem Components

The Contractor shall provide the FIT rates for subsystem components.

3.3.5 Primary Infrastructure Availability

The Availability of a Primary Node Expansion Port, Science Port or High Bandwidth Science Port is defined to be the percentage of time that the Primary Infrastructure is able to deliver the required Power, Bandwidth, Timing and Control to that port from the inputs of the SLTE and PFE in the Shore Station.

There shall be at least a 95% confidence that all Primary Node Expansion, Science and High Bandwidth Ports have an Availability of at least 99.5% exclusive of the time needed to make Marine Repairs to sub-sea Primary Infrastructure components due to external aggression.

3.4 Components Traceability

The Contractor shall describe the method by which critical components and sub-systems will be traceable in case a Failure Mode Analysis is required.

The Contractor shall indicate which critical components and sub-systems are serialized.

RSN Technical Specifications

3.5 Transmission Path Identification

The Contractor shall describe the method by which the transmission path can be easily identified during repairs.

In particular, the Contractor shall try to implement color continuity throughout the system.

If it is not possible, detailed fiber color maps must be provided. Color transitions through various cable types, fiber types, repeaters and branching units must be documented.

3.6 Equipment Alarms

3.6.1 List of Alarms

The Contractor shall provide a preliminary list of alarms and related thresholds.

3.6.2 Cable Station Alarms

Terminal equipment shall have interfaces with Cable Station Alarms

3.6.3 External Interfaces for Alarms

System must be capable of passing all alarms through the System to System Interface to the Purchaser's Observatory Management System..

External interface for alarms is based on TCP/IP CORBA with SNMP protocol or other protocols as agreed to by the Purchaser and Contractor.

3.6.4 Housekeeping Alarms

The Contractor shall describe its Terminal Equipment capabilities in terms of Housekeeping alarms: number of interfaces, interfaces types.

3.7 Management Equipment General Requirements

3.7.1 General

The Contractor shall describe the complete suite of management equipment that allows management of all the sub-systems defined in that document, including all transmission equipment and powering equipment.

3.7.2 Integration

It is anticipated that a high degree of integration of the management sub-systems can be achieved in such a way all alarms and performance parameters of the entire system are accessible through a single console with the exception of the Line Monitoring Equipment which may use its own terminal. The console may use separate display screens and preexisting monitoring applications to display alarms and other performance parameters.

RSN Technical Specifications

3.7.3 In-service Capabilities

The Management equipment shall be able to provide accurate in-service information regarding the state of the undersea system.

The Contractor shall indicate the Fault Location accuracy (in meters) that will be provided by the submarine sub-system monitoring equipment, both in-service and out-of-service.

The Contractor shall indicate the sensitivity of the Management sub-system in terms of detection of degraded equipment, such as detection of high optical loss in the optical path, detection of failed or degraded pump lasers in the optical amplification units, detection of abnormal voltage and/or currents in the power feed equipment.

The detection of anomalies shall be highly automated. It shall be possible to continuously monitor critical parameters, to schedule system scans and collect results. Alarms with programmable severity shall be triggered at the threshold crossing.

3.7.4 Out-of-service Capabilities

The Contractor shall indicate the improvement in fault location accuracy when the measurement is done out-of-service.

3.7.5 Interfaces with Transmission/PFE Equipment

The Contractor shall describe the interfaces between the Management sub-system and the Transmission and PFE equipment. High speed/standard interfaces are expected. Historical PM and alarm data are stored in circular queues in the equipment. Provisioning information is stored in the equipment. Data backup procedures are provided.

The management interfaces shall maintain the electrical insulation between the equipment. There shall be no ground connectivity between equipment on the management interface

3.7.6 Impact on Transmission Performance

Failure of management interfaces shall typically have no impact on the transmission performance. Automatic adjustments that optimize channel performance require the management interface to operate.

3.7.7 Access Diversity

This section has been intentionally left blank.

3.7.8 Data Storage

The Management sub-system shall include data storage with the following characteristics:

- At least 30 days of “normal” system activity and performance log can be stored

RSN Technical Specifications

- It is redundant e.g. at least 2 data storage sub-systems operate in parallel
- It can be easily backed up
- It is fast e.g. retrieving any data within the 30 days period does not take more than seconds
- The cost per Gbit is low, comparable with usual data storage IT costs
- It is secure. Access is strictly controlled.
- Performance data is kept resident on the server for one year, and is automatically archived before deletion.

3.7.9 Data Safekeeping and Retrieval

The Management sub-system shall include an “Archiving” system with the following characteristics:

- It is scalable in accordance with the expected data to be produced during the life of the system
- It is secure. Access is strictly controlled and data cannot be deleted

3.7.10 Time Stamping

- Accurate and systematic Time stamping is a very important function of the management system
- It must be possible to align all equipment time stamps to a Time server locked on UTC
- It must be possible to record all events in UTC time independently from the local time zone
- The Time stamp must be as accurate as practical, indicating the true time of the event as quickly as possible
- The Time stamping sub-system must be able to use at least 2 time servers for redundancy purpose
- The management sub-system must clearly indicate the Time Zone in use on each page of events
- There may be an option to display both the UTC time stamp and Local time stamp. In that case, each time stamp must be clearly identified

3.8 General Powering Requirements

3.8.1 DC Voltage

The Contractor shall indicate the nominal DC voltage for each cable segment of the Primary Infrastructure system.

3.8.2 High Voltage Rating

The Contractor shall indicate the maximum high voltage rating of all components of the Primary Infrastructure equipment.

3.8.3 Modes of Operation (I/V Functions)

The Contractor shall describe all the DC Power Feed modes of operations, including:

RSN Technical Specifications

- I/V curves during normal ramp up and ramp down
- I/V curves across the entire range of operation, including the operating conditions during faults, open circuit and short circuit

3.8.4 Surge Protection Features (including branching units if applicable)

The Contractor shall describe the Surge Protection Features, and in particular the protection against shunt faults at the maximum rated voltage.

3.9 Safety Features

The Contractor shall describe the safety features related to all Primary Infrastructure equipment and in particular to the protection of personnel against accidental exposure to high voltage.

3.10 Maintenance Features (including features to facilitate cable fault repairs)

The Contractor shall describe the maintenance features related to all equipment included in the system.

3.11 Naming, Labels and Numbering

All the equipment provided should be labeled with labels that are:

- Consistent with the documentation and drawings
- Consistent with the Management sub-system names, in particular on the GUI
- Unique (e.g. one label cannot apply to 2 different pieces)

The Naming, Labeling and Numbering conventions shall be submitted to Purchaser for their review and approval.

3.12 Colors

The Contractor shall indicate the equipment colors.

3.13 Test Equipment

3.13.1 Transmission Test Equipment

The Contractor shall recommend a list of transmission test equipment. Purchasing of that equipment is optional.

3.13.2 Fault Localization Test Equipment

The Contractor shall recommend a list of Fault Localization test equipment. Purchasing of that equipment is optional.

RSN Technical Specifications

3.13.3 Power Test Equipment

The Contractor shall recommend a list of test equipment for the troubleshooting of the High Voltage DC sub-system. Purchasing of that equipment is optional.

3.14 Tools

The Contractor shall recommend a list of tools for the maintenance and troubleshooting of the system. Purchasing of that equipment is optional.

3.15 Spares

The Contractor shall provide a complete List of Spares that is consistent with the overall availability objective.

The List of Spares shall be kept separate from the base list of equipment that comprises the system. They must be priced separately. Spares shall be made available to support installation and commissioning activities.

Spare storage equipment shall be provided with the spares.

Spares shall be submitted to the same level of testing than the regular items and be of the same quality.

4 Transmission Performance

4.1 End-to-end Performance

4.1.1 Power/Impairment Budget Template

For each digital line segment, the Contractor shall provide a preliminary Power/Impairment Budget based on dB Q (20log), on a template that shall include (but not limited to):

- Start of Life (SOL) and End-of-Life (EOL) values
- Nominal Q based on Noise (OSNR)
- Q degradation due to non-linearities (Contractor to specify)
- Q degradation due to wavelength worst case variations
- Q degradation due to polarization effects
- Q degradation due to Supervisory activity
- Repair allocation
- Aging allocation
- Pump failure(s) allocation (consistent with pump reliability figures)
- Other impairments

The Contractor shall provide the worst case SOL and EOL BER related to worst-case impairments and allocations.

An updated optical analysis shall be provided after Test Bed Technology Demonstration and again after system testing of the actual manufactured cable line at the cable factory.

4.1.2 BER Objective

When operating within its designed range of conditions, without equipment failure and not perturbed by outside aggressions, transmission is expected to meet the BER objective of $<1.0E-13$.

4.1.3 Transmission Capacity

The System shall be capable of transmitting at least 10GbE data bandwidth from the terrestrial end of the system to each of the Primary Nodes.

4.1.4 Minimum Optical Loading (if applicable)

The Contractor shall indicate if a minimum optical loading is required to operate the system. If yes, such loading shall be described in details, together with the equipment that generates it.

4.2 Optical Power Budget

4.2.1 Start-of-Life Q-Margin

The expected SOL Q-margin shall be at least 2 dB.

4.2.2 End-of-Life Margin

The expected EOL Q-margin shall be at least 1 dB.

4.2.3 Repair Margin

The Contractor shall indicate the assumptions made to determine the repair margin:

- Number of additional splices
- Loss per splice
- Added cable length
- Cable loss
- Dispersion management error

The Contractor shall provide simulation results to support the repair margin number.

4.2.4 Margin for Monitoring Signals

The Contractor shall provide experimental results to support the monitoring signal margin number.

4.2.5 Other Margins

The Contractor shall describe the other margin numbers, in particular in relation with laser pump failures in the submerged repeaters (if repeaters are used in the system design).

The Contractor shall indicate the number of laser pump failures in consecutive repeaters (if repeaters are used in the system design) that can be tolerated before necessitating a cable ship repair.

In addition, statistical analysis of randomly located laser pump failures shall also demonstrate compliance with the overall reliability requirements.

4.3 Dispersion Compensation Strategy

The Contractor shall describe the overall Chromatic Dispersion (CD) compensation strategy using the cable as dispersion compensation medium.

The Contractor shall provide a generic CD map, indicating the periodicity of the map and the objective for end-to-end residual CD.

The Contractor shall present nominal CD versus wavelength characteristics and CD versus sea temperature variations characteristics.

RSN Technical Specifications

4.4 System Transmission Interfaces

The Contractor shall describe the transmission interface selected for the system. Where COTS items are supplied, the Contractor shall provide available vendor data sheets in lieu of testing the requirements below. Where customized designs are developed uniquely for the RSN project the Contractor shall supply test data to satisfy the requirements below.

4.4.1 Optical Power levels

The optical power levels shall comply with the relevant ITU and/or ANSI standards for the optical interface types proposed.

4.4.2 Optical Return Loss

The optical return loss levels shall comply with the relevant ITU and/or ANSI standards for optical connection points.

4.4.3 Optical Connectors

All optical connector types in use in the System shall be specified by the Contractor

- It is the preference of Purchaser to have as few types of optical connectors in the System as is possible
- The Contractor shall specify and supply an adequate amount of optical connector cleaning and inspection kits. Each Cable Shore Station shall be equipped with these items

4.4.4 Input Wavelength Range

The input wavelength range shall comply with the relevant standard.

4.5 Tributary Independence

Failure of one 10G channel shall have no effect on the remaining channels.

4.6 Timing and Synchronization

4.6.1 Timing Modes

The Contractor shall describe the Timing Modes of its Terminal Equipment.

4.6.2 Timing Source Switching (if applicable)

If the Contractor equipment is capable of multiple Timing Sources, the Contractor shall describe the switching between timing sources.

RSN Technical Specifications

4.6.3 Effect of Timing Source Switching on Transmission Performance

Timing Source switching is expected to be hitless e.g. with no impact on traffic.

5 Submarine Equipment

5.1 Submarine Optical Amplifiers (“Repeaters”)

The primary infrastructure submarine optical amplifiers shall be an adaptation of a proven design and demonstrated for use on fiber optic transoceanic undersea cable systems for the 25 year system design life. All adaptations of the proven design or selection of other submarine optical amplifiers shall require compliance demonstration with the applicable performance requirements of this specification, as mutually agreed by the Purchaser and Supplier at SRR.

5.1.1 Detailed Description

The Contractor shall provide detailed information, at Critical Design Review (CDR), on the:

- a) Optical characteristics of the repeater, including a block schematic, nominal input and output levels, Noise Figure, gain versus wavelength characteristics, amplifier management methodology, and any performance impact resulting from a failure of a redundant pump laser
- b) Electrical characteristics, including power dissipation, current versus voltage characteristics, surge protection capabilities, low frequency current transfer characteristics (for fault location), capacitance
- c) Mechanical characteristics, including dimensions, weight and strength, thermal resistance
- d) Thermal characteristics

5.1.2 Repeater Types

The Contractor shall indicate how many types of repeater will need to be provided for this project.

Any variation of parameters such as gain curves, temperature ratings, etc. must be identified as a different repeater type.

If different repeater types are used, the Contractor must clearly specify which repeater can be used in which segment.

5.1.3 Performance History or Technology Demonstration

If the Contractor proposes a Repeater that is a proven design, it shall provide the Performance History, such as number of units in service, length of service, number of failures, etc.

If the Contractor proposes a Repeater which is a minor variation of the standard design, the history of similar Repeaters and details of the modification shall be provided at PDR and no Technology Demonstration shall be required.

RSN Technical Specifications

If the Contractor proposes a Repeater that is under development, or containing significant new developments with respect to a proven design, it shall organize a Technology Demonstration to explain the new features of the design, its advantages, capabilities, and the risks associated with it.

5.1.4 Mechanical Requirements

5.1.4.1 Repeater Size

The size of the repeater shall be such that it can be handled by cable ship equipment without the need for modification. Particularly no modification shall be necessary that would prevent the cable ship from working on existing submarine cables. In addition it is required that when the repeater is jointed to the cable it can be passed around a cable drum of 3m diameter.

5.1.4.2 Laying and Recovery

The tensile strength of the termination shall meet the cable tensile strength requirements of this Specification.

5.1.4.3 Repeater Handling

The repeater shall be capable of being laid, buried, recovered re-laid and re-buried without impairment of the performance of the cable, repeater or coupler.

5.1.4.4 Housing Strength

A break in the cable termination shall not damage the housing and internal units. The tensile strength of the housing between cable anchorage points shall be at least ten percent (10%) greater than the ultimate tensile strength of any cable to which it may be connected.

The characteristics of the Repeater and its couplers shall not be impaired after a housing has been held in suspension in cable catenaries from the cable ship bow or stern sheaves to cable laying on the sea bed, for any period needed to make three (3) full cable joints, in the most adverse cable ship conditions. The depth of water in which the cable ship is deemed to be operating is that appropriate to the type of cable in the catenaries.

5.1.4.5 Dismantling

The Repeater shall be constructed such that it shall be possible to dismantle it to carry out repairs to internal units and then reassemble it in the Contractor factory environment or similar, within the original housing.

5.1.4.6 External Finish

The finish of those surfaces of the housing which will be in contact with sea water when the repeater is in service, excluding any deliberate sacrificial anode, shall be such that it will not suffer any deleterious effects from chemical, electrolytic or galvanic corrosion due to the presence of sea water and/or other metals used in the construction of the associated submersible cable such that the performance of the repeater could be impaired over its twenty five (25) year Design Life.

RSN Technical Specifications

Any material or surface finish used in the construction elements to be enclosed within the housing shall not produce any hazardous substances or react with any other material within the housing under normal operating conditions such that the performance of the repeater may be impaired. Any material used in the manufacture processes of the components to be enclosed within the repeater housing, e.g. solvents, adhesives, fluxes, shall not produce any hazardous substances or in any other way affect any component within the repeater such that the performance of the repeater could be impaired.

5.1.4.7 Hydrogen Generation/Ingress

The housing shall be such that after twenty five (25) years, the internal level of humidity and the partial Pressure of hydrogen will not impair the performance or reliability of the repeater such that the requirements of the Specification cannot be met.

The Contractor shall provide supporting information to satisfy Purchaser in this regard, namely in what concerns the protection provided to the erbium doped fibers in the optical amplifiers.

5.1.4.8 Temperature Ranges

The repeaters shall be capable of being operated over an ambient water temperature range of 0°C to + 30°C during the System Design Life while meeting the overall System performance requirements.

They shall also be capable of being transported in a temperature range of -20°C to +40°C and long-term storage in the temperature range of 0°C to +35°C without any effect on the System Design Life requirements.

The design shall take into account the possibility that the housing may self bury, be buried or be "jetted in".

Repeaters must be able to be operated on board a cable ship during laying and repair operations without affecting their twenty five (25) year Design Life. The Contractor shall be responsible for the conditions applied to repeaters during laying.

The Contractor shall provide the conditions to be applied during laying and repair operations.

The Contractor shall indicate the power consumption of the repeater as well as the technique adopted to favor thermal dissipation of the electronic units. It also shall provide the expected mean temperature rise of the internal components relative to the temperature of the water.

5.1.4.9 Shock, Vibration and Acceleration

The Repeater shall withstand the shock, vibration and acceleration associated with transportation, handling, laying, burial, recovery and repair operations.

RSN Technical Specifications

The Contractor shall provide the standards and/or parameters used for testing,

5.1.4.10 Compatibility with Other Contractor Cables

This section has been intentionally left blank.

5.1.4.11 Shipping, Storage and Handling

The Contractor shall specify all the environmental conditions to be maintained during shipping, storage and handling.

The Contractor shall make sure that these conditions are monitored and met when shipping, storing and handling the repeaters for this project.

5.1.5 Optical Requirements

5.1.5.1 Fiber Pair Independence

This section has been intentionally left blank.

5.1.5.2 Optical Performance

The performance of individual optical amplifiers shall be commensurate with meeting the overall System performance. The Contractor shall provide the detailed description of the optical amplifiers and repeaters, and detail how the overall repeater performance over the operating temperature range will be maintained.

System design shall incorporate reasonable protection from environmental conditions such that performance shall continue to be met under most environmental conditions, including any transient reduction of power feeding current to a repeater (or repeaters) arising from lightning strike anywhere along or adjacent to the cable route including land sections, except for extraordinary circumstances.

The Optical performance characteristics versus temperature shall be provided by the Contractor, including, but not limited to, and for each type of repeater:

- Gain curve characteristics (output optical power versus input optical power; small signal gain; saturation data)
- Gain curve versus wavelength
- Noise Figure characteristics

5.1.5.3 Optical Amplifier Redundancy

The reliability of each optical amplifier shall be such that the overall reliability requirement of the system is satisfied. This may require having redundant pumping. When a pump laser becomes degraded or fails, the redundancy architecture shall enable the remaining redundant pump to automatically provide adequate gain characteristics to satisfy the overall transmission performance criteria. The degraded or failed nature of a single pump laser shall be detectable by the management sub-system. The Contractor shall indicate how many single pump failures in one optical path can be tolerated before

RSN Technical Specifications

the failure of the transmission path. This parameter shall be consistent with the overall reliability number of the system.

The Contractor shall present the structure of this redundancy.

5.1.5.4 Power Feeding

The Contractor shall describe the power-feeding unit of each type of repeater and indicate the potential differences existing between the various parts of the repeater and show how the necessary dielectric insulation is maintained during the System Design Life.

5.1.5.5 Polarity

The Contractor shall indicate if options exist for the Polarity of the Repeater.

5.1.5.6 Surge Protection

The System design shall ensure that the repeater is protected in the event of lightning strike at or adjacent to any terminal or any power surge which may result from a cable fault or Branching Unit DC path switching anywhere on the System when the PFE is feeding its maximum output.

The Contractor shall state what kind of protection the System affords from surges induced by electro-magnetic pulses.

5.1.6 Management Requirements

5.1.6.1 Supervisory and Maintenance Functions

The repeater supervisory and control circuits will provide the supervisory and maintenance information from the submersible plant elements. The supervisory method shall be able to detect a fault or degradation within a repeater.

The Contractor shall provide detailed information on the supervisory method clearly showing its working principles.

5.1.6.2 Control Features

The Contractor shall provide a list of the Controlled parameters accessible System the supervisory system, the effect of these controls and the ranges of these controls. The controlled parameters may include:

- Laser Bias Current
- Optical gain
- Other

5.1.6.3 In-service Upgrades

In particular, the Contractor shall clearly indicate if changes are required to the repeater parameters to accommodate traffic growth. If it is the case, procedures must be provided that describe the method to add or remove wavelengths to a traffic carrying fiber. The procedure must be “in-service” and without impact on existing traffic.

RSN Technical Specifications

5.1.6.4 Monitoring Features

Undersea fiber and repeaters are monitored with high-loss optical loopbacks and COTDR function as provided by the Line Monitoring Equipment as further described in Part 6.

5.1.7 Reliability

The reliability of each optical amplifier shall be such that the overall submerged plant reliability is met.

The Contractor shall present the reliability calculation for the Repeater starting from a separate reliability budget of each component type at PDR.

5.1.8 Qualification Data

The Contractor shall indicate the development status of the repeater and its qualification programs at PDR. The qualification program shall be made available to Purchaser who will have full access to the qualification results at CDR.

5.1.9 Fault localization

The Repeater shall be designed to meet the fault localization requirements specified in Chapter 10.

5.1.10 Identification of Repeater Housing

Each repeater housing shall bear the submarine cable supplier's identification number and serial number and/or letter for the housing concerned. For example, such identifications shall be readily visible on housing, normal color markings on internal surfaces shall be black or white selected to provide the better contrast. If the repeater is polarized it shall be permanently marked with an indication of the repeater polarity. Each side of the repeater (e.g. "A" or "B") shall be permanently marked.

5.1.11 Marking Quality

The method of marking and the size of characters used shall ensure that they are durable and legible throughout the Design Life of the System. In addition the application of the marking shall not leave any residue that could produce any hazardous substance or in any way affect any component within the repeater housing such that the performance of the repeater could be impaired.

5.1.12 Traceability

At any stage in the manufacture or subsequent history of a repeater, it shall be possible for the Contractor to determine the source, batch number, date of manufacture of any critical component or sub-assembly, within a repeater without recourse to dismantling it.

RSN Technical Specifications

5.1.13 Failure Modes

The Contractor shall indicate the failure modes characteristics such as:

- Zener failure mode
- Pump laser failure modes
- Monitoring system failure mode

5.1.14 Spares

The characteristics of the spare repeaters must be such that they can be used to replace any repeater.

5.1.14.1 Tails of spare Repeaters

Standard repeater tails, optical connection and packing employed by the submarine cable supplier will be provided. To the greatest extent reasonably possible, spare repeaters shall be equipped with 30-meter Single Armor (SA) tails. The ends of the cable tails shall be fitted with a 'test end' providing optical connectors and power connector to facilitate repeaters being tested periodically in a Purchaser depot. The spare repeaters will be packaged for transport and storage.

5.2 Submarine Equalizers (If Required)

This section has been intentionally left blank.

5.3 Submarine Cable Plant

5.3.1 Definition of the System SLD

The System SLD is a linear diagram of the System showing the following:

- a) The lengths and types of the land and submersible cables including any type of special cable and the slack assignment necessary to ensure the best possible positioning of the submerged plant, taking into account:
 - i) The sea bed profile
 - ii) The laying and burial procedures
 - iii) The cable types
 - iv) The repair techniques
- b) The length of each repeater, equalizer, Primary Node and BU section according to the System power budget and the repair allowances

RSN Technical Specifications

- c) The number and position of repeaters, equalizers, Primary Node and BUs
- d) Length and position of special types of cable, if any
- e) The water depth of the cable transitions, repeaters, equalizers, Primary Node and BU's
- f) The installation splices and the direction of the laying operation(s)
- g) Factory splices
- h) The identifying numbers of all repeaters, equalizers, Primary Node, splices and BUs

The Contractor shall include in their Response a Basic System SLD that includes a table summarizing the cable quantities, including spares and land cable. Following the final route survey results the SLD's will be amended by mutual agreement between Purchaser and the Contractor.

The content of the SLD shall be provided in the Contractor's format.

5.3.2 Basic System SLD

Subject to a review of the survey results, the general requirements for the types of cables in relation to the water depth are given in the following table:

Depth in meters	Cable Types
0 to 100	DA/RA
100 to 700	SA
700 to 1500	LWA
1500 to 2500	LWP
more than 2500	LW

The LWA cable shall be generally used in all the areas where cable burial is required; SA, DA or RA cables shall be recommended where burial results are doubtful.

The Contractor shall provide a tool for tracking CD over the life of the System, based on repair information.

5.3.3 Dispersion Management

Cable types incorporate dispersion management elements. The SLD must show, for each cable type, the armoring type AND the dispersion/embedded fiber type.

Each cable type in terms of armor may contain each fiber type. For example, if 5 types of armoring are used and 3 types of fiber are used, there are a total of 15 combinations.

The SLD must reflect the exact composition of each segment in both armoring type and fiber type.

RSN Technical Specifications

5.3.4 Burial Requirements

It is the intention of Purchaser to have the cable buried according to the requirements identified below in all areas where such cable burial is required.

The following marine operations may be necessary to achieve full cable burial in the relevant areas:

- Plow burial operation (together with the main laying operation)
- Post lay inspection (PLI) to determine the scope of the remedial post lay burial operations (PLBO)
- Post lay burial operation by water jetting (PLBO/J)
- Post lay burial operation by trenching (PLBO/T)

For quotation purposes, the Contractor shall assume the following scenario in each cable section to be buried as shown in the initial SLD:

- Plow burial: 90 % of the cable section
- PLI: 5 % of the cable section
- PLBO/J: 5 % of the cable section
- PLBO/T: 5 % of the cable section

These quantities may be adjusted after the laying operations.

For the shore end protection, the Contractor shall take into consideration PLBO/T or HDD.

The Contractor shall provide a detailed scope of work in relation with the above scenario including a description of the burying tools offered, their operational features and the associated plan of work. The scope of work for the above marine operations shall be reviewed and commented on by the Purchaser, and mutually agreed by Purchaser and the Contractor.

5.3.5 Repair Allowances

The Primary Infrastructure system design shall have allowances for at-sea repairs as follows without the need for extra repeater(s).

5.3.5.1 Deep Water Allowances for repair

The System shall be capable of accommodating two (2) repairs in each cable segment in the deep-water sections, while still meeting the end-of-life requirement of this technical specification.

The Contractor shall describe how this will be achieved and indicate and demonstrate the maximum numbers of clustered and distributed repairs for a set of fault scenario and repair procedures.

The Contractor shall also describe the impact of repairs involving repeaters at maximum depth.

RSN Technical Specifications

5.3.5.2 Shallow Water Allowances for repair

It is required that the System is capable of accommodating at least 1 repair per 20 km of cable in the shallow water sections with a minimum of 5 repairs in the shore end section (from beach man-hole to the first repeater or BU as applicable).

An additional loss of 0.5 dB shall be considered for each repair operation.

The Contractor shall describe how this will be achieved and indicate and demonstrate the maximum numbers of clustered and distributed repairs for a set of fault scenario and repair procedures.

5.3.5.3 Land Cable Allowances for repair

The System shall be capable of accommodating at least 2 repairs in each land cable portion, while still meeting the end of life requirements of this specification.

5.4 Cable

The primary infrastructure undersea cable and associated joints shall be of proven design and demonstrated use for fiber optic transoceanic undersea cable systems. The cable and joints shall be suitable for laying and recovery operations from current cable handling equipment and provide effective protection for optical fibers and the power conductor for the 25 year system design life. The Tyco Telecommunications SL-17/SL-21 cable families and associated Millennia and Universal joints comply with the intent of this specification and shall not require compliance demonstration with the performance requirements identified herein. Where existing supplier data is available, performance capabilities shall be provided. Modification to or selection of other cable families or joints shall require compliance demonstration with the applicable performance requirements of this specification.

5.4.1 Performance

The fibers, fiber splices, couplers, cable, cable joints, cable transitions, terminations and interconnection devices shall be designed such that the overall performance requirements can be met throughout the Design Life of the System in the environment specified herein.

5.4.2 General Requirements

The Contractor shall provide detailed dimensions, mechanical, electrical and optical characteristics of the cables and cable joints, including the qualification test programs, results, and information on deployment at sea or sea trials of all cable types requested in this Specification. If the cable has already been qualified, the Contractor shall give details of such qualification, together with any certification the Contractor may have received from any qualified body.

RSN Technical Specifications

5.4.3 Cable Structure

The cable shall have such characteristics that it can be handled by cable ship equipment without the need for significant modifications. In particular, no modifications to the normal equipment provided or working practices on a cable ship are required, either for laying or maintenance operations and no modifications shall be necessary that would prevent the cable ship from working on existing submarine cables.

5.4.4 Cable Types

Cable types suitable for use in various situations are required. The designs of the different types of cable shall ensure that they may be jointed together without undue complexity and shall be formally qualified by the Universal Joint Consortium.

5.4.4.1 Station Cable

If different from land cable, this type of cable shall be suitable for installation in the terminal station from the last manhole to the CTE.

The station cable shall be designed to ensure the protection of personnel from hazards including but not limited to high voltage, high optical power levels, and electrostatic discharge, chemical and mechanical hazards.

The Contractor shall propose a cable structure and material to be used to meet the above requirements for Purchaser approval.

5.4.4.2 Land Cable

This cable will be interconnected to the submarine cable in the beach joint. A detailed description of the beach joint shall be provided by the Contractor.

This type of cable shall be suitably protected for installation in ducts.

5.4.4.3 Submarine Cable

These types of cable and cable joints shall be suitable for installation (including burial), use, recovery and reuse in water depths specified below. They shall comprise external protection against any external agents either natural or manmade (e.g. abrasion and tension breaks). Each shall be designed for its situation and some of them, as specified below, shall be suitable for burial in the seabed where required. The types of submarine cable to be used shall meet as a minimum the following requirements:

Light Weight (LW)

This type of cable shall be suitable for deployment, operation and recovery in water depths down to 8 000 meters.

RSN Technical Specifications

Light Weight Protected (LWP)

This type of cable shall provide fish-bite protection and protection from abrasion and be suitable for deployment, operation and recovery in water depths down to 8 000 meters.

Light Weight Armored (LWA)

Cable suitable for laying, burial and recovery in depths down to 1500 meters. If not buried, the cable shall be suitable for laying and recovery in depths down to 2,000 meters.

Single Armored (SA)

Cable suitable for laying, burial and recovery down to 1,000 meters, laying and recovery down to 1,500 meters.

Double Armored (DA)

Cable suitable for laying, burial and recovery and for providing protection in depths down to 400 meters, where required. This cable is sufficiently heavy so as to be unlikely to be moved by tidal action.

Rock Armored (RA)

Where required this cable shall be suitable for deployment, operation and recovery in depths down to 200 meters. The characteristics of this cable shall provide good conformance to the seabed profiles and effective resistance to penetration by external aggression. In this type of cable the second armored layer normally has a short pitch.

5.4.5 Operating Temperature Range

The cable, cable joints and terminations shall be capable of being operated over the temperature range specified below while meeting the overall System performance.

- Cable in Deep and Shallow Water: 0°C to +35°C
- Land Cable: -20°C to +50°C

In addition, the cable at Terminal Stations shall be suitable for operation within the environmental conditions of the terminal station.

5.4.6 Cable Transportation and Storage

The cable, cable joints and terminations shall also be capable of being stored or transported during long periods at temperatures over the range -20°C to +50°C without causing any impairment to their specified performance.

The cable, cable joints and terminations shall also be capable of being handled and deployed over the temperature range -10°C to +50°C without causing any impairment to their specified performance.

RSN Technical Specifications

The cables shall be suitable for transportation, installation and storage on drums having a maximum flange diameter of 2400 mm and maximum flange spacing of 1100 mm.

Where cable drums are used to transport manufactured cable lengths, the method used to secure protective battens or identification labels to the drum shall not be such as to cause any possible damage to the cable contained within.

5.4.7 Cable Breaks and Repair

Design of the cable and jointing methods shall be such that a cable break may be repaired and the associated section restored such that no known failure mechanisms are introduced within the Design Life of the System.

5.4.8 Water and Gaseous Ingress

The design of the cable and joints shall inhibit the ingress of water and gas into its internal structure under normal operating conditions. In the event of cable damage, the maximum length of cable to be replaced due to water ingress from the point of damage shall not exceed:

- a) Deep Water: < 1 km in either direction*
- b) Shallow Water: < 0.25 km in either direction*

*Note: after the damaged cable has been left on the seabed for a period of up to eighteen (18) days at its maximum laying depth.

The Contractor shall provide information on the longitudinal penetration distance of water as a function of time and depth. Particular reference shall be made to the amount of cable that would need replacing after a failure to ensure that:

- a) No long term degradation effects attributable to water and gas ingress remains
- b) The life expectancy of the fibers is maintained following a tension break.

5.4.9 Power Feed Conductor

The cable shall incorporate a power feed conductor in order to feed power to the submersible plant. This conductor shall have DC and low frequency AC characteristics consistent with the fault location and electroding objectives as specified elsewhere in this specification.

5.4.9.1 Maximum Voltage Rating

The Contractor shall specify the maximum voltage rating of each cable type. The voltage rating must be consistent with the overall system design, segments lengths, powering configurations, worst-case voltage drops and electromagnetic voltage induction.

RSN Technical Specifications

5.4.9.2 Test Voltage and Test Duration

The Contractor shall indicate the nominal test voltage for cable sections and the duration of the test. It is expected that the combination of high voltage and test duration estimate the ability of the cable to withstand nominal operating voltage for the entire System life.

5.4.9.3 Conductor resistance

The Contractor shall specify the average conductor resistance per km of each cable type, versus temperature.

5.4.9.4 Capacitance

The Contractor shall specify the average conductor capacitance per km of each cable type, versus temperature.

5.4.10 Hydrogen and Radiation Effects

The cable and cable joints designs shall limit degradation in optical performance due to hydrogen present in, or produced by, the cable or its environment, taking into account cable breaks.

The optical transmission impairment due to the hydrogen effects shall be included in the System power budget, being supported by test results and trials.

The Contractor shall present:

- The measures which have been incorporated in the cable System in order to protect it from hydrogen sulphide generated on the sea bottom
- An estimation of the attenuation increase that may be caused by radioactive sources, relative to the intensity of radiation
- An estimation of the attenuation increase resulting from corrosion effects on installed armored cable
- An estimation of the attenuation increase resulting from magneto hydrodynamic effects along the proposed route

5.4.11 Fibers Identification

It shall be possible to identify the individual fibers in the cable both at any point of a cable section and in each repeater and branching unit.

The marker used for identification of each individual fiber shall be maintained over the whole length of the System.

RSN Technical Specifications

The Contractor shall provide in pre-installation information and handbooks, a map showing the scheme of fiber identification (optical paths, fiber types, colors, etc.) along the whole System.

5.4.12 Cable Markers

Cable markers shall be applied to the cable on the following basis:

- Markers every kilometer applied at the factory to the submarine cable suppliers standard accuracy
- Markers for each cable transition
- Markers for each cable joint
- Markers for each repeater, equalizer or BU

The type and position of markers shall be in accordance with standards usually used by the Contractor. The accuracy shall be in accordance with standard submarine telecom industry practices on a repeater span basis. Additionally for the land cable, it shall be clearly identified in every manhole.

5.4.13 General Mechanical Requirements

The cable design/inherent fiber strength shall be such that the fiber shall not significantly change its mechanical, transmission, or reliability properties before any of the requirements given below are exceeded.

The cable, cable joints and terminations shall be sufficiently robust to withstand laying, burying (to a typical depth of 1.30 meter where appropriate and possible), recovery, reuse (where appropriate), and normal handling without degrading the overall System performance or impairing their mechanical properties or that of the fiber during the System Design Life.

The cable, cable joints and terminations shall be able to sustain during the System Design Life any permanent or oscillatory tension to be expected on the sea bottom (due to current, slope, suspension, etc.).

5.4.13.1 Cable Handling

The design and construction of the cable and cable joints shall be such that no electrical, mechanical, or transmission impairment results, when in suspension over the bow of a cable ship operating in the maximum design depth of the cable for at least the period needed to make three full line cable joints.

This requirement shall be met under adverse cable ship operating conditions, such conditions being wind force eight (8) (Beaufort Scale), and a sea swell of up to 4 meters height and any adverse water currents that may exist on the route.

RSN Technical Specifications

For armored cables, the design requirement for making three (3) full line cable joints shall be met without modifying the contact points on the cable.

5.4.13.2 Cable Recovery

Cable Recovery (excluding Primary Node)

It is required that each cable type, cable joint and repeater termination, be recoverable from its maximum deployment depth at a maximum speed of one (1) knot and minimum recovery angle of 75 degrees at a sea state of up to four (4) meters height.

For each cable type, the Supplier shall provide the envelope of performance for these parameters (ship speed, recovery angle and sea swell) applicable simultaneously, recognizing potential kinking problems due to tension transients at shallow recovery depths.

It shall be possible to recover each type of cable from its maximum deployment depth from either side of transitions between two cable types.

Primary Node Recovery

It is required that each primary node, cable termination assembly, cable type, and cable joint be recoverable from its maximum deployment depth at a minimum speed of 0.5 knots and Sea State 5, with sufficient safety factor when recovered by a ship with a 30 ton capstan capability.

5.4.13.3 Cable Re-use

It must be possible to accommodate the cumulative effects of repetitive laying, recovery, repair and relaying, (after removal of a length of impaired cable) such that the cable shall still be able to sustain the residual sea bottom tension warranting transmission performance for the System's Design Life.

5.4.14 Cable Tensile Strength

5.4.14.1 General

The Contractor shall provide at PDR the following characteristics for each type of cable, and give evidence that these characteristics are adequate to respond to the encountered constraints:

- a) Nominal Permanent Tensile Strength (NPTS): the tension that the cable/fiber can support (the System staying in compliance with the performance requirements of this Specification) during the System Design Life.

RSN Technical Specifications

- b) Nominal Operating Tensile Strength (NOTS) the tension which can be applied to the cable during the time necessary to make three full line cable joints, once the cable has been recovered, without significant reduction of NPTS.
- c) Nominal Transient Tensile Strength (NTTS): the tension that can be applied to the cable during a cumulative period of one hour, without significant reduction of the NPTS/NOTS. This condition is typically encountered during recovery operations.
- d) Fiber Breaking Load (FBL): The load which when applied to the cable may result in an instantaneous fiber break.
- e) Cable Breaking Load (CBL).

For each type of cable the Contractor shall present:

- a) The fiber survival probability for cable tensions of short duration approaching the FBL.
- b) The long term probability of fiber failure due to residual cable strain following a strike approaching the FBL.
- c) Following a tension break the incremental length of cable to be removed to ensure 100% fiber survivability from stress corrosion for the Design Life of the System as well as the method of determining this incremental length.

5.4.14.2 Land Cable

The tensile strength of land cable shall be sufficient to enable pulling of the cables into existing ducts. It shall be sufficient to enable up to 1 km of cable to be drawn into a duct with two 90 degrees bends of greater than a five-meter radius. It shall be sufficient to be buried in the ground as applicable without degrading its mechanical, optical and electrical performance.

5.4.14.3 Submarine Cable

The composite tensile strength of the submersible plant i.e., cable, joint(s) and terminations is specified in the submersible equipment description.

5.4.15 Localization of Damage

In the event of cable damage from external causes, for example anchor hook-ups or trawlers, the length of cable extending from the break over which the transmission or reliability performance of the fiber is compromised shall be as short as possible and in any case no more than 1,000 meters in either direction. The Contractor shall propose the

RSN Technical Specifications

rules and criteria for evaluating the length of cable to be replaced bearing in mind water ingress requirements.

5.4.16 Reverse Bend Performance

The cable shall not suffer impaired optical, electrical or mechanical performance associated with installation and repairs.

5.4.17 Station and Land Cable Minimum Bend Requirement

The station and land cables shall be capable of being installed in situations that require it to be pulled through or left permanently in place with bends having minimum radius of 0.80 meter.

5.4.18 Abrasion Resistance

The cable shall be sufficiently abrasion resistant such that during normal cable handling and in rough ground, the outer surface of the cable shall not be significantly damaged during the Life of the System.

5.4.19 Corrosion Resistance

The finish of those surfaces of the submersible plant which will be in contact with sea water when the submersible plant is in service, excluding any deliberate sacrificial anode, shall be such that it will not suffer any deleterious effects from chemical, electrolytic or galvanic corrosion due to the presence of sea water, marine life, and/or other metals used in the construction of the submersible plant such that the performance of the System could be impaired.

5.4.20 Crushing and Impact Performance

The cable shall be impact resistant.

The Contractor shall provide the limiting values of weight and energy, due to water pressure on seabed and to accidental stress respectively, causing cable crushing and percussion so as to prevent permanent mechanical damages and/or degradation of the transmission characteristics.

The Contractor shall justify the fitness for purpose of crush and impact qualification against worst-case conditions during installation and service.

5.4.21 Torsion Performance

The torsion performance of the sea cable, joints and terminations shall be sufficient to permit it to be laid, recovered and reused without any impairment. The Contractor shall provide details of test parameters used.

5.4.22 Coiling

All cable shall coil naturally, in a clockwise direction, without the tendency to throw bights or form kinks. This requirement shall be met when the cable is manufactured, after

RSN Technical Specifications

storage in cable tanks and after recovery from its designed depth of water under the tension applied due to catenary effects.

5.4.23 Land Cable Actinic Radiation Protection

Any exposed material subject to deterioration due to actinic radiation shall be permanently protected against its effect.

The Contractor shall indicate the method of protection from actinic radiation.

5.4.24 Cable Finish

In addition to the above mentioned in the previous Sub-Paragraphs, the outer surface of the submarine cable shall be consistent with SL-17 cable type.

5.4.25 Cable Joints and Jointing Requirements

5.4.25.1 General

Provision shall be made to joint land and sea cable utilizing reproducible, reliable, economic and easily learned techniques, both on board the cable ships and in the Landing Point Parties land section jointing chambers. The requirements for compatibility of maintenance equipment and procedures defined in this Specification shall be satisfied. A joint shall not degrade the properties of the parent cable to less than 90% of tensile strength. Ultimate Tensile Strength of joints between all cable types shall be demonstrated by proof test in order to allow operators to establish safe working loads during handling.

All land cable joints shall have an earthed conductor interposed between any power feeding conductor and their outer surface.

5.4.25.2 Jointing Time

The Contractor shall indicate the time required to complete a typical joint for each type of cable.

Purchaser would find it operationally advantageous to make a complete cable joint in field conditions in a time not exceeding twelve (12) hours.

5.4.25.3 Shipboard Testing of Fiber Splice Performance

Provisions shall be made to adequately test the optical performance of any fiber splice made. The Contractor shall indicate what provisions are proposed to test both the optical and mechanical performance of the fiber splice.

5.4.25.4 Cable Joint Fatigue Performance

The cable joint shall be able to pass fifteen (15) times over a three (3) meter diameter bow of a cable ship or equivalent, when subjected to a tension equal to the NOTS of the weaker cable without any impact on the cable joint optical/mechanical performance.

RSN Technical Specifications

5.4.25.5 Cable End Seal

It shall be possible to adequately seal and earth (ground) the cut end of a cable in order to permit buoying off and powering up of the submerged system.

The Contractor shall indicate the sealing method of the cable end.

5.4.25.6 Manufactured Joints

Joints made during manufacture shall accommodate the mechanical (including dimensional) requirements of SL-17 cable type.

5.4.25.7 Universal Joints

The use of Universal Jointing techniques in the maintenance of the System shall be compatible with the submersible plant components included in the contract. The Contractor shall be responsible to ensure the qualification of all used cable types to Universal Joint prior to commencement of marine installation.

The use of such a joint over the System Design Life time shall not imply any relaxation of the contractual obligations for product, equipment and services supplied by the Contractor.

5.4.25.8 Millennia Joints

Purchaser may choose to use Millennia Jointing techniques in the maintenance of the System. The Contractor should indicate whether their cable has been qualified for Millennia Joint and that the System is compatible with the submersible plant components included in the Contract.

5.4.26 Optical Fibers Requirements

5.4.26.1 Optical Fibers Characteristics

The Contractor shall provide the list of fiber types to be used in the System, indicate the characteristics of each type and their relation to System performance.

For each fiber type, the Contractor shall provide:

- a) Fiber name
- b) Manufacturer
- c) Loss versus wavelength characteristics (min, max, average)
- d) Chromatic Dispersion versus wavelength characteristics (min, max, average), including temperature coefficients
- e) Effective Area
- f) Polarization Mode Dispersion (PMD) characteristics
- g) Non linearity parameters
- h) The cut-off wavelength, as measured by the relevant ITU-T Recommendation Reference Test Method, or any method providing equivalent results
- i) Tensile strength

RSN Technical Specifications

- j) The fiber elongation during the strength proof test and the test duration values; these values shall be such that the cumulative effect of fiber elongation during laying, recovery and of any permanent fiber elongation due to residual elongation of the cable is compliant with the System Design Life objective
- k) Splicing characteristics: Loss and Return Loss. The splicing characteristics shall be provided for all combinations of fiber types splicing, not only for splices with the same fiber type at both ends
- l) The fibers splices shall have at least the same mechanical characteristics as the specified parent fibers

5.4.26.2 Environmental Effects on Fibers

If temperature induces variations on fiber characteristics, this variation must be reversible and taken into account in the System design. The Contractor shall provide the cabled fiber attenuation for temperatures ranging within -20°C to + 50°C for land cables and 0°C to + 35 °C for submarine cables.

If other environmental conditions (i.e. laying effect, etc.) induce variations on fiber characteristics, the Contractor shall describe the effects and also indicate how this has been taken into account in the System's design.

5.4.26.3 Cabling Effects on Fibers

The Contractor shall characterize the effect of cabling on the fibers characteristics:

- a) Nominal and maximum excess loss due to cabling
- b) Slack percentage e.g. the excess length of fiber per unit length of cable

Cabling shall have no effect on the fiber life.

5.4.27 Spares

The Contractor shall provide the spares with no joint for ordered lengths below 15 km and no more than 1 joint per 15 km for greater lengths. No joint shall be at a distance less than 1 km of the span extremity.

5.5 Submarine Branching Unit (If Required)

This section has been intentionally left blank.

5.6 Primary Node

5.6.1 Overview

The Primary Nodes shall be the interface between the Primary Infrastructure and the Secondary Infrastructure's underwater science equipment.

A Primary Node shall convert incoming high-voltage DC power to lower levels that are more suitable to powering scientific instrumentation.

RSN Technical Specifications

The Primary Node shall perform the basic data server function needed to handle all command timing and data communication between the Secondary Infrastructure and the Cable Shore Station.

The Primary Node shall be designed to allow “serial expansion” of up to 6 Primary Nodes for each Cable Line from a Cable Shore Station.

5.6.2 Primary Node Input Port

The Primary Node shall have a single (1) Input Port

The decision to use or not use connectors on the Input Port shall be at the Contractor’s discretion.

If the Contractor decides to use connectors for the Input Port, the type(s) selected shall be included in the system design document along with the description of the reliability history for the connectors.

The Input Port shall support incoming High Voltage DC power with sufficient power for this Primary Node and its Secondary Infrastructure as well as the maximum number of Primary Nodes connected through cable segments to its Expansion Ports.

The Input Port shall provide sufficient transport bandwidth to meet the overall bandwidth requirements of the System.

The Input Port shall support the Timing System.

The Input Port shall support the Network Management System in controlling of the Primary Node, reporting Primary Node status, setting alarms of this Primary Node as well as all other downstream Primary Nodes connected on this cable line.

The Input Port shall support the Purchasers Observatory Management System control of the functions of the Secondary Infrastructure and report back any required system status and alarms.

The Input Port shall include an “Out-of-Band” Control/Status connection between the Primary Node and the Cable Shore Station.

The Out-of-Band Connection shall allow the resetting and or restarting of the major functions in the Primary Node and report system status and alarms of this Primary Node.

The Out-of-Band Connection shall support all other downstream Primary Nodes connected on this cable line.

RSN Technical Specifications

The Out-of-Band functionality shall be designed to operate even when the main Communication path is not functioning correctly.

5.6.3 Primary Node Expansion Ports

5.6.3.1 Primary Node Expansion Ports

The Expansion Ports shall comply with the functions of either a Pass-Through Expansion Port or a Regeneration Expansion Port that is further defined herein.

The Primary Node shall have two (2) independent Expansion Ports. The use of a Pass-Through or a Regeneration Expansion Port shall be defined by Primary Node position within the Cable Line and the allocation of bandwidth to Primary Nodes located seaward of the Expansion Port.

Selection of Expansion Port types at each Primary Node location shall be specified by the Contractor no later than SRR and shall be subject to Purchaser review.

Selection of Expansion Port types at each Primary Node location shall be specified by the Contractor no later than SRR and shall be subject to Purchaser review.

The decision to use or not use connectors for the Expansion Ports shall be at the Contractor's discretion.

If the Contractor decides to use connectors for the Expansion Port, the type(s) selected shall be included in the system design document along with the description of the reliability history for the connectors.

The Primary Node Expansion Ports shall extend the functions received on the Input Port to other Primary Nodes located on the same underwater Cable Line.

The Expansion Port shall provide outgoing High Voltage DC power with sufficient capacity such that the system can support the maximum number of Primary Nodes connected to each Segment starting at a Cable Station.

The System shall support cable segments with Primary Nodes attached to both Expansion Ports of a Primary Node with no loss of functionality.

The Expansion Ports shall extend the Timing System to all connected Primary Nodes.

The Expansion Ports shall extend the Network Management to all connected Primary Nodes

RSN Technical Specifications

The Expansion Ports shall extend the Purchaser's Observatory Management System control of the functions of the Secondary Infrastructure and report back any required system status and alarms.

The System shall meet all specifications with Primary Nodes connected between Primary Node Expansion Port and Primary Node Input Port by cable segments of up to 40 km without additional amplification or regeneration in the cable segment

The Primary Node shall enable electrical isolation of either or both Expansion Ports power signals from the Input Port power for fault isolation

The Network Management System shall monitor and report the current used by the Expansion Ports.

Electrically isolating an Expansion Port due to an excessive current situation shall not damage the Expansion Port.

The Primary Node shall allow reconnecting Power to an Expansion Port remotely under control of the NMS after the power has been disconnected.

5.6.3.2 Pass-Through Expansion Port

A Pass-Through Expansion Port shall provide sufficient transport bandwidth to meet the overall bandwidth requirements of the system.

A Pass-Through Expansion Port shall provide a passive optical communication path from/to the Input Port to/from the Expansion Port for all DWDM channels on the cable line.

Primary Nodes connected seaward of the Pass-Through Expansion Port shall *not* share its bandwidth with any other Primary Nodes that are connected shoreward.

Primary Nodes connected seaward of the Pass-Through Expansion Port shall operate *independent* of the operation of the Primary Node SIA that it has been Expanded from.

5.6.3.3 Regeneration Expansion Port

A Regeneration Expansion Port shall be capable of supporting attached cable segments of up to 40 km without additional amplification or regeneration in the cable segment.

A Regeneration Expansion Port provides an optical-electrical-optical regenerated communication path from/to its Input Port to/from the Regenerated Expansion Port via its local L-2 Ethernet Switch. The regenerated communications path will be comprised of local DWDM channels that have been allocated to that Primary Node.

RSN Technical Specifications

Primary Nodes connected seaward of the Regeneration Expansion Port share its bandwidth with Primary Nodes connected shoreward of the expanded Primary Node.

Primary Nodes connected seaward of the Regeneration Expansion Port are dependent on the operation of the Primary Node SIA that it has been expanded from.

5.6.4 Primary Node Science Port

A Primary Node shall have five (5) identical Science Ports.

Each Science Port shall include all functionality in a single ROV Wet-Mateable Connector.

The Primary Node shall include all the required electronics and optical circuitry necessary to operate all five (5) Science Ports to the full extent of their required function..

The Primary Nodes as delivered shall include wet-mateable chassis connectors on two (2) of the Science Ports with the remaining three (3) Science Ports delivered without their wet-mateable chassis connectors and the corresponding connector holes covered with a watertight covering plate.

The Primary Node Science Ports delivered without the external wet-mateable chassis connectors shall be reconfigurable by the Purchaser to add the missing wet-mateable chassis connectors to the Node and to cable those new connectors to the Primary Node's internal Science Port circuitry.

All documentation required to reconfigure the Primary Nodes to add or eliminate the wet-mateable Science Port chassis connectors shall be provided by the Contractor.

The Contractor shall deliver protective caps for all delivered Science Port wet-mateable chassis connectors that can provide long term protection for the connectors while the Primary Node is submerged and unmated to any other cable or connector.

Each Science Port shall include one (1) independent 1 GbE optical interface complying with the IEEE 1000Base-LH standard for data and control communications to the Secondary Infrastructure over a pair of fibers.

Each Science Port shall use a 1GbE optical driver with a single wavelength 1550 nm transceiver capable of driving a maximum of 60 km of single mode optical cable without additional amplification or regeneration including any losses in connectors.

Each Science Port shall provide a +375 volt DC power lead and its accompanying ground return capable of supplying up to 20 amperes of power to an external load.

RSN Technical Specifications

The 375 V output at each Science Port shall provide:

- a) Output static voltage shall be +375 +/- 5% Volt DC
- b) Output current shall be 0 to 20 amperes
- c) Output shall be protected against all short circuit currents without any permanent damage
- d) Ripple and noise with full load less than 1V p-p, 20 MHz bandwidth
- e) Regulation from no load to full load better than +/- 1%
- f) Dynamic regulation with a transient load (step from 10% to 90%) shall be better than +5% / - 10% of nominal output voltage
- g) The above mentioned requirements shall not be affected by transient loads on other Science Ports or High Bandwidth Science Ports

The Primary Node shall monitor and report through the NMS the Science Port current in the +375V power source.

The Primary Node shall under the control of the Network Management System allow setting current trip points such that if the Science Port output current exceeds the set current point the Primary Node automatically activates a galvanic isolation switch to isolate both the +375V power lead and the associated ground lead to the external load connected to the Science Port.

Activating or deactivating the galvanic isolation switch for each Science Port either under control of the NMS or due to an excessive current situation shall not damage the Science Port.

The Primary Node shall allow reconnecting Power to a Science Port remotely under control of the NMS after the power has been disconnected.

The Primary Node shall support a “soft start” of the +375V power at each Science Port with a ramping time constant of approximately 1 ms.

The Primary Node shall provide an optical 1 Pulse per Second timing signal to the load attached to each Science Port.

The 1 Pulse per Second (PPS) (Optical) Source shall be based on a 1000Base-LH optical driver @ 1550 nm wavelength capable of operating over 60km of single mode fiber cable without requiring additional external amplification or regeneration including any losses in connectors. .

RSN Technical Specifications

The 1 Pulse per Second (PPS) timing signal shall be accurate to within +/- 1 micro second with respect to a shore based GPS time clock.

The 1 Pulse per Second (PPS) timing signal accuracy requirement must be met at all Science Ports for any configuration of Primary Nodes and for the maximum allowable total distance from the Cable Shore Station.

Each Science Port shall provide a secondary low bandwidth Status/Control link to the Secondary Infrastructure.

The Status/Control link shall be multiplexed onto the 1 Pulse per Second optical signal with sufficient header characteristics to allow for easy de-multiplexing of the two signals.

The Status/Control link shall be a bidirectional serial communication path with a bandwidth of at least 9,600 Bps.

The 1 Pulse-per-Second Status/Control link shall be designed to operate even when the Science Port's main 1 GbE communication link is not functioning correctly

5.6.5 High-Bandwidth Science Port Description

A Primary Node shall have two (2) identical High Bandwidth (HB) Science Ports.

Each HB Science Port shall include all functionality in a single ROV Wet-Mateable Connector.

The Primary Node shall include all the required electronics and optical circuitry necessary to operate two (2) High-Bandwidth Science Ports to the full extent of their required function..

The Primary Nodes as delivered shall include wet-mateable chassis connectors on one (1) of the High-Bandwidth Science Port with the remaining one (1) High-Bandwidth Science Port delivered without the wet-mateable chassis connector and the corresponding connector hole covered with a watertight covering plate.

A Primary Node High-Bandwidth Science Port delivered without an external wet-mateable chassis connector shall be reconfigurable by the Purchaser to add the missing wet-mateable chassis connector to the Primary Node and to cable the new connector to the Primary Node's internal High-Bandwidth Science Port circuitry.

All documentation required to reconfigure the Primary Nodes to add or eliminate the wet-mateable HB Science Port chassis connectors shall be provided by the Contractor.

RSN Technical Specifications

The Contractor shall deliver protective caps for all delivered HB Science Port wet-mateable chassis connectors that can provide long term protection for the connectors while the Primary Node is submerged and unmated to any other cable or connector.

The HB Science Port shall include one (1) 10 GbE optical interface complying with the 10GBase-ER standard for data and control communications to the Secondary Infrastructure over a pair of fibers.

Each HB Science Port shall use a 10GbE optical driver with a single wavelength 1550 nm transceiver capable of driving a maximum of 40 km of single mode optical cable without additional amplification or regeneration including any losses in connectors.

Each HB Science Port shall provide a +375 volt DC power lead and its accompanying ground return capable of supplying up to 20 amperes of power to an external load.

The 375 V output at each HB Science Port shall provide:

- a) Output static voltage shall be +375 +/- 5% Volt DC
- b) Output current shall be 0 to 20 amperes
- c) Output shall be protected against short circuit currents of up to 20 amperes without any permanent damage
- d) Ripple and noise with full load less than 1V p-p, 20 MHz bandwidth
- e) Regulation from no load to full load better than +/- 1%
- f) Dynamic regulation with a transient load (step from 10% to 90%) shall be better than +5% / - 10% of nominal output voltage
- g) The above mentioned requirements shall not be affected by transient loads on other Science Ports or High Bandwidth Science Ports

The Primary Node shall monitor and report through the NMS the HB Science Port current in the +375V power source.

The Primary Node shall under the control of the Network Management System allow setting current trip points such that if the HB Science Port output current exceeds the set current point the Primary Node automatically activates a galvanic isolation switch to isolate both the +375V power lead and the associated ground lead to the external load connected to the HB Science Port.

RSN Technical Specifications

Activating or deactivating the galvanic isolation switch for each HB Science Port either under control of the NMS or due to an excessive current situation shall not damage the HB Science Port.

The Primary Node shall allow reconnecting Power to a HB Science Port remotely under control of the NMS after the power has been disconnected.

The Primary Node shall support a “soft start” of the +375V power at each HB Science Port with a ramping time constant of approximately 1 ms.

The Primary Node shall provide an optical 1 Pulse per Second timing signal to the load attached to each HB Science Port.

The 1 Pulse per Second (PPS) (Optical) Source shall be based on a 1000Base-LH optical driver @ 1550 nm wavelength capable of operating over 60km of single mode fiber cable without requiring additional external amplification or regeneration including any losses in connectors.

The 1 Pulse per Second (PPS) timing signal shall be accurate to within +/- 1 micro second with respect to a shore based GPS time clock.

The 1 Pulse per Second (PPS) timing signal accuracy requirement must be met at all HB Science Ports for any configuration of Primary Nodes and for the maximum allowable total distance from the Cable Shore Station.

Each HB Science Port shall provide a secondary low bandwidth Status/Control link to the Secondary Infrastructure.

The Status/Control link shall be multiplexed onto the 1 Pulse per Second optical signal with sufficient header characteristics to allow for easy de-multiplexing of the two signals.

The Status/Control link shall be a bidirectional serial communication path with a bandwidth of at least 9,600 Bps.

The 1 Pulse-per-Second Status/Control link shall be designed to operate even when the HB Science Port's main 10 GbE communication link is not functioning correctly

5.6.6 Reliability

The reliability of each Primary Node shall be such that the overall submersible plant reliability is met.

The Contractor shall provide a reliability target for the Primary Node starting from a separate reliability budget of each component type.

RSN Technical Specifications

5.6.7 Performance History or Technology Demonstration

If the Contractor proposes a Primary Node that is a proven design, it shall provide the Performance History, such as number of units in service, length of service, number of failures, etc.

If the Contractor proposes a Primary Node that is under development, or containing significant new developments with respect to a proven design, it shall organize a Technology Demonstration to explain the new features of the design, its advantages, capabilities, and the risks associated with it.

5.6.8 Mechanical Requirements

5.6.8.1 Cable ship compatibility

The Primary Node shall be of such design and dimensions that it can be handled by cable ship equipment without the need for modification. Particularly no modification shall be necessary that would prevent the cable ship from working on existing submarine cables.

5.6.8.2 Housing Strength

The tensile strength of the housing between cable anchorage points shall be at least ten percent (10%) greater than the tensile strength of any cable to which it may be connected.

The characteristics of the Primary Node and its couplers shall not be impaired after a housing has been held in suspension in cable catenary from the cable ship bow or stern sheaves to cable laying on the sea bed, for any period needed to make one (1) full cable joint, in the most adverse cable ship conditions. The depth of water in which the cable ship is deemed to be operating is that appropriate to the type of cable in the catenary.

The Primary Node housing shall protect the electronic and optical units against the hydrostatic pressure of the sea depths, provide efficient protection against the saline corrosion and provide a mechanical link between the terminations.

5.6.8.3 Termination

The termination shall ensure the optical, electrical and mechanical connections between the cable and the Primary Node, and shall be water proofed for the maximum sea depths encountered.

A break in the termination shall not damage the Primary Node housing and internal units.

5.6.8.4 Laying and Recovery

The mechanical structure of the Primary Node shall be designed to withstand expected stresses that may occur during transportation, handling, laying, burial, recovery and re-laying operations, without affecting the cable, the electronic units and the terminations.

RSN Technical Specifications

The above requirement shall be met even if operations are carried out in adverse weather conditions. The contractor shall develop for CDR recommendations for recovery and relaying weather limits.

The Primary Node shall be capable of being installed and serviced on seafloors with tilts of up to 15degrees.

5.6.8.5 Water Depth

The Primary Node shall meet all requirements installed, maintained and operated at water depths up to 3500 meters.

5.6.8.6 Dismantling

The Primary Node structure shall permit the following in the Contractor's factory environment:

- a) Dismantling for repairs of the internal units
- b) Re-assembling using the original housing

5.6.8.7 Operating Temperature Range

The Primary Node shall be capable of operating at power sufficient for testing and installation over an operating temperature range of 0 to +35 deg Celsius.

The Primary Node shall be capable of operating at full power over an operating temperature range of 0 to +8 degrees Celsius for the lifetime of the system.

During transportation and storage, the Primary Node shall be such as to withstand temperatures between - 20° C and + 40° C without affecting the System Design Life..

The Contractor shall state the recommended storage conditions for long-term storage of the Primary Node, including the permissible ranges of temperature, humidity and any other relevant environment factors.

The Primary Node must be able to be operated on board the cable ship at reduced power during laying and repair without affecting the System Design Life.

The Contractor shall be responsible for the conditions applied to the Primary Nodes during laying; he shall indicate the conditions to be applied during repairs.

5.6.8.8 Shock and acceleration

The Primary Node shall withstand the shock and acceleration that may occur during transportation, handling, laying and recovery.

RSN Technical Specifications

The Contractor shall describe the specifications for transportation and handling of a Primary Node and the packing to be used for transportation.

5.6.8.9 Water ingress limitation

The Primary Node design shall be such as to avoid, for the maximum water depths encountered, any water ingress into the housing even in case of a cable break at a short distance from the Primary Node or damage in the termination.

5.6.8.10 Hydrogen generation/ingress

The housing shall be such that at the end of the System Design Life, the internal level of humidity and the partial hydrogen pressure will not impair the performance or reliability of the Primary Node such that the requirements of this specification cannot be met.

The Contractor shall provide supporting information to satisfy Purchaser in this regard.

5.6.8.11 External Finish

The finish of those surfaces of the housing which shall be in contact with sea water when the Primary Node is in service, excluding any deliberate sacrificial anode, shall be such that it shall not suffer any deleterious effects from chemical, electrolytic or galvanic corrosion due to the presence of sea water and/or other metals used in the construction of the associated submersible cable, which may affect the performance of the Primary Node.

5.6.8.12 Shipping, Storage and handling

The Contractor shall specify all the environmental conditions to be maintained during shipping, storage and handling. The Contractor shall make sure that these conditions are monitored and met when shipping, storing and handling the Primary Nodes for this project.

5.6.8.13 Trawl Resistant Frames

Trawl-resistant design practices shall be used for all seafloor systems installed in waters up to 1500 MSW that may reasonably be expected to be fished over the lifetime of the system.

5.6.8.13 Primary Node Connectors

- a) All wet mate-able Connectors used on a Primary Node shall be designed and located to allow mate/demate by both academic style ROVs as well as large cable industry ROVs.
- b) Provision shall be made for stowing and protecting all mating connectors of cables disconnected from the Primary Node when it is removed for repair or maintenance. This provision should provide adequate protection for the connectors and pins for a period of at least one year.

RSN Technical Specifications

- c) Provision shall be made to isolate pins on wet-mateable connectors where failure to isolate a pin could cause additional damage in the event of a flooded connector.
- d) The Contractor shall provide qualification details for the proposed wet-mateable connectors for use on the Primary Nodes.
- e) All unused Primary Node connectors shall be covered with a mating dummy connector that protects the connector and pins from any damage due to external aggravation or the effects of long-term immersion.

5.6.8.14 Primary Node Seawater Ground

The Power System shall utilize a Seawater Return path (ground) from all of the Primary Nodes. Because of the type of instruments used, electric fields need to be minimized. The supplier will provide cathodes at each Primary Node and anode(s) at the Cable Shore Station of sufficient size to keep the electric current field gradient below $1\text{A}/\text{m}^2$ at any point and voltage gradient below $3\text{V}/\text{m}$. The continuous maximum current used for the design of the Seawater Ground shall be 2 amperes DC.

The anodes and cathodes shall be constructed to last the 25 year system lifetime with only minimal annual cleaning or maintenance.

5.6.9 Other Design Guidelines

- a) The use of components of proven design is preferred.
- b) The use of components qualified for use in underwater telecommunications systems is preferred. Proponents shall furnish details of their qualification program.
- c) Where COTS equipment is proposed for use in an environment other than that for which it was designed, Proponents shall furnish details of their qualification program for the COTS equipment in its new environment.
- d) To the greatest extent practical, underwater components shall be interchangeable with like components.
- e) To the greatest extent reasonably practical, all Primary Node functions shall be consistent with applicable national and international standards.
- f) The use of commercially proven, off-the-shelf or “shrink-wrapped” software is preferred. It is the Purchaser’s intent to limit the scope and risk associated with any custom software development. Where custom software development must be undertaken, this should be limited to that which is absolutely essential for meeting these Requirements.

RSN Technical Specifications

5.6.10 Management Requirements

5.6.10.1 Supervisory and Maintenance Functions

The Primary Node supervisory and control circuits shall provide the supervisory and maintenance information from the Primary Node elements. The supervisory method shall be able to detect a fault or degradation within a Primary Node.

If a Primary Node subsystem has redundant elements the supervisory system shall be able to report the status of all redundant elements and which is active in the system.

The Contractor shall provide detailed information on the supervisory method clearly showing its working principles.

The Primary Node supervisory and control circuits will be managed and monitored through the NMS.

5.6.10.2 In-service Upgrades

The Contractor shall indicate if any software in the Primary Node can be upgraded in the field and provide details on what procedures must be performed to carry it out.

If in-service upgrades are possible, the Primary Node must implement an in-situ failsafe method of recovering from a failed upgrade.

5.6.10.3 Monitoring and Control Features

The Contractor shall provide a list of the Monitored Primary Node parameters accessible by the supervisory system including their sample rates, ranges and accuracy. The monitored parameters must at least include:

- Temperature
- Humidity,
- Orientation (Tilt)

The Monitoring System shall have the capability to individually monitor the current and voltage of each of the input and output power and ground (current only) leads. The values shall be available through the NMS System to System Interface.

The Monitoring System shall have the capability to individually monitor the current and voltage of each of the Science Ports and High-Bandwidth Science Ports in addition to the ground. The values shall be available through the NMS System to System Interface.

The Monitoring System shall have the capability to individually monitor the status of all Science Ports and High-Bandwidth Science Ports. The values shall be available through the NMS System to System Interface.

RSN Technical Specifications

The Primary Node shall have the capability of monitoring and controlling the power On/Off status for each Science Port and High-Bandwidth Science Port as well as setting current limits for each of these Ports.

The NMS shall allow through its System to System Interface the ability to control the power On/Off status for each Science Port and High-Bandwidth Science Port as well as setting current limits for each of these Ports.

The Monitoring System shall prevent invalid configurations of the Primary Node that may damage the system including exceeding total current limits.

The Monitoring System shall prevent invalid configurations of the Primary Node that would put it into a state such that a Marine Repair would be required to return it a state where it can meet all of its requirements.

The Primary Node shall have the capability of monitoring and controlling the network switch settings (VPN/Port On/Off).

5.6.11 Testing

5.6.11.1 Science Port Simulator

The Contractor shall supply test hardware to the Purchaser that can be used by the Purchaser to simulate the Science Port Interface including the, Power Circuit, Communication Circuit and the Out of Band Circuit in the testing of the Purchaser's Secondary Infrastructure.

5.6.11.2 Input Port Simulator

The Contractor shall supply test hardware to the Purchaser that can be used by the Purchaser to test the sections of the Primary Node that will be maintained as spare material. This simulator shall test the nominal functions of the spared component including all functions pertaining to the, Power Circuit, Communication Circuit and the Out of Band Circuit. Full performance verification of the Primary Node may not be possible without other specialized test equipment.

The Input Port Simulator shall have sufficient functionality to verify the performance of the spare components of the Primary Nodes both on Shore and on Ship prior to deployment.

The Contractor shall provide a list of supporting equipment and special facility requirements the Purchaser needs to support the Input Port Simulator.

The Contractor shall provide documentation on the correct procedures for using the Input Port Simulator.

RSN Technical Specifications

5.6.11.3 Integration Testing

The Contractor shall provide access to a prototype functional Primary Node system with technical support for 4 weeks for integration testing with the Purchaser's system prior to CDR.

The Contractor shall provide access to either the FAT Primary Node or one of the first production units with technical support for 4 weeks for pre-deployment integration testing.

5.6.11.4 Commissioning Support Hardware

The Contractor shall develop a Science Port Test Fixture that can be used to test the functionality of a Science Port or High Bandwidth Science port Interface including the, Power Circuit, Communication Circuit and the Out of Band Circuit after the Primary Node has been deployed.

The Science Port Test Fixture shall include the proper ROV wet mate connector and be capable of being installed and replaced in the field by an ROV.

The Contractor shall provide a total of 7 (seven) Science Port Test Fixtures.

The circuitry for testing the Out of Band functionality shall be developed for dual use in both A) Commission Support Hardware, and B) the Secondary Infrastructure with minimal or no modification required.

6 Terminal Station Equipment (TSE)

6.1 General Terminal Station Equipment Requirements

6.1.1 Design Life and Reliability

The design life and reliability of the TSE (with the exception of included commercial hardware such as data switches and computers) shall be consistent with:

- The design life and reliability of the System
- End-to-end transmission performance.

6.1.2 Automatic Switching of Redundant Equipment

Automatic switching between redundant equipment shall be provided, as required, to meet the overall reliability and outage requirements:

- a) The traffic degradation due to fault detection and switching shall be the minimum possible and shall be compatible with the overall System performance requirements
- b) Indication shall be given on the TSE to indicate the in-service equipment. In the event of redundancy switching, an alarm shall be raised
- c) The redundant equipment shall be kept operating and monitored in the same manner as for the in-service equipment
- d) Redundancy switching shall not take place due to any condition or fault outside the duplicated equipment unless specifically designed to do so.

Indications of the modules currently in service shall be provided at the module level, at the equipment level and at the station level.

Manual override of the automatic switching of the redundant components shall be provided (either from the Craft Terminal or the NMS).

The status of automatic switchover of the SLTE and the PFE shall be communicated to the Management Terminal Equipment (MTE).

6.1.3 Software Requirements

6.1.3.1 Auto-discovery

The TSE equipment and facilities it supports shall be auto-discovered except for Out-of-Band hardware and PFE

RSN Technical Specifications

Equipment Auto-discovery

Each shelf connected to the management system shall be auto-discovered.

When a card/module is inserted into a shelf, it shall be auto discovered.

If a card is inserted in a slot for which it is not designed, the auto-discovery sub-system shall detect and alarm the condition.

The auto-discovery function shall automatically indicate:

- The card type
- The card Hardware release information
- The card Software release information
- The card unique serial number
- The service status
- Other relevant information (e.g. card specific parameters such as wavelength etc.)

Facility Auto-discovery

The hierarchy of facilities shall be clearly auto-discovered e.g. optical fiber facility, wavelength facility and payload

The auto-discovery function shall automatically indicate:

- The Terminal equipment
- The intermediate equipment
- The service status
- The optical power levels
- The number of channels present
- The number of channels in-service
- The payload in each channel
- Associated performance parameters

6.1.3.2 Software Upgrades

Software upgrades will be controlled by the Purchaser.

6.1.3.3 In-service Software Upgrades

Upgrades must be feasible with all equipment/facilities in service and carrying live traffic except for Out-of-Band hardware and PFE.

Software upgrades shall minimize the effect on the System traffic.

Upgrades must be automated as much as possible.

It shall be possible to upgrade all the hardware in a minimum number of manual steps.

Manual updates of individual cards one at a time are not acceptable.

Upgrades must be performed in a reasonable amount of time e.g. minutes.

RSN Technical Specifications

6.1.3.4 Un-doing Software Upgrades

It shall be possible to undo a software upgrade by reverting to the original software release.

6.1.3.5 Inventory Data

The Contractor shall implement a process for collecting and displaying all inventory data. The inventory data shall be in a format that can be exported in commonly used software (e.g. MS Excel).

6.1.3.6 Alarms Severity

Each alarm shall have a default severity.

The List of Alarms Severity shall be reviewed by and agreed by Purchaser before the beginning of manufacturing.

In some cases, the User shall have the capability to change the alarm severity. The Authority level to change alarm severity shall be Administrator.

6.1.3.7 Adjustable Thresholds with Defaults

Alarms that relate to quantitative parameters shall have thresholds clearly indicated by the Management System.

There shall be a default threshold for each one.

When appropriate, it shall be possible to provision the thresholds to non-default values. This shall apply to quantities such as optical power levels, error counts, voltages, currents etc...

The management system, through the GUI, shall tag the non-default thresholds (e.g. use a different font type or color).

It shall be possible to reset the thresholds to the factory values.

6.1.4 Unit Removal Detection

Card removal shall be alarmed except for OOB and PFE hardware.

Filler card presence and removal shall be alarmed.

RSN Technical Specifications

6.1.5 Thermal Management (fans, etc.)

The Contractor shall describe the thermal management system of the TSE, in particular:

- Number and power of fans per shelf and/or per rack
- Airflow requirements e.g. front only, front and back, etc...
- Number of failed fans that can be tolerated for a long time (e.g. days)
- Number of failed fans that cannot be tolerated
- Thermal shutdown mechanism (if any), related alarms
- Air filters, cleaning and in-service replacement procedures, access
- Over-temperature alarms, redundancy of alarms, alarms severity

The thermal management sub-system must be compatible with the overall reliability and availability performance requirements for the Life of the System.

6.1.6 Ambient Conditions

6.1.6.1 General

The Ambient Conditions described shall apply to all the Terminal Station Equipment. The ambient temperature shall be that measured at a height of 1.5 m above the floor and 0.4 m from the face of the rack.

If a given temperature range for a given piece of equipment does not comply with the general requirement, the Contractor shall indicate the exception to Purchaser.

6.1.6.2 Normal Ambient Conditions

The equipment shall operate at ambient conditions as indicated in ETSI requirement ETS 300 019-1-3:1992, Class 3.1, complying with the performance requirements. The Contractor shall indicate if fans are used within the equipment and whether they are essential to ensure the equipment meets the performance requirements of this specification. The Contractor shall provide sufficient quantities of spare fans for the System Design Life based upon the reliability requirements of the fans. If filters are used the Contractor shall provide sufficient spares for the System Design Life or proven cleaning procedures. Replacement or cleaning of the fans and/or filters shall not affect the traffic.

6.1.6.3 Severe Ambient Conditions

The equipment shall operate at ambient conditions as indicated in ETSI requirement ETS 300 019-1-3:1992, Class 3.1E, but not necessarily fully complying with the performance requirements. The equipment shall revert to normal performance after the normal ambient conditions, as specified above, have been restored.

The Contractor shall indicate the performance degradation to be expected and the maximum part of the time the TSE can be operated in these conditions in order not to affect the System's Design Life.

RSN Technical Specifications

6.1.6.4 Transport Ambient Conditions

The equipment adequately packed shall, during transport, withstand the ambient conditions indicated in ETSI requirement ETS 300 019-1-2:1992, Table 1, class 2.3 without causing impairment to the equipment performance and life.

Exposure of properly packed equipment to ambient conditions indicated in the previous Paragraph shall not exceed 30 days.

6.1.6.5 Storage Ambient Conditions

The unpacked equipment shall withstand during temporary storage the ambient conditions indicated in ETSI requirement ETS 300 019-1-1:1992, Class 1.1 without any damage.

6.1.7 EMC/ESD Conditions

In lieu of testing to the below requirements, the equipment shall be designed with consideration of the following EMC/ESD standards and requirements:

6.1.7.1 Electromagnetic compatibility

The equipment shall be designed with consideration of EN 50081-1, EN 50082-1 and EN 55022. It shall also be designed with consideration of ES 201 468 "Electromagnetic compatibility and Radio spectrum matters and additional electromagnetic compatibility requirements for telecommunication equipment for enhanced availability in specific applications for the locations other than telecommunication centers, level 2".

6.1.7.2 Electrostatic Discharge

IEC 61000-4-2 (formerly 1000 PT 4-2) issue 1.2, dated 2001 Electrostatic Discharge:

Test level 2: Test result 1 (normal performance)

Test level 3: Test result 2 (reduced performance)

Test level 4: Test result 3 (loss of functionality, e.g. customer reset)

6.1.7.3 Conducted Susceptibility

IEC 61000-4-4 (formerly 1000 PT 4-4) issue dated 1995 Electrical fast transient/burst immunity, level 2 (normal performance)

IEC 61000-4-5 (formerly 1000 PT 4-5) issue dated 1995 Surge Immunity, level 2 (normal performance)

IEC 61000-4-6 (formerly 1000 PT 4-6) issue 1.1, dated 2001 Conducted Interference, level 2 (normal performance)

6.1.7.4 Radiated Susceptibility

IEC 61000-4-3 (formerly 1000 PT 4-3) issue 1.2, dated 2001 Radiated Immunity, level 3 (normal performance)

The immunity to the radiated electric fields shall comply with carrier frequency at 900 MHz, 1 300 MHz and 1 800 MHz)

RSN Technical Specifications

6.1.7.5 Conducted Emissions

IEC CISPR 22 issue 3 dated 1997 Class A Radiated & Conducted Emissions from Information Technology Equipment

6.1.7.6 Radiated Emissions

IEC CISPR 22 issue 3 dated 1997 Class A Radiated & Conducted Emissions from Information Technology Equipment

6.1.7.7 Electric Field

The electric field shall be measured in the range:

30 -1000 MHz according to IEC CISPR 22 Class A, $E < 47\text{db} (\mu\text{v/m})$

1000 -2000 MHz, $< 47\text{db} (\mu\text{v/m})$ and measuring method as IEC CISPR 22.

6.1.7.8 Magnetic Field

The magnetic field shall be measured in the range 10 kHz – 30 MHz, at 1 meter of the equipment. The requirements are given in Table 2 below for three types of equipment:

- a) Static power feeding equipment ($> 5 \text{ kVA}$)
- b) Video Display Terminals (with CRT)
- c) Other equipment

The magnetic field shall be measured in the range 10 kHz - 30 MHz, at 1 meter of the equipment.

FREQUENCY (MHz)	STATIC POWER FEEDING EQUIPMENT ($>5\text{kVA}$)	VIDEO DISPLAY TERMINALS (with CRT)	OTHER EQUIPMENT
0.01	66	56	46
0.15	66	56	46
1.6	20	10	16
30	20	10	16

Table 2 – Magnetic Field H (dB(uA/m))

6.1.8 Shock and Vibration

The Contractor shall be responsible for safe handling and transportation of the equipment.

The Contractor at PDR and CDR shall provide the shock and vibration limitations applicable to the packed and unpacked material during transportation, which are compliant with IEC 721, ETS 300 019-1-1, ETS 300 019-1-2 and ETS 300 019-1-3 recommendations.

6.1.9 Marking, Face Layout and Designations

The marking, face layout and designations of the equipment shall be in accordance with the following requirements:

RSN Technical Specifications

6.1.9.1 Face Layout

The function of each plug-in unit shall be apparent from its designation and from its relative location. The direction of the signal paths between plug-in units and between shelves shall form a horizontal and vertical progression. This layout shall be the same on all TSEs and for the set of spare cards.

6.1.9.2 Controls, Supervisory Indicators and Connectors

The function of controls, supervisory indicators and test points shall be readily apparent from its location, designation or coloring, or a combination thereof. Controls or connectors that represent a safety hazard to personnel or to the System shall be so identified and protected as necessary. The variety of controls and connectors to be used shall be a minimum consistent with the above requirements.

Regularly used operational controls, supervisory indicators and test points shall be mounted at convenient working height. Supervisory and frequently used controls (including items such as handsets) may be left exposed. Rack supervisory indicators shall be visible from the end of the suite in which the rack is sited.

6.1.9.3 Non-Operational Controls

The equipment shall be designed such that non-operational controls, fuse holders and all meters, except those which indicate voltages, currents and other relevant parameters at principal points in the PFE, are placed out of sight from the normal operating positions but made reasonably accessible for maintenance and acceptance purposes, e.g. hinge-down flaps.

6.1.9.4 Equipment Color Scheme

The surface finish shall be durable for the life of the System.

6.1.9.5 Designations

Racks, shelves and cards shall show their relative designations. Adequate designations shall be printed at each test, alarm and control point, etc. Alternatively the Contractor may propose other arrangements for the approval of Purchaser.

Designations of jacks, meters, test points, etc. printed on the equipment shall be in English language.

6.1.10 Equipment Status Indication

6.1.10.1 General

Alarm arrangements shall be provided to indicate any malfunction or off-normal condition of equipment. The alarm signal shall be supplied continuously until the malfunction or off-normal condition is cleared or until an alarm has been acknowledged as receiving attention.

RSN Technical Specifications

6.1.10.2 Alarm Types

Two categories of alarms are required:

A prompt alarm, which is an alarm that requires attention at all times.

A deferred alarm, which is an alarm that does not require immediate attention but nevertheless gives notice that attention, is required.

It shall be possible for each alarm to be connected to either one of the alarm categories.

6.1.10.3 Alarm Indicators

The alarm indicators shall be audible and visible (LED or lamp). A separate indication shall be provided on each rack to indicate the presence of power supply failure. Failure of the power supply shall result in an alarm signal being extended to the station alarm system. Details of the alarm indicators shall be presented at PDR.

6.1.10.4 Receiving Attention Facilities

Each alarm condition shall have independent receiving attention facilities to avoid one alarm masking another. An audio alarm system shall be reactivated when an alarm appears after acknowledgement of a previous one. Details of alarm priorities shall be presented at PDR and CDR.

6.1.11 Connection to the Station Alarm System

Appropriate provisions shall be made by the Contractor to connect the individual equipment collective alarm indications to the station alarm system.

6.1.12 Remote Terminal Station Indication

As a minimum, it shall be possible to display distant TSE conditions, transmitted within the System:

- Power feed current and voltage values
- Loss of received line signal (optical power and/or modulation)
- Receive degraded, if applicable
- Transmit degraded (optical output power and/or modulation)
- Transmit fail (no power)

6.1.13 Supervision of Equipment

The TSE shall include Element Managers for monitoring, presenting, and storing the information obtained from the appropriate network elements.

The equipment shall process all alarms.

RSN Technical Specifications

6.1.14 Power Supplies

This section has been intentionally left blank.

6.1.15 Construction Practices

6.1.15.1 Racks

The Terminal Equipment shall be installed in racks of metallic structure. Rack installation back-to-back, side-to-side or against a wall shall be possible.

The equipment practice shall preferably require only front access for installation, operation and maintenance.

Station cabling and inter-rack wiring shall be possible through the top or through the bottom of the rack. Rack cabling and connectors shall be completed for its ultimate capacity, whether the rack is fully equipped or not.

The racks shall preferably be closed by doors that can be locked.

The design of the racks shall be compatible with all thermal and EMC/EMI requirements.

6.1.15.2 Electronic units

The electronic units shall be of a plug-in type and shall be capable of being mechanically secured at the front of the equipment to prevent inadvertent removal.

It shall be possible to plug and unplug any unit in powered conditions, even in a non-appropriate slot, without causing any damage to the additional unit and to the in-service units and without affecting the operation of in-service equipment except for OOB and PFE.

It is preferred that printed circuit boards be lacquered or especially protected in order to prevent any corrosion effect. The use of sliding-contact potentiometers in the transmission path is prohibited.

The Contractor shall be responsible for safe handling and transportation of the equipment.

6.1.16 Equipment Fault Location and Repair

To the greatest extent reasonably practical, it is preferred that TSE faults can be readily located to a particular card. Repair shall be performed according to the repair and return procedure described in the System Description.

To the greatest extent reasonably practical, the TSE shall include a self-diagnostic feature to enable rapid localization of faulty replaceable units.

6.1.17 Safeguards to Service

6.1.17.1 Reliability

The quality, reliability and maintenance plan of the TSE must be such that the end-to-end

RSN Technical Specifications

System performance and outage requirements are met throughout the life of the System. The nominal terminal reliability parameters (e.g. the MTBF, MTFE and the MTTR), taking into account any duplication of the equipment, the room temperature, etc., shall be detailed in the documentation given with the RFP.

6.1.17.2 Components and Materials

The properties of all components and materials used shall be selected according to their application and be such as to withstand, with an adequate margin of safety, the highest design stresses (including voltage, temperature, etc.) to which they could be subjected within the equipment.

The following materials shall be subject to local safety requirements:

- a. Flammable materials
- b. Radioactive materials
- c. Beryllium oxide
- d. Asbestos

The Contractor is requested to inform Purchaser if its system contains any of the above mentioned materials.

6.1.18 Remote operation of the Terminal Station Equipment

The TSE shall be capable of being controlled and monitored remotely from a workstation without the need for presence of operating personnel at the Terminal Station. The PFE may not be turned on remotely for safety reasons.

6.1.19 Craft Terminal

A craft terminal shall be provided in each cable station to support all user functionality for all Terminal equipment.

The Contractor shall provide a detailed specification of the craft terminal (speed, capacity, etc.) and detailed list of the craft terminal functionalities.

6.1.20 Supervisory and Alarm Arrangements

The TSE shall contain supervisory, alarm and test/monitor point facilities, as detailed in this Specification, to give an indication of System performance whilst carrying traffic and to assist in the location of faults.

The alarm detector shall be placed as near as possible to the function under control in order to avoid ambiguity with any other terminal fault.

The Contractor shall provide a detailed description of the alarms characteristics (ON/OFF conditions, time diagrams, etc.). Alarms instabilities and transient alarms must be avoided.

RSN Technical Specifications

6.1.20.1 Equipment Faults

TSE fault location shall typically be carried out by substitution of plug-in units in conjunction with supervisory indicators and monitor point such that a faulty plug-in unit can be unambiguously identified by the use of a clearly defined fault finding strategy.

Detailed information on indications and procedures for locating faulty TSE units by the alarm system shall be provided at PDR and CDR.

6.1.20.2 Test and Monitor Facilities

Facilities shall be provided on the TSE to enable the System's performance and traffic to be monitored, either from test points or the Craft Terminal or on the MTE.

The equipment performance shall not be affected by the connection of any impedance (including a short circuit) to the test points, neither shall damage result.

The same type of test point connector shall be used throughout the equipment when possible. The connectors shall be placed on the front edge of the appropriate card and shall be accessible during normal operation whenever possible. The Contractor shall provide a List of test points.

The test points provided in COTS equipment will be identified at PDR and CDR.

6.1.20.3 Submersible Plant Monitoring

The TSE shall include facilities for monitoring repeaters, to enable cable section and repeater faults to be located with the minimum of ambiguity with the System powered

The monitoring equipment provided in the TSE shall be designed to prevent inadvertent interruption to traffic when in use.

6.1.21 Other Requirements

- a) An optical fiber connector shall be provided on each fiber to allow optical tests to be carried out on the submersible plant. There shall be no active components between the connector and the seaward side.
- b) It is preferable to have only one type of optical connector where possible within the TSE and the Contractor shall indicate all types of connectors used in the SLTE.
- c) The design of the TSE shall be such that units plugged into an incorrect location shall not cause electrical or mechanical damage to any part of the equipment.
- d) Covers shall be installed for any unused slots, shelves or racks.
- e) The Contractor must provide interfaces to the Purchaser's Backhaul using aggregated increments of 10GbE.

RSN Technical Specifications

6.1.22 Protection of Operating Personnel

The TSE shall be designed to ensure the protection of operating personnel as regards the maximum optical power density that it may be possible to receive at the outer surface to either eye, as well as electrical, chemical and other hazards.

The Equipment shall meet all legal requirements of the landing point countries. It is the Contractor responsibility to determine these requirements.

Appropriate warning notices shall be fitted at all places where dangerous voltages exist.

Plug-in units for sub-assemblies taken out of service for maintenance purposes shall be safe for handling and testing by station staff.

6.1.23 Earthing and Bonding

The bonding network of the equipment and its interconnection with the station earth shall comply with the local building codes.

6.2 Transmission Terminal Equipment (SLTE)

6.2.1 Scope

This chapter describes the technical requirements for the SLTE that are not defined in the General Requirements.

6.2.2 Architecture

The Contractor shall describe the architecture of the SLTE, including the particular functions of each card within a shelf, each shelf within a rack and each rack. Interfaces between entities with different functionality (e.g. transponders, control cards, passive optical multiplexers, optical amplifiers, chromatic dispersion compensator, etc.) shall be clearly described.

6.2.3 Redundancy Architecture Availability

This section has been intentionally left blank.

6.2.4 Dispersion Compensation Support

The Contractor shall describe the CD compensation system in the SLTE. The maximum CD error at the SLTE input (positive, negative) shall be specified.

6.2.5 Management Interfaces

The management interface is TCP/IP SNMP for alarms.

The Contractor will provide redundant servers for each cable station.

Backdoor access through a modem connected to the Internet shall be provided.

RSN Technical Specifications

6.2.6 Signal Interfaces

The signal interfaces of the SLTE are to be defined by the Contractor.

6.2.7 Power Dissipation per wavelength

The Contractor shall indicate the Power Dissipation per wavelength (transmit and receive).

6.2.8 AIS Generation and Handling

AIS generation and handling is to be defined by the Purchaser.

6.2.9 ALS and APR (Automatic Laser Shutdown and Automatic Power Reduction)

ALS and/or APR functionality shall comply with the Local regulations in terms of optical safety.

ALS and/or APR shall be clearly described by the Contractor documentation, including methods of operation, optical thresholds, optical levels, etc.

It shall be possible to disable the ALS/APR feature for maintenance purpose.

6.2.10 Integrated Test Equipment

The Contractor shall indicate if integrated test equipment is available as an option in addition to the standard monitoring equipment.

Integrated test equipment can be:

- Integrated Optical Spectrum Analyzer (OSA)
- Integrated OTDR and C-OTDR

6.2.11 Transmission Tolerance to Management Sub-system Failure

SLTE transmission performance shall not be impacted by total management sub-system failure.

6.2.12 Transmission Tolerance to Cards Insertion/Removal (In-service)

The design of the SLTE cards shall be such that they will tolerate multiple in-service insertion and removal cycles.

The number of insertion/removal cycles shall be consistent with the System Life and expected maintenance activity.

Preferably each card shall be able to be plugged in while the system is operating.

Each insertion and/or removal shall:

RSN Technical Specifications

- Have no impact on the SLTE transmission performance of all the channels not directly affected by the card
- Not produce any significant surge that could (a) fail the EMI/EMC environmental specifications and (b) reduce the card Life and its neighbors Life
- Not produce any significant mechanical wear that could reduce the card/shelf Life and its neighbors Life
- The Contractor shall indicate the design number of insertion/removal cycles

6.2.13 Performance Monitoring Support

The SLTE shall support Performance Monitoring for all the critical parameters.

6.2.14 Performance

The overall performance of each SLTE path in each direction of transmission between the System Interfaces shall meet the agreed performance limits:

- a) For any ambient temperature change within the range specified
- b) For any change in supply voltage within its overall limits

6.3 Management Terminal Equipment (MTE)

6.3.1 Scope

The Management sub-system Management Terminal Equipment (MTE) shall provide a single human computer interface for monitoring and controlling all the Terminal Station Equipment (TSE) and all the submerged plant of the System.

The MTE shall be made of Element Management Systems (EMS) and a centralized Network Management System (NMS).

The Element Management Systems shall be provided at each Terminal Station for each Network element including the PFEs and Primary Nodes.

The NMS shall be capable of monitoring, maintaining and controlling the whole of the System.

The details of the different scenarios for re-configuration shall be mutually agreed upon by Purchaser and the Contractor at PDR and CDR. Power reconfiguration shall be provided through NMS control of the Command Channel Equipment and PFE adjustments. Methods of Procedures for power reconfigurations shall be provided as part of the End User Documentation.

The MTE shall supervise, and control, where applicable:

- The Management Terminal Equipment made of SLTE, PFE and itself

RSN Technical Specifications

- All submerged plant (Repeaters, Primary Nodes, Fault Reconfiguration)
- The MTE shall have the ability to incorporate discrete alarms from other sources, such as environmental alarms (at the Cable Shore station or Primary Nodes, as well as downstream (Secondary Infrastructure equipments). As well as the means to database these additional discrete alarms.

6.3.2 Architecture

The Contractor shall describe in detail the architecture of the MTE at PDR and CDR.

6.3.3 Future Proofing

All Commercial Off the Shelf equipment (COTS) used in the MTE shall be designed with components that are in current production status at the time of Provisional Acceptance. The Contractor shall provide all End Of Life notices for any COTS MTE to the Purchaser for five years after Provisional Acceptance.

6.3.4 Backdoor Access

Redundant access through a modem connected to the Internet shall be provided for the Shore Station.

The redundant access shall provide all features available to the in-band remote connection to the NMS.

6.3.5 Equipment

If some part of the MTE is made of proprietary equipment built in shelves, the Contractor shall describe the Equipment rules for those shelves.

This equipment shall comply with all the General Requirements related to Terminal Station Equipment (TSE).

6.3.6 Integration with “Standard” IT Equipment

It is Purchaser preference to have the MTE made of “Standard” IT equipment, when possible.

6.3.7 Types of Power Feeds, Power Redundancy

The Contractor shall specify the power requirements of the MTE equipment and PDR and CDR.

6.3.8 Power Dissipation (typical)

The Contractor shall specify the MTE power dissipation. Thermal management shall comply with the General requirement.

RSN Technical Specifications

6.3.9 Submersible Plant Supervision

For submersible plant the MTE shall provide the following functionality:

- a) Status/performance monitoring of parameters such as optical gain, optical levels etc.
- b) Fault location, detection of degraded or faulty components, and determination of the location of cable faults
- c) Semi-automatic or manual corrections as appropriate
- d) Regular Line routine monitoring; scheduler
- e) Supervisory co-ordination e.g. elimination of the possibility to have supervisory activity enabled on the same components at the same time
- f) Submersible plant control
- g) PFE voltages and currents monitoring
- h) Primary Node Science Port voltages and current monitoring
- i) Primary Node Science Port current trip limit settings.
- j) Primary Node engineering sensor data.

6.3.10 Terminal Equipment Supervision

For Terminal Equipment the MTE shall provide the following functionality:

- a) Status display
- b) Performance monitoring
- c) Fault diagnostics
- d) Alarms processing
- e) Automatic corrective actions as appropriate

Indications of the modules currently faulty shall be provided at the module level, at the equipment level and at the station level for the TSE.

6.3.11 MTE Redundancy

The MTE shall include redundancy features that will allow management of the System in case of failure of a critical component. The list of critical component is, but not limited to: a computer, processor, memory, hard disk or other storage device, a data communication link.

The redundancy features and options shall be described by the Contractor.

6.3.12 Alarm and Performance Information Acquired by the MTE

All alarm and performance information generated by the TSE and submerged plant shall be passed to the MTE and shall at least include the information detailed in this specification. Additionally any System inventory information that can be acquired directly or indirectly from the TSE and submerged plant shall be made available to the MTE.

RSN Technical Specifications

Logging and recording facilities provided shall include the equipment and techniques necessary to analyze and present the results recorded. Results shall be presented both graphically and in tabular form. The graphical presentation application shall include tools for analysis that enable graphical processing such as zooming and scaling. The graphs and tables shall be in such a format that they can be exported to commonly used software for further analysis and/or generation of reports and presentations.

6.3.13 Alarm Masking

A TSE or submerged plant fault may produce a series of subsequent alarms, which are more or less interdependent. The MTE shall acquire record and date all these alarms in their chronological order,

The Contractor shall provide a description of the alarm masking

6.3.14 Control Required by the MTE

User configurable features of the Terminal Equipment and all the configurable features of the submersible plant can be performed from the MTE. MTE access to the configurable features shall be enabled/disabled by applying User Access rights to the MTE functions. Details of the configurable features will be provided by the Contractor.

6.3.15 Event Management

Upon receipt of an event from the Terminal Equipment or the submerged plant, the MTE shall:

- a) Time stamp the event using a UTC, GPS traceable time stamp
- b) Store the event in a database
- c) Activate an audible indication on the MTE of sufficient volume to attract the attention of the Maintenance Personnel. This indication shall continue until the operator acknowledges the event. Audible alarms and events are either globally enabled or disabled through MTE.
- d) Store the event in an event log and print the event log on a Printer when desired. It shall be possible to print events without affecting the other actions that the MTE undertakes upon receipt of an event
- e) Display the event in a scrollable window on the Human Computer Interface (HCI)

All received events shall be displayed in the event log window in chronological order. The Contractor shall state how many events are visible in the event log window at one time. By default, the latest event shall be displayed at the top of the event list. The display shall include all relevant information to that event including the date and time stamp as assigned by the MTE. The Contractor shall state the accuracy of the time stamp over system life and describe the mechanism for ensuring accuracy of the time stamps. The

RSN Technical Specifications

time stamping accuracy shall be better than or equal to 1 second with respect to UTC. The format for date and time shall be user configurable.

The Contractor shall provide information to demonstrate that the MTE can cope with the event flow generated by the worst case failure event within the System. The Contractor shall describe any prioritization and contention processes within the MTE.

Alarm clearing shall be considered an event and processed with the same method as all other events. The MTE shall be capable of associating an event clear report with the original event report.

The MTE shall be provided with size limited current and historic alarm logs. An alarm shall be raised when either of the logs are 80% full. Both logs shall be capable of backup and shall wrap round when full. These mechanisms shall be agreed with Purchaser. The event log shall be capable of being backed up so that the data can be later retrieved into the MTE. Retrieval of Logs shall not interfere with the normal logging of events. The Contractor shall indicate the size of the event log.

In case of MTE failure the retrieval process shall easily and quickly be achieved.

The MTE shall be capable of performing a sorted search by event type, severity, date, start/end time range, status (set or clear), plug-in unit, NE or combinations of these. The Contractor shall describe any additional search criteria that are available. It shall be possible to print and export the results of the searches.

6.3.15.1 Event Correlation

Event correlation at the MTE shall be limited to correlation between the individual pieces of equipment that make up the System. The aim shall be to give one resultant event to the MTE due to a fault occurring in a line system

A user configurable scrollable window shall display alarms/events in chronological order according to the time stamp of the received alarms/events. The time stamp will be accurate to within one second or better. The window shall be able to be configured to display only alarms/events of a defined severity, or with a defined origin, or within a defined time period. The tool to define those windows is a filter.

Priority shall be given to processing of primary events.

6.3.15.2 Alarm Events

It shall be possible to display in a scrollable window all currently active alarms. The Alarm severity shall be indicated in the color assigned to that severity. It shall be possible to print and export the active alarm summary.

Alarm event priorities are pre-programmed.

It shall be possible to adjust all user configurable alarm limit thresholds, either remotely

RSN Technical Specifications

at the MTE or locally at the craft. The Contractor shall indicate the Terminal Equipment alarm thresholds and priority levels which can be adjusted System the MTE.

It shall be possible to reset each alarm severity and/or alarm limit threshold to its default/factory value.

6.3.16 Performance Management

All TSE and submerged plant performance information shall be processed by the MTE.

6.3.16.1 Processing of Performance Information

The MTE shall process all performance information received from the TSE and submerged plant, e.g. received light level, error performance etc.

6.3.16.2 Performance Database

The MTE shall maintain a performance database that shall store all the System Terminal Equipment and submerged plant performance information.

It shall be possible to print, export in a specified format and/or store on the MTE the results of the above functions.

The MTE shall be able to produce daily logs of all performance information.

6.3.17 Configuration Management

The MTE shall be responsible for maintaining a record of the component parts of the Terminal Equipment and submerged plant. The Contractor shall state what Build and Inventory information is associated with each piece of equipment.

The MTE shall also be capable of automatically updating information concerning the inventory of component parts of the Terminal Equipment, including both hardware and firmware build, System the auto-discovery feature.

6.3.18 Security Management

6.3.18.1 Access Security

Individual user profiles shall be configurable by the highest operational class of user.

Classes of users shall be agreed with Purchaser.

It shall be possible to define and enforce passwords ageing policies.

6.3.19 Terminal/Workstation to MTE Interface

The terminal workstation runs a dedicated client application and is connected to the server System TCP/IP and proprietary messages.

RSN Technical Specifications

6.3.20 Human Computer Interface (HCI)

Graphical User Interface (GUI) features shall be used. The HCI shall give multi-leveled views of the equipment under the control of the MTE. The top-level view shall be of the system being controlled on a background geographical map. Component parts of the system shall be represented by screen icons. It shall be possible to zoom into an equipment icon by a point and click mouse operation. At this second view level it shall be possible to display all management information of the equipment. The third level shall display a front view picture of the equipment showing the card layout and any visible alarms on the cards. The front layout display shall show on screen real time alarm status changes. At any level the icons shall indicate alarm status by color change. It shall be possible to assign any color to each of the alarm priority types.

Help Function: Associated with each alarm condition displayed on the MTE shall be a subject sensitive help function.

It shall be possible to print any of the information displayed on the HCI.

The HCI shall provide real-time indication of which parts of the PFE is powering the submarine sub-system. It shall not be necessary to refresh the information manually.

6.3.20.1 NMS Server

This is the computer equipment where the NMS application is resident.

6.3.20.2 Hardware

This shall consist of a computer system operating under an internationally recognized operating system, which shall be stated by the Contractor. Contractors shall provide at least the following information:

- a) The stated processor, its manufacturer, its rated processing power in MIPS and its model number.
- b) The sizes of disk storage
- c) The sizes of main memory
- d) The communications implementation
- e) The terminal interface implementation
- f) The operating system
- g) A list of proprietary software
- h) Printer interfaces
- i) Monitor characteristics
- j) Recommended spares holding
- k) Software update period
- l) Backup Mass Storage characteristics
- m) Any other pertinent information

The NMS server storage capacity shall permit one year storage. The Contractor shall provide mass storage, backup and data transfer facilities for long-term storage.

RSN Technical Specifications

6.3.20.3 NMS and MTE Software

All MTE software shall be written in an internationally recognized language. The Contractor shall state which language is used.

The Contractor shall describe the licensing arrangements for any proprietary software used within the MTE.

The software shall be supported on an industry standard hardware platform.

6.3.20.4 Furniture

The Contractor shall provide sufficient furniture (i.e. desk, chair, printer stands etc.) to house the MTE hardware in a tidy and safe manner. All electrical wiring shall conform to local building codes.

6.4 System to System Interface for MTE

This chapter describes the requirements for an interface between the MTE and the purchaser's external Observatory Management System (OMS).

6.4.1 General

The MTE shall provide a System to System Network Management Interface.

It shall be possible to obtain alarm, status and performance information from all network elements of the Terminal Equipment and submerged plant System from the System to System Interface.

It shall be possible to control and set alarm thresholds for all network elements of the Terminal Equipment and submerged plant System from the System to System interface including setting Primary Node Science Port configurations and current thresholds.

6.4.2 System to System Interface

The System to System Interface shall be based on TCP/IP.

The System to System Interface must have sufficient bandwidth such that all Terminal Equipment and submerged plant systems can be monitored and controlled simultaneously.

To allow the necessary implementation by Purchaser to interconnect to their external OMS, the Contractor shall provide Purchaser with complete documentation of the System to System Interface and protocol.

The Contractor shall provide a simulator software application that can be used by the Purchaser to test the System to System Interface.

RSN Technical Specifications

The Contractor shall provide access to a prototype system with technical support for 2 weeks for integration testing of the System to System Interface.

The Contractor shall provide access to a final system with technical support for 2 weeks for pre-deployment integration testing of the System to System Interface.

The Contractor shall provide a means for Commissioning the System to System Interface independent of the OMS.

6.5 Software

Any software to be provided for the System shall be modular in structure, preferably written in internationally recognized high-level language, and shall be fully protected against changes being inadvertently introduced during operational use. The Contractor shall provide software support throughout the System Design Life. In particular, the Contractor shall ensure suitable software adaptation or supply the necessary information shall the replacement of hardware become necessary due to discontinuation of maintenance support by the Contractor of the computer hardware. In such a case, the Contractor will advise Purchaser of suitable replacement hardware.

The Contractor shall not include in the Software any facility that is not described in the documentation supplied to Purchaser.

Any software action that may impact the traffic shall be access-limited by passwords. Any software reset shall not impact the traffic nor corrupt the already collected information.

Any software modification shall be password-protected.

All necessary software upgrades to conform to the Technical Specification shall be thoroughly tested and documented, in an environment representative of the System, prior to its installation in the field. Such information would be duly conveyed to Purchaser for review. Further, the Contractor must provide proven detailed procedures for accomplishing such installation in the field. Should such installation occur after the PA of the system, the impact on Purchaser traffic shall be minimized.

The time frame for these upgrades will be mutually agreed between the Contractor and Purchaser and will depend on the nature of the deficiency or of any new features that may be requested by Purchaser.

Retrieval of the previous information in the database shall be possible. Software upgrades will be previously tested at factory if requested by Purchaser. They shall be fully documented and unambiguously identified. Unless agreed in writing, new releases shall not alter the applications or the uses of the System or parts thereof, whether or not in conjunction with existing files.

At the request of Purchaser, the Contractor shall provide quotations for new technical requirements.

All the QA requirements of this specification fully apply to the software.

6.6 Submarine System Power Feed Equipment

6.6.1 Scope

The Power Feeding Equipment (PFE) shall comprise the equipment for converting the terminal station power supply into the form required to energize the submersible plant. Means shall be provided to interconnect the power feeding cable, the optical fiber transmission cables, and the submarine cable.

The PFE shall be powered at each Cable Shore Stations from standard commercial AC power sources.

The power factor of the load presented by the Network Infrastructure shall be 0.90 or greater.

The PFE shall incorporate protection against transient overvoltage at the supply input.

The Contractor shall provide the following design requirements at PDR and CDR for the following parameters:

- Nominal operating current and operating limits
- Output maximum voltage
- Output maximum limited voltage
- Output voltage long term stability
- Regulations/load characteristics
- Output current stability
- PFE reconfiguration time between normal and zero voltage and vice-versa
- Electroding performance
- Output voltage ripple
- Input surge current from PFE switch on
- Maximum voltage between Return Earth and Station Earth

6.6.2 Redundancy

The PFE System of the Shore Station shall have sufficient redundancy such that the System complies with the requirements of System availability.

Indication shall be provided on the equipment and Management Sub-system to clearly show which part of the equipment is working and which part is on standby or off line.

6.6.3 Construction

6.6.3.1 Design

The power for feeding the submersible plant shall be derived from the station's three

RSN Technical Specifications

phase 480 volt power supply by means of solid-state devices.

6.6.3.2 Dimensions

The PFE shall be as small as practicable within the design and safety requirements of this Specification. In any case they shall be such as to pass through standard apparatus double room doors 2.0 m x 1.2 m wide. The weight of a unit shall not prohibit normal handling methods during installation.

6.6.3.3 Cable Power Indicator

A device shall be permanently connected to indicate the presence of power on the submarine cable at the cable terminating unit. The indication shall be visible from the outside of the equipment at the point of access into the cable terminating unit.

6.6.3.4 Suite Formation

The racks shall be assembled to form a suite. The design of the suite shall exclude side entries for both maintenance purposes and external cabling.

6.6.3.5 Mounting of Components

Particular precautions shall be taken to physically secure all components used in the equipment to prevent them from vibrating free. The PFE shall comply with all shock, vibration and earthquake standards required by the local building codes.

6.6.3.6 Fire Protection and Accesses

The PFE shall minimize the use of flammable materials, the use of which is subjected to authorization by Purchaser, and permit, in the event of fire, fast access to all PFE bays through an emergency procedure without performing all equipment operating procedures. The PFE shall comply with all local fire codes.

6.6.3.7 Plug-in Units

To the greatest extent reasonably practical, plug-in units or sub-assemblies that perform the same functions shall be identical and interchangeable physically and electrically, excluding any setting up adjustments or DWDM wavelength specific equipment.

6.6.3.8 Power Feed Cable

The high voltage cable between the beach joint and the PFE shall be constructed so as not to create an electrical safety hazard to personnel.

Precautions shall be taken to prevent static charges or conduction of cable power through

RSN Technical Specifications

contaminant films or similar mechanisms from creating an electrical safety hazard in the fiber interconnection area.

6.6.3.9 6.6.3.9 Other Cables

The Contractor shall provide all the necessary cabling between the PFE and the other parts of the Terminal Station.

Precautions shall be taken to prevent any hazard due to the proximity of high voltage equipment.

6.6.3.10 Cable Terminating Unit

The cable terminating unit shall comprise an enclosed unit that shall be mounted inside the PFE or externally. If mounted on the floor it will be provided in racking of the same type as used for the PFE.

The cable terminating unit shall provide the mechanical and electrical means of terminating the submarine cable. The submarine cable shall be fixed permanently and facilities shall be provided to isolate the cable for testing, without disturbing permanent cabling, wiring or fibers. A safe means for temporarily earthing the cable while preparing this isolation shall be provided. A safe means for temporarily isolating the cable from the PFE shall be provided.

Each electrical conductor assembly in the submarine cable shall be separately terminated in the cable terminating unit and the conductors shall be insulated from each other to the maximum design output voltage of the equipment.

The earth connection in the cable terminating unit shall be provided by a dedicated cable connected directly to the station earth.

Any earth/screen conductor in the submarine cable shall be connected to the station earth in the cable terminating unit or equivalent System a normally high impedance device arranged to conduct when an unsafe voltage occurs across its terminals.

6.6.3.11 System Protection

The PFE design shall ensure that, for every possible PFE configuration and taking into account earth potential differences, the PFE and the submersible plant shall be fully protected in the following events:

- Cable fault anywhere in the System
- To the greatest extent reasonably practical, lightning strike or any other natural phenomena at or close to any Terminal Station
- Voltage out of limits between power feed earth and station earth system

RSN Technical Specifications

6.6.4 Design Life and Reliability

The design life of the PFE shall be 25 years with the exception of a COTS computer that may not be designed for the entire lifetime. The reliability of the PFE shall be consistent with the reliability of the System and end-to-end performance.

6.6.5 Protection of Personnel

6.6.5.1 Interlocks

The equipment shall be interlocked to prevent personnel gaining access to dangerous potentials. The interlocks shall allow access to the cable head areas of the cable terminating unit only when the equipment is de-powered.

6.6.5.2 Emergency Shut Down

The equipment shall include a facility with remote extension in the same station by which the PFE may be de-energized by any staff shall a safety hazard exist. This facility shall be distinctively marked and shall be provided on the front and, if accessible, on the rear of the equipment at suitable strategic positions. The design shall pay special attention to ways of preventing the facility being operated inadvertently.

The PFE Emergency shutdown shall also be operable from a remote position in the Terminal Station.

6.6.5.3 Earthing Devices

The equipment shall include an adequately insulated device to enable potentially high voltage points, in particular the power conductor feeding the submarine cable, to be discharged to earth before handling.

6.6.5.4 Operation and Maintenance

Appropriate warning notices shall be fitted at all places where dangerous voltages exist.

Plug-in units for sub-assemblies taken out of service for maintenance purposes shall be safe for handling and testing by station staff.

The design of the equipment shall ensure that high voltage circuits are automatically discharged when the equipment is de-energized. At least 2 levels of safety shall be provided against each hazard in case one level fails or is inadvertently over-ridden. Trips and/or earthing devices shall be provided on all access doors/panels. Warning Signs DO NOT count as one level of protection.

RSN Technical Specifications

6.6.5.5 Safety of personnel repairing the cable

The power feeding arrangement and powering procedures shall be such as to ensure the safety of personnel operating on the cable during a repair. Interlocks to insure power has been shut down shall be provided to prevent attempting a submarine cable repair with power on.

Contractor shall comply with the appropriate specifications and safety regulations.

6.6.6 Protection of the Submarine System

6.6.6.1 Surge

To the greatest extent reasonably practical 1) the design shall ensure that no hazardous current or voltage is applied to the cable segments at any time either during normal operating conditions or under fault conditions arising from faults external or internal to the equipment and 2) the design shall ensure the equipment itself and the submersible plant are protected in the event of a lightning strike or any other natural phenomena e.g. magnetic storms, at or adjacent to any terminal or any power surge which may result from a cable fault anywhere on the System when the PFE is feeding its maximum output, except for extraordinary circumstances.

6.6.6.2 Voltage Limiting

The output voltage from all PFE equipment shall be inherently restricted to a maximum value. The limiting action shall not rely on alarm devices.

6.6.6.3 Output Current Control

The system shall have current limiting to protect the PFE and to protect the cable from current greater than the 10 amp rating for the repeaters.

6.6.7 Powering of the Submarine System

6.6.7.1 Powering Configurations

It shall be possible to indicate to the PFE in each site the powering configuration chosen for powering the submarine cable.

The system specific powering configuration shall contain the information and instructions related to the particular system being powered taking into consideration the system topology.

The powering configuration shall include voltages, currents, ramping procedures and limits for the PFE to use.

RSN Technical Specifications

6.6.7.2 Powering Up

The design shall incorporate a closely controlled powering up sequence for energizing the submersible plant. The Contractor shall provide documentation on the powering up of the System. The documentation shall include scenarios with cable faults in each of the segments defined by the location of Cable Shore Stations. The documentation shall be reviewed and accepted by Purchaser. The Procedure must be supported by technical analysis, possibly including numerical/computer simulation. The procedure must be such that the probability of a powering incident such as achieving the wrong configuration or achieving instability is reduced to a minimum.

The method employed for energizing the submersible plant shall not cause power surges sufficient to damage the submersible plant or significantly reduce the life of one of its components.

6.6.7.3 Powering Down

The design shall incorporate a closely controlled powering down sequence for de-energizing the submersible plant. The Contractor shall provide documentation on the powering down of the System. The documentation shall include scenarios with cable faults in each of the segments defined by the location of terminal stations and Branching Units. The documentation shall be reviewed and accepted by Purchaser. The Procedure must be supported by technical analysis, possibly including numerical/computer simulation. The procedure must be such that the probability of a powering incident such as achieving the wrong configuration or achieving instability is reduced to a minimum.

The method employed for de-energizing the submersible plant shall not cause power surges sufficient to damage the submersible plant or significantly reduce the Life of one of its components.

6.6.8 Management, Monitoring and Alarms

6.6.8.1 Management Interfaces

The Contractor shall describe the PFE management interfaces. Those interfaces shall be standard and use standard protocols (e.g. Ethernet, RS-232). Some redundancy shall be provided in order to be able to maintain equipment management in failure conditions, such as cable failures, station LAN failures, etc... Backdoor access through a modem connected to a POTS line shall be provided.

6.6.8.2 Unit Removal Detection

To the greatest extent reasonably practical, card and/or sub-assemblies (e.g. converters) removal shall be alarmed whenever possible.

RSN Technical Specifications

6.6.8.3 Monitor and Alarm Unit

The equipment shall contain units to monitor the operation and performance of the equipment as a whole and of its units and to initiate station alarms as necessary.

All non-tripping alarms shall be capable of being tested with the PFE in service and without disturbing the System. All tripping alarms shall be testable on the off-line redundant equipment using the dummy load.

6.6.8.4 Alarms

The Contractor shall specify all alarm facilities provided by the equipment and what action each alarm initiates.

All PFE alarms and performance information shall be passed to the MTE. The MTE shall record and display all abnormal events (e.g. voltage and/or current fluctuations etc.) on a continuous basis when they occur.

6.6.8.5 Alarms List

As a minimum the following alarms shall be transmitted to the MTE:

- a) PFE shut down (autonomous or manually activated, specified by alarm)
- b) Converter Shutdown (High Voltage / Current, Low Current)
- c) System Earth Fault
- d) Ocean Ground Protector Active
- e) Converter Fault
- f) Power Stage Fault
- f) Low Line Current
- h) High Line Current
- i) Low Line Voltage
- j) High Line Voltage
- k) Communication Failure
- l) Low Input voltage
- m) Fan Failure

6.6.8.6 Tripping Alarms

Tripping alarms shall be provided which will shut the equipment down to prevent any hazardous conditions being applied to the System.

RSN Technical Specifications

6.6.8.7 Alarms Severity

PFE alarms are preprogrammed. Shutdown alarms have a severity of Major, and all other alarms have a severity of Minor.

The PFE Alarm Severity list shall be reviewed by and agreed by Purchaser before the beginning of PFE manufacturing.

6.6.8.8 Re-setting of Alarms

Minor alarms automatically clear when alarm condition is no longer present, major alarms latch and require manual reset.

6.6.8.9 Failure of Alarm Circuit

This section has been intentionally left blank.

6.6.8.10 Alarm Display after Shut Down

The alarm system shall be arranged so that the alarm conditions resulting from a fault are readily apparent after the PFE has shut down.

6.6.8.11 Un-powered Alarm Unit

The PFE, when the alarm unit is not powered, shuts down or maintains current regulation and will shut down if a 10 % over-current is reached.

6.6.8.12 PFE Performance Information and Performance Alarms

At least the following PFE performance information shall be monitored:

- a. Line voltage and current
- b. Output voltage and current of each power unit
- c. Current in conductor of the power feed ground cable
- d. Voltage difference between station ground and power feed ground
- e. Current flow in the station ground system
- f. Station input voltages
- g. Station input currents
- h. Temperature of critical components inside the PFE

The PFE alarm conditions that will cause equipment shutdown shall include, but not be limited to the following:

In the individual power converter equipment:

RSN Technical Specifications

- a) Over current
- b) Converter failure

In the common power path:

- c) Over voltage
- d) Over current
- e) Lack of current
- f) Battery voltage out of limits if batteries provided in PFE

Alarm conditions that do not necessitate equipment shutdown shall be indicated as required to enable appropriate remedial action to be taken. These alarms shall include, but not be limited to, the following:

- a) Voltage out-of-limit
- b) Current out-of-limit

Adjustable Thresholds with Defaults

Alarms that relate to quantitative parameters shall have thresholds clearly indicated by the Management System. There shall be a default threshold for each one.

When appropriate, it shall be possible to provision the thresholds to non-default values. The management system, through the GUI, shall tag the non-default thresholds (e.g. use a different font type or color)

6.6.8.13 System Performance

Under all operating conditions the alarms and monitors shall be sufficient to prevent a PFE fault affecting the long term performance of the submerged plant and to protect the PFE against further damage shall any component becomes faulty.

6.6.8.14 Meters

The equipment shall incorporate metering devices to indicate voltages, currents and other relevant parameters at principal points in the equipment, typically the output of each power unit and the output to the line.

- a) Meters shall be located on the front of the equipment at working height.
- b) Meters fitted in high voltage sections of the circuit shall be fitted with external shunt resistors and static free glass. If fitting of such glass affects the ability to read the meter, then meter illumination shall be provided.

RSN Technical Specifications

- c) The accuracy of all meters provided shall be commensurate with the voltage and current tolerances required by the System, typically 0.1% on currents and 1% on voltage.
- d) It shall be possible for these parameters (metered outputs) to be accessible externally to the PFE for monitoring by test equipment. These external accesses shall be electrically isolated from the PFE High Voltage and PFE ground.

6.6.8.15 High Speed Transients recording:

The Contractor shall indicate the frequency response of these external monitoring connections in order to facilitate transient recording.

6.6.8.16 Remote Monitoring

Remote monitoring of the PFE must be provided. All the alarms and monitored parameters must be made available to the Management sub-system. Monitored parameters must be recorded as historical data to be archived.

6.6.8.17 Remote Control

For Safety reasons, remote control of the PFE is not supported, however remote monitoring is supported.

6.6.9 Earth Connections

The PFE shall be capable of being interconnected to two “earths” as follows:

- a) Ocean Ground Bed to form part of the circuit for powering the submersible plant. The PFE's shall be capable of working with earth potentials of up to +25V with reference to Station Earth.
- b) The overall Cable Shore Station “Station Earth”

The PFE shall limit the voltage difference between the Ocean Ground Bed and the Station Earth to safe levels.

Protective devices shall be provided to route the return current to the Station Earth automatically if the Ocean Ground Bed electrode becomes disconnected, or changes to a potential difference from the Station Earth. The operation of the device shall not cause interruption or permanent interference to the system or permit rises in power equipment earth potential sufficient to damage the equipment or endanger personnel. A monitor shall be provided to indicate any current fed to Station Earth. Audible and visual alarms shall be given on operation of the device.

RSN Technical Specifications

Provision shall be made for routing all the power-feed current to the Station Earth and isolating the Ocean Ground Bed, using lockable switches; so that work may be carried out on the Ocean Ground Bed without interrupting traffic. It shall be possible for the Ocean Ground Bed to be disconnected with complete safety.

In the case where the Ocean Ground Bed is common to other submarine cable systems the Contractor shall explain how he will ensure that the new connection does not affect the general performance of the power feed earth system of the other submarine cable systems, mainly in terms of electromagnetic interference and protection against voltage surges.

6.6.10 Ocean Ground Bed Electrodes System

The Ocean Ground Bed shall utilize a deep anode bed with an impedance of less than 2.5 ohms. For maintenance purpose, the electrodes shall be brought inside the earth cabinet in the station in two groups.

If the Ocean Ground Bed is located in water, it shall be sited below the lowest low tide level but accessible by divers for maintenance.

The Ocean Ground Bed earth cables shall be screened and auxiliary earth shall be made available to optionally connect the screen at each extremity and intermediate joints.

6.6.11 Dummy Load

The Contractor will list as an option, equipment that shall include a dummy load simulating part of the submersible plant and shall be capable of connection to any single power unit not supplying current to Line without interference to the System.

When the PFE is out of service, the dummy load may be connected to the entire PFE.

The Dummy Load power dissipation characteristics must be consistent with the installed PFE in the cable station where it is located. The maximum power dissipation of the Dummy Load shall be at least 20 kW.

The Dummy Load must be monitored and alarmed with the same requirements that apply to the PFE.

Thermal Shutdown: the Dummy load shall incorporate an automatic thermal shutdown mechanism to prevent accidental overheating. It shall be alarmed.

6.6.12 Cable Electroding

The PFE shall include a high-stability oscillator that is capable of modulating the line

RSN Technical Specifications

current to enable in-service cable electroding to be used by ships (surface electroding), submersibles and divers (hand-held detectors). The oscillator frequency shall be 25 Hz +/- 1%.

The level of modulation shall be adjustable and the maximum level shall be as high as possible without adversely affecting the performance of the System. Higher modulation level shall be possible for out of service electroding.

The PFE shall also include a facility for injecting out of service an external electroding signal in the range 4 to 50 Hz.

6.6.13 PFE Performance

6.6.13.1 Regulation

The equipment shall provide a regulated supply such that the overall stability requirements of the System can be met.

The regulation method shall tolerate:

- a) Variation of power supply voltages and any transients such as those produced when switching to the station battery due to failure of the primary power supply
- b) Ambient temperature changes within the operating range
- c) Variation of magnetically induced voltage (e.g. magnetic storms)

6.6.13.2 Current Surges

The equipment shall be designed such that a current surge caused by a short circuit anywhere in the system, while the equipment is feeding its maximum design voltage, is not sufficient to damage any component of the System.

6.6.13.3 Output Voltage

The output voltage of the equipment shall automatically adjust to maintain the normal line current in the presence of naturally induced voltages.

6.6.13.4 Ingress of Dust

The equipment shall be designed to minimize the effect of dust on the performance of the equipment. Unless the ingress of dust can be entirely prevented all high voltage parts shall be suitably protected.

If air filters are used, they must be clearly specified and a procedure must be provided defining the maintenance method, frequency of cleaning and/or replacement.

RSN Technical Specifications

6.6.14 Security of Service

6.6.14.1 Manual Control

Any power unit shall be capable of being switched manually into circuit to replace any other unit(s) without interrupting traffic.

6.6.14.2 Parallel Current Paths

All the less reliable components in the high voltage output power circuit, e.g. meters, shall be provided with parallel current paths or other means to assure reliability of the system.

7 Assembly, Loading and Laying Of the Submersible Plant

7.1 General

The Contractor shall be totally responsible for stowage of the submersible plant, its safe passage to the laying sites and satisfactory installation on the seabed. This responsibility shall extend to all vessels employed on the work.

The Contractor shall verify that all redundant components operate satisfactorily during the overall submersible plant tests performed after loading on board the laying ship and during the laying operation. Any failure of a redundant component occurring prior to or during laying, and detected in the submersible plant on board the cable laying ship, in the cable section being laid or in the preceding cable section shall be cleared. If detection during laying is not feasible any failure of the redundant component detected in any cable section after laying shall be cleared.

7.2 Assembly of the Submersible Plant

The Contractor shall provide full details of the method it proposes for assembling the submersible system. In particular, it shall provide:

- a) A schedule of the assembly program
- b) Test specifications and acceptance criteria for each stage of assembly, namely:
 - On each cable section prior to jointing
 - On each repeater/Equalizer/BU (if applicable), Primary Node prior to jointing
 - On each Segment during jointing; particularly it shall indicate the method used for monitoring the optical parameters of each repeater section of the System
 - On each shipload prior to loading
- c) Details of the method to protect the repeaters/equalizers/BUs (if applicable) during loading and laying
- d) Details of safety procedures to be used, particularly when the system is powered

Purchaser Representatives may be present during all test periods and shall have full access to test results.

RSN Technical Specifications

7.3 Jointing

7.3.1 Jointers' Qualification

All jointing operations carried out by the Contractor shall use fully qualified jointers. Proof of jointer's qualifications shall be given by the Contractor at the time of submission of System Loading and Laying Instructions (SLLI) except for shipboard jointers whose proof qualification must be submitted prior to the cable loading.

7.3.2 Supervision and Jointing Operations

The Contractor shall appoint a supervisor who shall be responsible for the supervision of its jointers. The Contractor shall supply testing officers to cover all aspects of joint evaluation and testing.

7.3.3 Jointing Specifications

The jointing of cable shall be carried out in accordance with approved specifications. Copies shall be included in the SLLI.

7.3.4 Completion of Shipboard Testing

To the greatest extent reasonably practical, testing of all individual cable sections shall be completed prior to marine installation.

7.4 Loading and Laying Of the Submersible Plant

7.4.1 General

The Contractor shall appoint a senior representative during all operations within the scope of this Paragraph who shall be in overall charge of the Contractor staff and shall be available at all times when work is in progress.

The Contractor shall give details of the proposed management structure during all operations within the scope of this Paragraph. The responsibilities of all Contractors' staff shall be included in the Contractor Installation Plan.

The Contractor shall provide audit access to a fully controlled procedures manual for the operations listed in his Installation Plan, paying particular attention to the procedures for the deployment, recovery and emergency abandonment of all towed and tethered equipment.

The following Sub-Paragraphs are applicable to the loading and laying of the main cable using an adequately equipped cable laying vessel. In the case where the laying of shore end cable section is carried out by a converted small vessel or a barge, sufficient details

RSN Technical Specifications

regarding the vessel's maneuverability, the positioning equipment on board and other additional information as specified shall be given by the Contractor.

7.4.2 Cable Ship Requirements

The submarine cable, Primary Nodes and all required repeaters/equalizers/BUs shall be laid by a cable laying ship owned or chartered by the Contractor subject to the approval and audit of Purchaser under the conditions specified hereafter.

The cable laying ship proposed by the Contractor shall be suitably equipped for the laying of submarine cable according to procedures commonly in use at the date of laying and the crew of this ship shall be accustomed to such operations.

The Contractor shall provide a detailed description of the ship and of its equipment and references.

The laying ship shall be adequately equipped and shall conform to the following requirements:

- a) Ship's cable engine drums, sheaves, tank cones and cable leads to conform to the minimum bending radius recommended in the relevant cable specifications. The construction of the ship's cable tanks shall be such that cable stowed therein does not suffer damage during passage
- b) Ship shall be equipped with a cable engine aft capable of handling the selected cable types and repeaters, equalizers, BU's (if applicable), Primary Nodes and any other types of submerged plant to be installed at reasonable pay out speeds. Accurate dynamometers fore and aft shall be provided and the record of calibration procedures and documentation shall be kept, although in the case of stern-only working ships, only aft dynamometers will be available.
- c) Ship to be adequately staffed to allow all planned work to be carried out as a continuous 24 hours/day operation
- d) Ship to be adequately equipped with all necessary tools for cable installation and repair operations, e.g.: ropes, buoys, stoppers, grapnels, jointing, splicing and test equipment
- e) Ship to have suitable accommodation of suitable size, environment and accessibility for the proper performance of transmission tests, equipment testing, optical cable jointing as necessary
- f) Ship's navigation equipment must be of the highest standard and duplicated where appropriate for reliability. The ship's navigation equipment shall include at least the following:

RSN Technical Specifications

- a. Duplicated Global Positioning System Satellite navigator
 - b. Duplicated Differential Global Positioning System Satellite navigator
 - c. Gyro compass
 - d. Radar
- g) On shelves and slopes an accuracy of +/- 10 meters is required and outside the range of coastal based positioning systems, an integrated satellite positioning system shall be used on a 24 hour basis comprising satellite receiver with GPS and DGPS options interfaced to the cable ship gyroscope and speed log. The GPS satellite system shall be the primary means of navigation to be used
- h) Ship to have echo-sounding equipment capable of producing a continuous sounding profile over the entire route
- i) Ship to have adequate radio and maritime satellite communication facilities so that communication can be maintained with terminal station(s). Fax equipment is to be made available
- j) Ship's complement may include a doctor or medical trained staff who may be part of the ship's crew to minimize the risk of operations being suspended for landing sick personnel
- k) Ship to be highly maneuverable and large enough to work in adverse weather conditions
- l) The ship shall be equipped with a suitable dynamic positioning system
- m) Ship to have adequate endurance (i.e. fuel, water and stores) to carry out all cable operations and passages however, the decision of the ship master is final in determining safe and practical conditions in which to work
- n) Ship to have adequate equipment able to reproduce documents. This facility shall be provided free of charge to Purchaser Representatives
- o) In addition to the Contractor personnel, accommodation shall be available for up to 2 representatives of Purchaser. Accommodation and sustenance shall be provided on board the cable laying ship for them for the entire duration of the lay at no extra charge. In the event that special dietary requirements are requested by Purchaser representatives, this requirement shall be made known to the Contractor one month before the laying works and shall be provided at no extra charge subject to availability.
- p) The Contractor shall provide notice to Purchaser of operational timings as soon as is practicable to facilitate the attendance of Purchaser representatives

RSN Technical Specifications

7.4.3 Other Requirements

Each Purchaser Representative shall be entitled to two free daily telephone and facsimile communication per satellite, or cable if available. In cases of emergency or in critical situations, unlimited communications facilities shall be granted.

In case of multiple Purchaser Representatives, they will nominate among them a Senior Purchaser Representative, who will be the official point of contact for the Contractor during the marine operations.

Communication facilities internal to the ship shall be provided by agreement with the Senior Purchaser Representative. This will normally consist of a cabin telephone extension and a facility to monitor operations communication channels.

Office facilities shall be provided for use of the Senior Purchaser Representative comprising desk space, document storage and facilities to allow operation of a personal computer and printer in conditions where confidentiality of work in progress can be maintained.

Facilities to allow work to be carried out on fully spread survey charts shall be provided for use by Purchaser Representatives.

7.4.4 Information to be provided by the Contractor

The Contractor shall provide the following information:

- a) The type of typical cable ship it proposes to use for the operation
- b) Types of all navigation aids on board including echo sounding equipment, depth chart recorders (including paper speed indication) and radar
- c) Types of machinery provided for the laying and recovery of cables, Primary Nodes and repeaters/equalizers/BUs
- d) Types of test equipment on board for the electrical and optical tests of cables and repeaters, BUs, and Primary Nodes including jointing equipment and procedures, test equipment and proposed testing procedures for checking the integrity of all joints
- e) Description of methods employed for the laying of all submersible plant
- f) Description of the methods to control the temperature of the repeater, equalizer and BU stacks (if applicable)
- g) Details of similar operations previously carried out by the Contractor.

RSN Technical Specifications

In case the Contractor wants to change the cable ship during the course of the Contract, the Contractor shall not offer a cable ship with lower performance than the one offered in the contract. The Contractor shall seek for Purchaser approval of such a change.

7.4.5 Equipment to be provided by the Contractor on Board of the Laying Ship

The Contractor shall be responsible for the provision and installation on board the cable laying ship of all the equipment required for making cable joints, terminations, as appropriate, electrical power feeding of repeaters, equalizers, BU's (if applicable) and Primary Nodes and undertaking on board tests. The supply and installation on board the cable ship of any burial system shall be the responsibility of the Contractor.

7.4.6 Loading and Laying Procedures

The Contractor shall submit documentation detailing its normal loading and laying procedures and a detailed schedule of the loading and laying operations. The Contractor shall make available such procedures on board the installation vessel for the use of Purchaser.

7.4.7 Auxiliary Facilities

The Contractor shall describe all the auxiliary facilities and support craft, which are necessary to lay and bury the cable, including pre-laid shore ends (where applicable) as well as the facilities, which will be used, on land for the laying of the shore end cable.

7.4.8 Damage during Loading and Transit

The Contractor shall ensure that any equipment and loading techniques do not damage or cause deterioration to the submersible plant. Shall any part of the submerged plant be damaged or subjected to excessive shock, strain or bending the Contractor shall stop the load immediately and notify Purchaser. When either the submersible plant sustains damage or is subjected to forces which may cause deterioration at a future date, the Contractor shall agree with Purchaser on the remedial action to be taken.

The Contractor shall be responsible for rectification of any damage sustained by the submersible plant during transit between the points of departure from the manufacturing site to the place of final installation irrespective of the cause.

7.4.9 Damage during Laying

The Contractor shall be responsible for the satisfactory installation of the submersible plant on the seabed. The Contractor shall ensure that any equipment and laying techniques do not damage or cause deterioration of the submersible plant or do not cause delay

RSN Technical Specifications

during the installation. Shall any plant be damaged or subject to excessive stress, strain or bending, the Contractor shall immediately notify Purchaser and agree with Purchaser on the remedial action to be taken.

In the event of a submersible component being physically damaged or fails mechanically during the laying operations, the Contractor shall replace the unit with an on-board spare.

In the event of any cable damage during shore end laying operations, due to the fault or negligence of the Contractor, there shall be no repair joints within 3 km from the beach manhole).

7.4.10 Security during Laying

The Contractor shall be responsible for the satisfactory physical security of the personnel and submersible plant aboard the installation ships. The Contractor shall ensure that appropriate precautions are taken to protect against the threat of piracy or any other such terrorist activity. The Contractor Physical Security Plan shall be subject to review by Purchaser.

7.5 Testing During Loading

7.5.1 Tests

The Contractor shall be responsible for all testing during loading, the provision of testing, power feeding and associated equipment, as described in the SLLI.

Following the loading of a designated number of sections, the System shall be tested in accordance with the SLLI. On detection of a fault, loading shall cease until remedial action has been agreed with Purchaser. Overall System testing shall be in accordance with the SLLI.

7.5.2 Test Results

The results of the tests above shall be handed to Purchaser for evaluation. The Contractor shall discuss and agree to the interpretation of the results with Purchaser. Any dispute concerning the interpretation of the test results shall be resolved before sailing.

7.5.3 Purchaser Tests

The Contractor shall, work with the Purchaser to obtain sufficient test data for fault location during the factory system testing. These tests shall be subject to discussion and agreement between the Contractor and Purchaser and will be phased, as far as possible, to cause minimum delay. The Contractor shall specify the safe testing limits and shall have the right to observe the procedures used and state his objections to Purchaser at any stage at which he considers that the tests could affect the overall System performance.

RSN Technical Specifications

7.5.4 Testing During Laying Operation

The System shall normally be powered at specific times for testing purposes during laying subject to safe working practices. The Contractor shall indicate when it intends to power the cable system during the laying operation.

The Contractor shall be responsible for all electrical, optical and transmission tests during the laying operation(s) and the provision of testing, power feeding and associated equipment and the interpretation of test results. The Contractor shall allow to Purchaser full access to all operations during cable laying, as well as test results, and any other information on which the Contractor is basing its decisions. The Contractor may also seek the co-operation or opinion of Purchaser on any matter relevant to the operation. In addition, Purchaser shall have the right to comment to the Contractor on any matter relevant to the operation.

7.6 Cable Route Clearance Operations

7.6.1 General

The use of burial tools to enhance the security of the submersible plant requires the seabed along the agreed route to be cleared of all surface and sub-surface artificial obstructions.

7.6.2 Objectives

The objective of this activity is to ensure that, as far as reasonable endeavors, the agreed route is clear and free from known out-of-service submarine cables in such a manner that installation and subsequent maintenance operations are not hindered by the presence of such hazards.

It is intended that, at the conclusion of this activity, the route will be, as far as possible:

- Clear of out-of-service submarine cable systems
- Declared safe for a cable laying and burial within the confines of the cleared route

7.6.3 Activities

Whenever out-of-service submarine cables are located/detected, they shall be recovered to ensure that a safe corridor is cleared on either side of the selected route as per Table 3 below:

Water Depth (m)	Target Corridor Width (m)
000-025	As required
026-200	200
201-500	500
501-750	750

RSN Technical Specifications

751-1000	1000
----------	------

Table 3 – Out-of-Service Cables, Target Recovery Corridor Width

In congested waters it may not be feasible to clear the target corridor width or to grapple either side of the route and reasonable endeavors shall be made to clear a workable corridor.

Prior to any cutting or clearance of OOS cables, permission to cut and clear the existing cable shall be provided by the owner of the OOS cable. Purchaser will obtain authorization from the last known owners of the OOS cables for their clearance. If permission is not granted the OOS cable will be treated as an active cable. Should additional cables go out of service after the completion of route clearance operations, Contractor can discuss with Purchaser options for cable crossings or additional route clearance operations.

The cable ends remaining shall be re-laid on the flat sea bed in accordance with ICPC recommendations in such a manner that they do not cause future liability to Purchaser from third parties or problems to other sea bed users. The Contractor shall advise the method to be used for re-laying the cable ends which shall be subject to the agreement of Purchaser Representative.

In the event that charted out-of-service cable systems are not located/detected, the route clearance tools shall be pulled through the seabed to ensure that a safe corridor, A maximum of 5 grapnel runs will be made, these will be at 50 & 100 meters either side of the crossing with a final clearance drive along the route centerline by a grapnel with a penetration depth greater than the target burial depth.

In the event that out-of-service submarine cable system are charted as being within 1500 meters of the selected route, but not crossing, the area shall be proved as above to ensure that the out-of-service submarine cables are not present.

Whenever other seabed debris is encountered, this shall, as far as practical, be cleared.

All cable and materials recovered during the operations shall be stowed on board the vessel for disposal ashore in accordance with applicable legislation.

The Route Clearance shall be undertaken for the portion where the plow is intended to be deployed.

In all circumstances, no towed equipment shall be used within 500 meters of any pipeline or in-service submarine cable system.

RSN Technical Specifications

7.7 Cable Burying

7.7.1 Pre-Lay Grapnel Run

The success of the burial operation is dependent upon the removal of all obstructions and debris from the route. The pre-lay grapnel run shall immediately precede the plow burial operation and is intended to ensure clearance of any debris, etc. not cleared during the route clearance operations, or deposited/jettisoned since. The operation includes the towing of a grapnel along the centerline of the route to be plowed. Contractor will make reasonable endeavors to clear the seabed of debris which may have been deposited along the route and the debris will be discharged ashore upon completion of the operations.

7.7.2 Burial by Plow

The Contractor shall provide details of the proposed burial method that shall at least include the method of controlling, indicating and recording the thickness of the cover over the cable and position of cable entering the seabed at any point along the route. These details shall be subject to inspection and approval by Purchaser Representative which approval shall not be unreasonably withheld.

The Contractor shall submit a detailed description of how the laying cable ship will cope with external forces due to weather and tidal currents. In particular, the Contractor shall provide details of any other vessels which may be required during the burial operations, such as tugs, guard ships, etc...

In the sections of the route which were agreed to bury, the cable shall be buried nominally to 1.3 meter \pm 0.2 meter with a target of 1.3 meter, on a reasonable endeavors basis that is defined as the following:

If the maximum tow tension of 40 tonnes is reached and the plough speed falls below 600 m/hr., then the plough share depth will be reduced in 100 mm steps until the minimum speed is restored.

The maximum length of cable buried with cover depth less than 0.5 meter shall not exceed 100 meters in any 20 kilometers or part thereof.

It is a Purchaser requirement to bury repeaters if used, in the sections where cable burial is agreed, by means of the primary burial tool.

The residual cable tension shall be as low as practicable. The Contractor shall state the average and residual cable tension.

Exceptions from this requirement can only be made in places where local spots with hard seabed or stones/rocks prevent the burial equipment from penetrating to the required depth. Such incidents shall immediately be reported to Purchaser Representatives. The geographical positions and the amount of cable not buried shall be clearly noted in the laying log together with a detailed explanation of the incident.

RSN Technical Specifications

The Contractor shall state the minimum water depth for plowing.

7.7.3 Post Lay Burial Operations

The Contractor shall perform a Post-Burial operation in order to bury initial, final or intermediate splices, cable crossings, BU's and any other cable length not possible of being properly buried with the plow.

If during the plow burial some cable lengths are not buried, a Post Lay Burial Operation will be carried out. This requirement includes among others the case of the cable lengths not buried due to failures of the sea plow including its recovery for repair or maintenance or to weather impeachment.

7.7.4 Post Lay Inspection

The Post Lay Inspection is intended to inspect the proper laying and proper burial of the cable in the seabed. This operation shall be carried out along the buried section where burial was recommended to a maximum of 5% of the buried sections. The Contractor shall provide full details of the proposed cable ship and submersible vehicle and procedures for the burial operations inspection together with any operational limitations. The submersible vehicle shall be capable of operating to a depth of 1500 meters in a continuous 24-hour/day operation. Since water depth dictates how the operation will be performed, the work is split as follows:

- Cable Shore Ends to 20m water depth, performed with divers.
- Shallow waters and deep waters performed with a submersible ROV.

A complete report on the inspected areas shall be presented, including video recordings (on DVD).

7.7.5 General Requirements

7.7.5.1 Data Log

During the main lay of the cable, the burial operation of the Contractor shall log the following data:

- a) Time and date
Time (Standard to be agreed with Purchaser Representative) to one (1) second for clarification, this refers to the accuracy of the time clock. Data shall be logged at reasonable intervals according to the installation being undertaken.
- b) Burial Achievement (continuous logging data)
 - Depth of cover over cable
 - Cable back tension (plow)
 - Depressor and arm height (plow)

RSN Technical Specifications

- Tow force (plow)
- Pitch (plow)
- Skid height (plow)
- c) Route
 - Latitude (center of stern)
 - Longitude (center of stern)
 - Ship Kilometer Point (KP) (center of stern)
 - Latitude (plow)
 - Longitude (plow)
 - Plow KP
 - Deviation from agreed route
 - Navigational accuracy
- d) Cable
 - Laying counter measurement (connected to stern)
 - Shipboard cable tension
- e) Events
 - Cable markers
 - Joints
 - Transitions
 - Repeaters, Equalizers and Primary Nodes
 - Burial equipment maintenance points
 - Alter courses
 - Burial equipment recoveries/launches

The data entries shall be logged against a common clock source and shall be recorded in a suitable software format (e.g. MS Excel). Events shall be recorded to accuracy subject to agreement and the work being undertaken, but as an example may be every 10 meters when plowing and every minute when surface laying and shall be labeled to permit future identification.

7.7.5.2 Repairs/Maintenance

In places where the burial equipment is recovered for repairs/maintenance the geographical positions and the amount of the unburied lengths of the submersible plant shall be clearly noted in the laying log together with a full explanation of the incident.

The amount of submersible plant not buried shall be subjected to further remedial burial by the Contractor.

7.7.5.3 Depth of Burial Indication

The Contractor shall provide a method of controlling and indicating the depth of burial and the position of the cable entering the seabed.

RSN Technical Specifications

7.8 Cable Shore End Inspection

The Contractor shall inspect by video the shore end lay. In the event of kinks, loops or suspensions in the shore end cable the Contractor shall be responsible for their elimination.

7.9 Beach Works

All beach works, provision of machinery and manpower for the realization of cable landing operations and cable splicing, shall be done by the Contractor.

The Contractor shall provide a full description of the methods of burying and recording the position of the cable on the beach.

These methods shall include:

- Installation of adequate cable slack between the low water mark and the beach joint
- Burial and protections
- Recording of the position of the cable

The Contractor shall ensure that the shore end is not exposed above the low water mark at the time of installation and in any event, and that the adequate slack is allowed at all points in the route between the low water mark and the beach manhole. Beach operations are subject to reasonable endeavors and subject to survey.

Subject to the route survey results, if existing in-service or out of service cables are identified, the Purchaser shall provide specialist assistance required for the location and marking of any existing in-service cables present on the same beach. In the event that existing in-service cables or out-of-service cables are not located, then appropriate methods of installation will be discussed with and agreed with Purchaser.

7.10 Pipeline Crossing

Subject to the route survey results, if pipeline crossings are identified, the Contractor shall provide a full description of the methods used for pipeline crossing protection. The Contractor shall take all necessary measures to avoid damaging any pipelines within the area bounded by the System

7.11 Cable Crossing

Subject to the route survey results, if cable crossings are identified, the Contractor shall provide a full description of the methods used for cable crossings and associated protection of such cables. The Contractor shall take all necessary measures to avoid damaging any submarine cables within the area bounded by the System.

RSN Technical Specifications

7.12 Calibration of Equipment

All equipment shall be tested and calibrated to manufacturer's specifications prior to the commencement of operations to ensure proper working order.

8 Terminal Station Equipment Installation

8.1 General

This chapter outlines Purchaser requirements for the installation of the Equipment in each Terminal Station.

8.2 Scope of Work

The Contractor shall be responsible for the installation of all terminal equipment to be provided by it, for all cabling, racking, power supplies and alarm facilities in accordance with the installation requirements issued by Purchaser in the relevant terminal stations.

The Contractor shall supply:

- All necessary racking, cables etc. to interconnect with the station power supplies and the /ODF/Interconnecting equipment
- The HS ODF as appropriate for each terminal station
- The Station Alarm Blocks for each terminal station
- The appropriate furniture for the NMS (e.g. tables, chairs, printer stands, etc)
- Appropriate storage facilities such as racks, etc for all spare and consumable equipment

8.3 General Layout of Stations

A layout plan indicating the typical floor span and height required to install the equipment shall be provided by the Contractor. In addition, sufficient floor space shall be allowed within these areas to permit the subsequent installation of all equipment necessary to fully utilize the System. Floor space for growth of any type of equipment or frame shall be directly adjacent to the equipment or frame.

The equipment shall be installed in such a way that adequate space remains between suites and at the end of suites to enable easy access to all equipment for test equipment, ladders, personnel, etc., for maintenance purposes.

The Layout of the Stations must be accepted by the all the Parties before coming into force.

8.4 In-Station Inspection

After Terminal equipment installation, an inspection will occur between the Contractor and Purchaser and be confined to the soundness of the mechanical structure and workmanship of the installation. A punch-list will derived from the inspection with

RSN Technical Specifications

signatures from both Contractor and Purchaser Representative. An agreed upon resolution of the punch list items will be determined between Contractor and Purchaser will be required, to commence start of Commissioning

8.5 Safety

The Installation shall comply with all national safety regulations and standards of the country where the work is taking place.

8.6 In-Station Testing

After the installation of the Terminal Station Equipment in each terminal station, In-station testing is done to verify that the equipment is still fully functional and did not suffer damage during transit and installation.

8.7 Land Cable Section

In the ducted portion of the land route, the optical land cable, power cable and the return earth cable shall be installed in three sub-ducts of the same duct. In the case of Pacific City, the Purchaser wishes to economize the use of ducts, consolidating the various segments to the extent possible without adversely affecting the performance of the System. Separate conduit for ground cable may be used if the anodes are deep anodes on land instead of wet anodes. The relevant supply, laying, jointing and post installation testing shall be part of the contract.

8.8 Return Earth System

Where provision of the return earth system is required, The Contractor shall lay, joint and test the return earth system.

In the terminal stations where the return earth system is provided by Purchaser, the Contractor shall measure this return earth system prior to the connection of the Transmission Segment.

8.9 Civil Works (Ducts, Man-Hole, Beach Man-Hole)

Purchaser shall provide for the required number of ducts/sub-ducts between the existing beach manhole and the cable station at Pacific City OR. With the exception of the above referenced ducts/sub-ducts, Purchaser shall provide civil works (ducts, man-holes, beach man-hole) where required. The ducts will be clear and Purchaser will provide pull ropes if not installed.

8.10 As-built Drawings

At the end of the Terminal installation, the Contractor shall provide As-built drawings.

9 Acceptance Requirements

9.1 General

The Acceptance Test Program shall include various Test Periods.

Each Testing Period shall comprise such tests necessary to show that all the appropriate parameters, facilities and requirements given in this Specification have been met and to demonstrate confidence in the continuous satisfactory operation of the System throughout its Design Life.

Unless otherwise stated in the present Technical Specification, the Acceptance Tests shall be performed by the Contractor. The Contractor shall permit Purchaser Representatives to observe such tests and to review the test results.

The Contractor shall provide all the necessary staff, materials and testing apparatus to carry out and supervise all the tests. Contractor will utilize the Test Equipment as efficiently possible utilizing such methods as “daisy chains” and “loopbacks

At least one Contractor's engineer shall be present in each terminal station during all the Test Periods. Moreover, at least one Contractor's senior engineer shall be present on-site during Purchaser Test Periods except the Confidence Trials; he shall be responsible for the test program co-ordination and shall provide direct liaison between Purchaser Representatives on-site and the Contractor. In all events where Purchaser representatives are requested to witness any tests, the Contractor shall endeavor to schedule all the test activities so that they do not overlap with each other.

The Contractor shall provide notice to Purchaser at least twenty (20) working days in advance of the starting of the tests, wholly or partly.

The Contractor shall provide a general description of the tests that the Contractor proposes to carry out in order to demonstrate conformance to the requirements of this Technical Specification.

9.2 Provisional Acceptance (PA)

9.2.1 Issuance of System Provisional Acceptance Certificate

The System Provisional Acceptance Certificate will be issued by Purchaser provided that:

- a) The results of the tests of the System Acceptance Test Program included in the System Acceptance Handbook indicate compliance of the System to the Technical Specifications and

RSN Technical Specifications

- b) The Contractor has provided all the deliverable items required by the Contract (except those which do not affect the normal operation and maintenance of the System, if any) and
- c) Nothing has developed that is likely to cause the System to fail to meet the requirements of the Technical Specification or other performance requirements which have been agreed between Purchaser and the Contractor for the twenty five (25) year Design Life.
- d) The Contractor has installed the System in compliance with this specification with a special attention to protection of the submerged plant.

An agreed list of any outstanding items, if any, required by the Contract that do not affect the normal operation and maintenance of the System shall be attached to the Provisional Acceptance Certificate as well as a program to remedy these items.

9.2.2 Certificate of Service

In the event that the System does not meet the above requirements for the issuance of the System Provisional Acceptance Certificate, but the System, wholly or partly, is nevertheless acceptable for use by Purchaser, then Purchaser and the Contractor may agree to issue a Certificate of Service.

A list of the outstanding items shall be attached to the Certificate of Service. The Contractor shall undertake the expected corrective actions accordingly in order to make the System conform to the requirements of the Provisional Acceptance within a time schedule to be agreed upon at that time.

Moreover, in the event that, prior to Provisional Acceptance, the performance of the System deteriorates compared with the performance achieved at the time of Certificate of Service, the Contractor shall be responsible for promptly re-establishing such performance to at least the level of performance at the time of the Certificate of Service.

9.3 System Acceptance Handbook Template

The Contractor shall submit a System Acceptance Handbook Template for the System detailing all the tests to be undertaken and information to be obtained. The Acceptance Handbook Template shall include for each acceptance period a full description of the Acceptance Tests.

This information, including a detailed description of each measurement set-up and the blank copies of the associated test result forms, will be gathered in the Acceptance Handbook Template.

The Acceptance Handbook Template is subject to Purchaser approval and shall be provided as early as possible but not less than three (3) months before the start of the

RSN Technical Specifications

acceptance activity. Purchaser shall make any necessary comments within two (2) calendar months.

As a minimum requirement, the System Acceptance Handbook Template shall include the following:

- a. A detailed description of the Terminal Station Equipment factory and on-site test procedures and blank copies of the associated test result forms
- b. A detailed description of the Submarine Equipment factory, loading and laying test procedures and blank copies of the associated test result forms
- c. A detailed description of the System, including the schematic of the Transmission Segments and all the features required for test or maintenance purposes
- d. A detailed description of the Transmission Segments power feeding test procedures for all the System power configurations and blank copies of the associated test result forms
- e. A detailed proposal for the Overall System Acceptance Test including Purchaser Test Periods, the Contractor's Test Periods, the Out of Service Confidence Trial period with test procedures and blank copies of the associated test result forms
- f. A list of the tests that are to be repeated on the System at the time of Final Acceptance to indicate continued confidence in the performance of the System

On completion of each Test Period the results shall be recorded in the Acceptance Handbook and forwarded to Purchaser for preliminary evaluation.

9.4 Acceptance Test Periods

The Management Terminal Equipment (MTE) sub-system which is going to be installed in the terminal stations shall be used to monitor and record overnight tests during all the test periods, unless otherwise agreed by Purchaser. Additional equipment may be used for test periods if determined to be necessary to exercise the system from the terminal station.

The Acceptance Tests shall consist of nine (9) main test periods:

9.4.1 Period I: Product Design Acceptance Testing

This will apply to any System elements not agreed as being already qualified at the time of Contract placement. It will also apply to any pre-qualified elements undergoing design changes subsequent to Contract placement. The Contractor shall immediately advise Purchaser of any design change to a pre-qualified element.

Product Design Acceptance testing shall provide the means to demonstrate to Purchaser that elements of the System have been qualified to the requirements of this specification. This shall be achieved prior to the acceptance of any such products for System use and preferably prior to commencement of manufacture.

RSN Technical Specifications

Product Design Acceptance shall also include a demonstration of the inter-operation of the SLTE with industry standard Ethernet equipment with a particular attention to the margins at the interfaces and the optimization of the protection mechanisms, if any.

Purchaser shall have the right to audit progress of any of the above aspects at any time during Contract lifetime, on a non-interference basis.

9.4.2 Period II: Factory Acceptance and Submerged Plant Assembly Testing

This test period shall comprise all tests necessary to confirm that the Terminal Station Equipment and submerged plant items are ready for installation and will include factory acceptance tests and submerged plant assembly tests. The tests shall demonstrate that the relevant requirements of this Specification will be met by the full System when installed.

After the completion of the manufacturing of each piece of Terminal Station Equipment, functional and performance tests must be carried out in order to verify that its performance is compliant with the industry standard Ethernet Equipment specifications and compatible with the specifications required for the whole System.

As far as possible, the Terminal Station Equipment configurations shall be identical to its final configuration in the terminal stations (suite, cabling, etc.).

Tests will be performed on all units at their final stage of manufacture in order to verify their compliance with the appropriate technical specifications and their compatibility with the specifications required for the whole System.

Each Segment shall be tested at the time of System assembly to demonstrate parameters consistent with achieving the System performance requirements. The parameters shall be recorded on each fiber span during System assembly.

Contractor shall invite Purchaser to witness Factory Acceptance testing of each first product of each type. If one product is manufactured by several sub-contractors, the invitation shall apply for each first product of each sub-contractor. For the subsequent products e.g. #2, #3 etc... Contractor shall provide Factory Acceptance test results to Purchaser for review and approval.

9.4.3 Period III.A: Terminal Equipment In-Station Testing

9.4.3.1 Suite tests

Following the installation of the equipment in the station, it shall be tested by the Contractor in readiness for acceptance by Purchaser.

A program for in-station testing shall be proposed by the Contractor, such program to be based on the factory suite tests of all terminal equipment and tests on any items not included within the suite tests and shall be performed in accordance with the relevant performance test specifications and the results obtained shall be compared with the tests

RSN Technical Specifications

made in the factory. In the event of an unfavorable comparison between the two sets of results the cause of the irregularity(ies) shall be determined by matching these results with the appropriate factory test results.

Any defective item shall be fully investigated; where the cause of the irregularity cannot be determined, it shall be assumed that the factory tests were in error; new factory tests result sheets or result sheets for inclusion in the factory suite testing handbook as appropriate shall be prepared with an explanatory note.

9.4.3.2 Testing of Spare Equipment

All equipment units provided as spares shall be tested for correct operation by substitution with working units.

9.4.3.3 Confidence Trial

On completion of the suite tests, the equipment shall be subject to a continuous confidence trial having duration of 48 hours. If this confidence trial is not within the 10^{-13} bit error rate requirement and/or alarm free, the test is continued and the alarms/errors are investigated until the problems are resolved. On completion of this confidence trial, all the stability test results shall be submitted to Purchaser for evaluation. All irregularities and variations from the specification shall be accounted for to the reasonable satisfaction of Purchaser which shall not be unreasonably withheld. In the event of an unsatisfactory explanation, Purchaser may require the tests to be repeated.

9.4.3.4 Land Cable and Return Earth System Testing

Land Cable tests will be performed after the completion of land cables installation at each site. A program for land cable testing shall be proposed by the Contractor.

The Return Earth System shall be tested after its installation at each site according to a testing program that shall be proposed by the Contractor.

9.4.4 Period III.B: Loading and Laying Tests

The Contractor will indicate to Purchaser in the SLLI the parameters to be measured or supervised during loading and laying operations to ensure that these operations are performed satisfactorily. At the end of the lay of the System the Contractor will perform a restricted list of tests before final splice is launched to pre-evaluate the System performances.

9.4.5 Period IV: Transmission Segments Contractor's Test Period

This test period will allow the Contractor of the Transmission Segments to undertake any tests previously agreed to confirm the correct operation of the Segments. All tests shall be identified by the Supplier during PDR and CDR reviews.

DC and low frequency AC tests, and OTDR tests with the System de-powered shall be carried out during this period immediately after the completion of the marine installation.

RSN Technical Specifications

COTDR tests with the System powered shall be carried out during this period immediately after the completion of the marine installation. These tests will be implemented with the Contractor LME.

The results shall be recorded in the Transmission Segments Acceptance Handbook. On completion of these tests, the Contractor shall forward the results of these tests to Purchaser offices for evaluation.

The Contractor shall provide an estimate of the total duration of this testing Period.

9.4.6 Period V: Purchaser Transmission Segments Test Period

The Supplier shall make the Transmission Segments available to Purchaser for a period of three (3) days between the completion of the installation of the submersible plant and the beginning of the System Confidence Trial to carry out their own tests.

The Supplier shall agree with the procedures used, shall observe the tests being performed and shall state to Purchaser their objection at any stage at which it considers that such procedures could affect the overall System performance. The Purchaser shall identify all tests to be performed as part of the Supplier's PDR and CDR.

Shall Purchaser tests either demonstrate that:

- The System performance is not in compliance with the present Technical Specification, or
- The Supplier's test results cannot be repeated with a reasonable occurrence, the disputed results shall be referred to the Supplier for comments or corrective actions, if applicable

In such case, Purchaser may elect to extend Purchaser test period by the time required to solve the dispute.

All information and reference data required to operate and maintain the System must be available at the beginning of this Purchaser test period.

The Supplier shall assist and support Purchaser during this test period and may be requested to carry out these tests on behalf of Purchaser.

9.4.7 Period VI - Out of Service Confidence Trial

On completion of the previous test periods of each Transmission Segment, a continuous System out of Service Confidence Trial shall follow. Purchaser and the Supplier will jointly participate in the supervision of the tests to ensure that it is carried out in a manner satisfactory to Purchaser. The tests to be performed shall be agreed to as part of Supplier PDR and CDR. The System shall be observed by monitoring the critical parameters using suitable test equipment, appropriate monitors and the recording instruments for a continuous period of seven (7) days. Carefully controlled procedures shall be established to prevent introduction of errors through human action. Any irregularity, variation alarm

RSN Technical Specifications

or non-routine event observed shall be investigated by the Supplier. A daily log recording any irregularity, variation, alarm or non-routine event and, where applicable, the suitable remedial action carried out, shall be jointly maintained by the Supplier and Purchaser Representatives. In the event of an unsatisfactory explanation of the cause of any deviation or serious discrepancy the trial shall be repeated for a new period as necessary to verify compliance with the specification. During these tests the MTE shall be used in all its functionality in order to provide reference data and confirm its proper operation.

During this period various configurations of the equipment and traffic/powering configurations mutually agreed between Purchaser and the Supplier shall be implemented. The configuration shall be based on the installed submarine plant and no additional connections shall be required on any installed Nodes ports.

The System out of Service confidence trial report shall include the following:

- a) A daily log of the Confidence Trial period; it shall include all the routine and non-routine events, alarms and problems, and remedial actions if any
- b) A complete report of the Transmission quality parameters
- c) The demonstrated level of confidence, for each transmission quality parameter, that the System complies with the requirements of the present Technical Specification
- d) A daily log of Q factor and errors corrected by the Line FEC

Transmission Segment Performance data recorded by the test equipment and transmission supervision data provided by the MTE will be compared for reference.

9.4.8 Period VII: System Integration Test Period

This test period will allow the Contractor to undertake any tests previously agreed to integrate the whole Contractor Supplied system and demonstrate the correct operation during the whole lifetime of the System. Testing shall not include any of the Purchaser's secondary infrastructure.

As a prerequisite to the beginning of this testing period, all Transmission Segments shall have passed successfully the Acceptance Testing Periods III and IV, and the Terminal Equipment shall have passed successfully the Period III.A (Site Testing).

This testing Period VII shall include but not be limited to:

- The verification of the transmission performance over the whole System
- The verification of the powering sub-system and its ability to support various powering configurations
- The verification of the Management sub-system functionality, including remote access and DCN performance
- The verification of the synchronization over the whole System, if applicable
- The verification of the protection mechanism(s), if any
- The exercising of the maintenance and restoration procedures such as fault

RSN Technical Specifications

localization

In case of unexpected results or anomalies/discrepancies, the Contractor shall be responsible for determining the cause of all discrepancies encountered during the Integration Testing and will provide Purchaser with all the technical information necessary to assess his conclusions.

In the event that the resolution of these discrepancies would require hardware or software modifications of some parts of the System, these modifications of the System (including spares) shall be taken in charge by the Contractor at no cost for Purchaser. These modifications will be subjected to Purchaser approval prior to their implementation. They shall be implemented in all the equipment concerned in the System and not on a per station/Segment basis.

The results shall be recorded in the System Acceptance Handbook. On completion of these tests, the Contractor shall forward the results of these tests to Purchaser offices for evaluation.

9.4.9 Period VIII: Purchaser System Test Period

The Supplier shall make the System available to Purchaser for one (1) period of duration of up to thirty (30) days between the completion of the System Integration (end of Period VII) and the PA date to carry out their own tests. The Purchaser shall identify all tests to be performed as part of the Supplier's PDR and CDR.

The Supplier shall agree with the procedures used, shall observe the tests being performed and shall state to Purchaser their objections at any stage at which it considers that such procedures could affect the overall System performance.

Shall Purchaser tests either demonstrate that:

- The System performance is not in compliance with the present Technical Specification, or
- The Supplier's test results cannot be repeated with a reasonable occurrence, the disputed results shall be referred to the Supplier for comments or corrective actions, if applicable

In such case, Purchaser may elect to extend Purchaser test period by the time required to solve the dispute.

All information and reference data required to operate and maintain the System must be available at the beginning of this Purchaser test period.

The Supplier shall assist and support Purchaser during this test period and may be requested to carry out these tests on behalf of Purchaser.

RSN Technical Specifications

9.4.10 Additional Tests

Any test additional to those previously agreed, which may be required by either the Contractor or Purchaser, shall be performed before commencement of the System Out of Service Confidence Trial and shall become part of the Provisional Acceptance tests and must be mutually agreed upon by both parties...

9.4.11 Reference Data

A subset of the test results collected during all the test periods constitute the Reference Data for the system

The reference data provides information on the performance of the system that is used later during the system Life to maintain it.

The list of reference data shall include, but not be necessarily limited to:

- Number of channels
- Each channel Q (min, max, mean) and BER performance
- Each channel OSNR
- Optical spectrum at each fiber termination
- All critical optical power levels
- Each segment nominal voltage
- A reference set of Submarine Plant monitored parameters
- COTDR traces

9.4.12 Period IX - System Out of Service Confidence Trial

On completion of the previous test periods, a continuous Out of Service Confidence Trial shall follow on the entire System (including all Transmission Segments). Purchaser and the Contractor will jointly participate in the supervision of the test to ensure that it is carried out in a manner satisfactory to Purchaser. The System shall be observed by monitoring critical system parameters using suitable test equipment, appropriate monitors and the recording instruments for a continuous period of 72 hours. If this confidence trial is not error free and/or alarm free, the test is continued and the alarms/errors are investigated until the problems are resolved... Carefully controlled procedures shall be established to prevent introduction of errors through human action. Any irregularity, variation alarm or non-routine event observed shall be investigated by the Contractor. A daily log recording any irregularity, variation, alarm or non-routine event and, where applicable, the suitable remedial action carried out, shall be jointly maintained by the Contractor and Purchaser Representatives. In the event of an unsatisfactory explanation of the cause of any variation or serious discrepancy the trial shall be repeated for a new period of continuous 72 hours. If this confidence trial is not error free and/or alarm free, the test is continued and the alarms/errors are investigated until the problems are resolved. During these tests the MTE shall be fully utilized in order to provide reference data and confirm its proper operation.

The Out of Service System confidence trial report shall include the following:

RSN Technical Specifications

- a) A daily log of the Confidence Trial period; it shall include all the routine and non-routine events, alarms and problems, and remedial actions if any
- b) A complete report of the Transmission quality parameters
- c) The demonstrated level of confidence, for each transmission quality parameter, that the System complies with the requirements of the present Technical Specification
- d) A daily log of Q factor

System performance data recorded by the test equipment and transmission supervision data provided by the MTE will be compared for reference.

9.5 Acceptance Tests Reporting

9.5.1 Provisional Report:

The provisional report should be issued seven (7) days following the beginning of the Out of Service Confidence Trial. It shall include an analysis of the results of all the tests included in the Acceptance Handbook for periods I to VIII of the Acceptance Tests and confirmation of all functionalities and capabilities of the System, as deemed required by Purchaser for the Provisional Acceptance including preliminary analysis of these results and any other resulting from additional tests required by Purchaser as well as an analysis of the station log.

Following the end of the Out of Service Confidence Trials, the Provisional Report shall be updated to include all the relevant events that occurred during this test period. Any other analysis or study shall be included in this report in order to allow Purchaser to decide in conjunction with the other test period's results on the acceptance of the System.

Purchaser will be allowed seven (7) days in order to analyze the results of the Out of Service Confidence Trial included in this updated Provisional Report.

9.5.2 Final Report

This document, to be issued within ninety (90) days following the end of Purchaser Test Period shall include the results of all the tests carried out during the Contractor and Purchaser Test Period, including:

- a) The System performance data and
- b) The baseline and reference data as necessary for routine operation, maintenance and repair of the System and
- c) An analysis of the results obtained and
- d) Recommendations for further routine maintenance of the System

9.6 Final Acceptance

9.6.1 Purchaser Test Period for Final Acceptance

Purchaser Test Period or so-called "System Final Acceptance" will take place prior to commencement of the Warranty Period for a period and at a precise date to be mutually agreed.

The MTE data gathered prior to the Purchaser Tests for the long-term evaluation of the transmission quality performance shall be considered as part of the Final Acceptance data.

If a pattern of failure has developed at the time of the Final Acceptance, which contradicts the reliability models provided by the Contractor as requested in this specification, Purchaser may require a redundancy reconstitution and/or an extended warranty covering all equipment similar to those affected by the pattern of failure.

The Contractor shall issue within fifteen (15) days following the end of Purchaser Test Period for the Final Acceptance the results of all the tests carried out during Purchaser Test Period, including:

- a) The System performance data and
- b) The update of baseline and reference data as necessary for routine operation, maintenance and repair of the System and
- c) An analysis of the results obtained during the warranty period and Purchaser Test Period and
- d) Recommendations for further routine maintenance of the System

Purchaser reserves the right to dispense with the Final Acceptance Tests.

9.6.2 Issuance of Certificate of Final Acceptance

The Certificate of Final Acceptance will be issued by the Purchaser upon Final Acceptance provided that:

- a) The results of the Final Acceptance Tests indicate the compliance of the System with the requirements of the Technical Specification or the System fully meets such performance requirements as may be agreed between Purchaser and the Contractor and
- b) No pattern of failure or pattern of degradation has developed that is likely to cause the System to fail to meet the requirements of the Technical Specification or such other performance requirements which may have been agreed between Purchaser and the Contractor for the twenty five year design life of the System

10 Fault Localization, Repair Method and Spares

10.1 Fault Localization

Within limitations of the selected submarine cable supplier's submarine optical amplifiers (repeaters), the Contractor shall provide the means by which faults and breaks will be localized in the submarine System including the land cable sections. These shall include if applicable:

- Failure of a Repeater, including switchable redundant components (if any), isolated to within one Repeater Section and to within a single housing
- Failure of a Primary Node
- Break in an individual fiber (cable otherwise intact)
- Complete cable break (power conductor being sealed, exposed, or exposed through high resistance to sea water)
- Low impedance Shunt (insulation) fault and to the greatest extent reasonably practical, high impedance Shunt (insulation) fault

For Land Section fault localization, the System design shall allow the localization of a complete fiber/cable break from the Terminal Station. The required accuracy is ≤ 5 meters. For complete cable breaks, fiber breaks and shunts faults in the first Repeater Section; the procedures shall enable faults to be located with accuracy 0.5 km when located from a Terminal Station.

An accuracy < 0.5 km shall be achieved over the entire continental shelf and slope areas for complete cable breaks and shunt faults when located from a Terminal Station. The accuracy of localization required in Deep Water will depend on the proposed repair technique but an accuracy of ± 5.0 km shall be considered initially when the localization is performed from a Terminal Station. The accuracy of localization when located from within section shall be < 0.1 km.

The System must be able to locate all single faults that cause the System to fail to meet the performance requirements. In the case of multiple faults, the level of ambiguity shall be minimal and it shall be possible to locate at least one fault.

The Contractor shall supply all system parameters (current/voltage, capacitance, etc., of cable, repeaters), with the necessary accuracy, which may be required for fault localization purposes.

Under the fault conditions given in this Chapter, it shall preferably be possible to continue supervision and control of any submersible equipment. The fault localization shall enable determination of the fault position to within one repeater-repeater, repeater-Primary Node or one Primary Node-Primary Node span.

RSN Technical Specifications

Fault localization (including electroding), supervision and control techniques and arrangements shall be designed to have minimal impact on traffic. In case of failure on one fiber pair only, the performance of the other fiber pairs shall not be impaired by the localization process. The Contractor shall provide information on the level of impact.

In addition to the previous requirements, Purchaser has a strong preference for a fault location method giving a much higher longitudinal resolution (accuracy on the cable within 100m). The Contractor shall indicate if his system design can provide such capability and provide a description of the principle and the implementation for this fault location method (Station/ship equipment, worst case resolution, etc.).

10.2 Electroding

The System shall permit the use of a low frequency electroding tone for submarine cable tracking and fault localization.

The Contractor shall provide a description, at PDR, of the electroding system including:

- The actual method for injecting the tone into the System, (nothing in the injection port shall preclude the use of a 4 to 50 Hz signal)
- The frequency/distance characteristic, i.e., the distance from the terminal as a function of frequency to achieve a given field strength at a fixed injected current level
- The attenuation of each item of the submersible plant for the range of frequencies between 4 and 50 Hz
- The maximum permissible applied current level both in service (i.e. without exceeding the error performance requirements) and out of service

10.3 DC Testing

For DC fault localization, the Contractor shall describe the response capability of the cable, including the effect of Repeaters, Equalizers and BUs, to conventional DC testing including Insulation Resistance testing.

The DC characteristics versus temperature of each submarine component shall be provided.

10.4 Repair Techniques

The Contractor shall describe the recommended techniques for all types of repairs, e.g. in Shallow Water with both buried and unburied cable, in Deep Water, and when Primary Nodes, Repeaters, Equalizers and BUs are involved. This description shall highlight any need for new designs of shipboard cable-handling equipment and new procedures for cable handling.

RSN Technical Specifications

The Contractor shall describe the procedures to compensate for the transmission impairment (loss, dispersion, etc.) caused by added cable (and fiber splices) required to carry out a repair at sea.

10.5 Maintenance and Fault Location Test Equipment

10.5.1 Maintenance, Test Location and Testing Equipment for Cable Ship and Depots

The Contractor shall present the maintenance equipment necessary in a cable depot or on board a cable ship engaged in a repair of the System.

Purchaser reserves the right to directly purchase part or the whole of this item from other sources.

10.5.2 Maintenance, Test Location and Testing Equipment for Terminal Station

In addition to any test equipment supplied as an integral part of the System, the Contractor shall present a complete set of maintenance test equipment for maintaining the TSE and the land cable portion and for fault localization from the station. Unit prices for such equipment shall be provided.

The Contractor shall provide recommendation on storage conditions for the TSE spares.

Purchaser reserves the right to directly purchase part or the whole of this item from other sources.

10.5.3 Documentation

The Contractor shall ensure that each set of maintenance equipment is supplied with complete specification, operating and maintenance documentation, including schematic drawings.

10.5.4 Test Equipment Maintenance Contracts

To the greatest extent reasonably practical COTS equipment, not manufactured by the Contractor and to be provided under this Contract, shall be subject to standard maintenance contracts by the equipment manufacturer throughout the Warranty Period.

These maintenance contracts shall be offered for transfer to Purchaser at the Final Acceptance Date.

The Contract will include the calibration data of test equipment, supplied under the Contract.

The Contractor will specify the frequency, schedule and specification of calibration for all test equipment provided under the Contract.

RSN Technical Specifications

10.6 Cable Jointing, Fiber Splicing and Procedures

10.6.1 General

For maintenance purposes, Purchaser has not decided whether to use the Universal Joint or Millennia technology. For quotation purposes, the Contractor shall offer an itemized list of jointing kits of either the Universal Joint or Millennia technology.

Purchaser reserves the right to directly purchase part or the whole of this item from other sources.

10.6.2 Delivery

Spare jointing kits shall be made available at the latest two (2) weeks before the starting of the loading operations. All jointing kits will be loaded on board the laying cable ship(s) and off-loaded in the designated cable depots at the end of the laying operation.

The recommendations for the environmental conditions (e.g. temperature and humidity limits, protection against light, etc.) to be applied during the long-term storage of the jointing kits shall be given by the Contractor.

10.6.3 Quantity

The Contractor shall offer the appropriate number and type of spare jointing kits that are consistent with the spare submersible plant offered in their response.

10.7 Spare Plant

10.7.1 General

The System shall include spare plant, made up of Terminal Equipment spares, spare Repeaters, spare Equalizers (if applicable), spare BU's, spare Primary Node and spare submarine, land cables and return earth cables where applicable.

10.7.2 Delivery

Spare submersible plant shall be made available at the latest two (2) weeks before the starting of the loading operations. All submersible spares will be loaded on board the laying cable ship(s) and off-loaded in the designated cable depots at the end of the laying operation.

The spare land cables and the Terminal Equipment spares shall be delivered to each terminal station at the beginning of the installation work at each site.

10.7.3 Storage Conditions of the Submersible Plant

For quotation purpose, a complete set of spares of the submersible plant will be stored in cable depot(s) selected by Purchaser. Purchaser will specify the location of the depot(s).

RSN Technical Specifications

The recommendations for the environmental conditions (e.g. temperature and humidity limits, protection against light, etc.) to be applied during the long-term storage of the spares of the submersible plant shall be given by the Contractor.

The Contractor shall provide Purchaser with factory test data for all these spare submersible plant items mentioned above, at the time of delivery, so that performance can be re-tested by Purchaser from time to time.

The Contractor shall specify and give details of the tests to be undertaken for each item of the spares of the submersible plant, before deployment in a repair, as well as the test equipment required.

10.8 Spare Quantities

10.8.1 Sparing Methodology

The Contractor shall describe the method used to establish the number of spares in accordance with (a) the overall reliability and transmission availability requirements, (b) the FIT rate and population of individual modules, units and circuit packs that are field replaceable and (c) the Mean Time To repair (MTTR) of those field replaceable modules, units and circuit packs.

10.8.2 Terminal Station Equipment Spares

10.8.2.1 Definition

At each terminal station, the TSE spares shall be made up of the same elements of equipment (electronic cards, etc.) that are specifically used in the station.

10.8.2.2 Quantity

The Contractor shall provide an itemized list of recommended spares to cover the maintenance of the Terminal Station Equipment over the whole System's Design Life so that the overall reliability and outage requirements are met throughout the whole System Design Life bearing in mind the Repair Method and Repair Agreement (see Sub-Paragraph hereafter).

More specifically, prices for the following spares shall be provided:

- For the PFE, one or several spare(s) for each type of electronic card, component or sub-assembly used in the equipment. The quantity should be sufficient to support the overall reliability requirements
- For the SLTE, one or several spare card(s) for each type of card. The quantity of spare cards shall be enough to reconstitute a fully equipped non-duplicated SLTE. The quantity should be sufficient to support the overall reliability requirements

RSN Technical Specifications

10.8.2.3 Repair Method

The Contractor shall present a repair method for all the Terminal Station Equipment elements so that the overall performance requirements are met throughout the System Design Life.

The Contractor shall state the estimated turn-around time for repairs.

10.8.3 Spare Repeaters, Equalizers and Branching Units (If applicable)

10.8.3.1 Definition

The characteristics of each spare Repeater, Equalizer and BU shall be such as to allow its use in place of any line Repeater, Equalizer or BU without impairing the overall System performance.

Each spare Repeater or Equalizer shall be fitted with its two complete couplers, each of them being jointed to 30 (thirty) meters of SA cable in order that its connection to the System shall only require to perform two Universal Joints.

Each spare BU shall be fitted with its three complete couplers, the one in the main trunk being jointed to 250 meters of LWA cable and the two in the spurs being jointed to 80 (eighty) meters of SA cable in order that its connection to the System shall only require to perform three Universal Joints.

The end of each cable tail shall be covered by safety caps ensuring the required cable sealing and providing electrical and optical connectors for testing purpose.

10.8.3.2 Quantity

The Contractor shall provide a quote for 5 % of the number of submerged Repeaters, Equalizers and BU's (1 PBU and 1 BU/PSN) (if applicable) that Purchaser intends to store in their cable depots to cover the maintenance of the System.

The Contractor shall provide a recommendation of the number of spare BUs, spare Equalizers and spare Repeaters.

10.8.3.3 Repair Method

The Contractor shall present in his System Description a repair method for all the Primary Nodes and Repeaters, of the System so that the overall System performance is met throughout the System Design Life. The Contractor shall indicate the estimated turnaround time for such repairs and demonstrate his compliance with the overall availability criteria.

RSN Technical Specifications

10.8.4 Spare Cable

10.8.4.1 Definition

The characteristics of each piece of spare cable shall be the same as those of the relevant line cables.

For each cable type (LWP, SA, RA, etc...), the quantities of each fiber type shall be determined in such a way repairs to any System segment will be possible without impacting the System transmission performance, in particular in relation with the maintenance of the Chromatic Dispersion map.

The ends of each piece of spare cable shall be covered by safety caps ensuring the required cable sealing.

The spare land cables shall be supplied on metallic cable drums of suitable construction such that they remain serviceable throughout System Design Life and that the cable maintains its nominal characteristics.

10.8.4.2 Quantity

The Contractor shall quote for the following list of spare cable quantities:

LWP:	3% of the LW and LWP in the submerged plant
LWA:	based on an allowance for a single repair based on the maximum deployment depth of LWA cable plant
SA/RA:	None
Land Cable:	0.6km per cable type
Beach joint:	1 spare Land cable joint: 2 spares per cable type

10.8.5 Spare Primary Nodes

10.8.5.1 Definition

The characteristics of each spare Primary Node shall be such as to allow its use in place of any other Primary Node without impairing the overall System performance after the appropriate set of optics are installed in the spare unit.

Each spare Primary Node shall be fitted with all its two external coupling components, and protective devices.

10.8.5.2 Quantity

The Contractor shall provide a recommendation of the number of spare Primary Nodes.

10.8.5.3 Repair Method

The Contractor shall present in his System Description a repair method for all the Primary nodes of the System so that the overall System performance is met throughout

RSN Technical Specifications

the System Design Life. The Contractor shall indicate the estimated turnaround time for such repairs and demonstrate his compliance with the overall availability criteria.

10.9 Spares Test Program

The Contractor shall detail the tests that it would recommend being undertaken on each item of the spare line plant, including Repeaters, Equalizers, BU's and Primary Nodes in depot, before deployment in a repair, as well as the test equipment required.

11 Documentation

11.1 Scope

This Chapter details the requirements for the content and the approval procedures for all the technical documents, drawings and handbooks to be provided by the Contractor for the engineering, manufacture, quality assurance, quality control, installation, in-station acceptance tests and maintenance of all the equipment items as well as the whole System.

The Contractor shall provide documentation in electronic format, including CD-ROMs or data DVD upon request. The format shall be pdf, or to be mutually agreed. The Files shall be structured, printable and searchable. Documentation for SLDs and RPLs shall be provided in both pdf and spreadsheet formats. Documentation for charts shall be provided in both pdf and cad drawing formats.

11.2 Language

The provisional and final documentation shall be in English.

11.3 Submission and Acceptance of Documentation

11.3.1 General

Any issues of documents shall be previously supplied to Purchaser for comment and approval. Each page of each document shall have clearly marked, as a minimum:

- The page number
- The issue number
- The issue Date

If it is a DRAFT, "DRAFT" should be clearly marked on each page

Purchaser will acknowledge receipt of the documents and will respond within fourteen (14) days of the date of receipt.

If no response is provided, the documents will be considered as approved.

11.3.2 Approval

If documentation submitted for approval is not approved, Purchaser will make comments. The Contractor must accept these comments and amend its documentation for re-submission. When the documentation is approved it shall become a contractual commitment on the part of the Contractor. All re-issued documents shall be forwarded to Purchaser for their information and approval as appropriate.

RSN Technical Specifications

All re-issued documents must be identified with a new issue number and a new issue date.

The approval of the content and structure of the documentation shall be definitive at the final PA date of the system. The amendments required during the Warranty Period shall be limited to the correction of errors.

11.4 Supply of Documents

The documentation submitted for approval and comment shall be supplied in accordance with the time schedule and quantities that will be negotiated at a later date.

The initial and pre-manufacture information may be subject to amendments and additions as Contract implementation proceeds, but it shall be supplied to Purchaser to supplement information submitted as part of the Contract, and shall demonstrate compliance with the requirements of the Contract.

Wherever applicable this information shall be periodically re-issued as necessary and submitted to Purchaser.

One copy of the final documentation drawings to be provided to Purchaser shall be submitted in a reproducible form. In addition, the marine operation documentation will be provided. The content of the documentation shall be provided in format and media which is compatible with standard office computing and software packages; e.g. Acrobat Reader.

11.5 Standard Requirements

The whole documentation set shall conform to a standard acceptable to Purchaser. To the greatest extent reasonably practical, these shall contain standardized symbols and vocabulary as those recommended by the ITU and the IEC.

Each set of technical documentation shall be provided with a detailed table of contents.

11.6 Drawing Standards

11.6.1 General

Drawings shall be provided in an electronic format and the drawing files must be generated with mutually agreeable commercially available software such as Acrobat pdf, Microsoft Office, Solidworks or AutoCad.

11.6.2 Drawings Amendments

Any amendments to any Purchaser deliverable document to the System shall cause that drawing to be re-issued in accordance with the standard practices agreed with Purchaser.

RSN Technical Specifications

All amended Purchaser deliverable document shall be submitted to Purchaser for comment.

11.7 Handbook Presentation

11.7.1 Identification

Each handbook shall be simply identified, e.g. by a number and prefix letter. The method used for issue identification shall be subject to the approval of Purchaser.

11.7.2 History Sheet

A page shall be provided to record the main changes incorporated in each approved issue, with dates. Purchaser approval references shall also be given.

11.7.3 Drawings

Handbooks shall be provided with all the drawings necessary for a full understanding of the equipment and shall typically include schematics and block diagrams at the end of the part to which they relate, with the addition of simple explanatory drawings and diagrams as necessary. Such additional drawings shall be prepared so that their relationship with the main drawing is apparent.

11.8 Initial Post Contract Documentation

Within two (2) months of the Coming into Force of the Contract the Contractor shall submit the following documentation:

11.8.1 Straight Line Diagram

The Straight Line Diagram (SLD) shall be updated by the Contractor as necessary until the final PA date of the system.

11.8.2 Route Position List

Route Position List (RPL) shall be updated by the Contractor as necessary until the final PA date of the system. As a minimum this list shall include the following:

- Route positions expressed as both Longitude/Latitude and Universal Transverse Mercator (UTM)
- Cable length between route positions
- Cable slack
- Cumulative cable lengths
- Cable types
- Burial depth

11.8.3 Plan of Work

An updated issue of the Plan of Work (GANNT) shall be provided in accordance with the requirements specified by Purchaser.

RSN Technical Specifications

11.8.4 Survey and Marine Operations Schedule

A detailed program of the survey and marine operations shall be updated as necessary.

11.8.5 Contractor's QA Handbook

The Contractor's QA Plan and Test Plan covering all items of the Contract shall be submitted for comments and approval.

11.8.6 Components and Materials

The Contractor shall provide a list of unqualified and critical components he intends to use on the System, indicating on which submarine cable project, if any, these components and materials have been used.

11.8.7 Training Courses Information

Detailed syllabuses, time schedules and contents of the training courses shall be provided.

11.8.8 Documentation Master List

An updated documentation master list, including a breakdown of each handbook into separate parts, with target dates for their submission to Purchaser for information, comment or approval, fulfilling the needs specified in this Chapter and in this Specification, shall be provided.

11.9 Pre-Manufacture Documentation

Within three (3) months before the starting of the manufacture of the relevant equipment the Contractor shall submit the documentation listed hereafter.

11.9.1 Descriptive Handbooks Contents

Descriptive handbooks shall contain a clear technical description of the various equipment and their constituent parts to enable both field and headquarters maintenance and acceptance staff to gain the necessary understanding of their function, operation and maintenance.

11.9.1.1 System Description Handbook

This shall include the following:

- a) A complete list of all handbooks
- b) A brief description of all parts of the System
- c) Details of System target performance
- d) A brief description of the main transmission path for each terminal, including block schematics
- e) A detailed description of the submersible plant
- f) A description of the rack layouts at each terminal station
- g) A description of the equipment construction practice, equipment numbering and document numbering system

RSN Technical Specifications

11.9.1.2 Terminal Station Equipment Handbooks

These shall include separate handbooks for SLTE, PFE, MTE, optional test equipment and other associated apparatus, and shall include:

- a) Block diagrams
- b) Description of each equipment: card level, shelf level
- c) Description of hardware and software
- d) Concise operating and routine test instructions
- e) Fault-finding information using basic test equipment
- f) Management information

11.9.2 SLTE and Interconnecting Equipment Block Diagrams

As a minimum, transmission equipment block diagrams shall include the following details:

- Main transmission paths including redundancy arrangements
- Maintenance arrangements

The block diagrams shall include the following details:

- i. The title of each unit, as it is intended to be marked on the equipment
- ii. The drawing number of each unit
- iii. The location of each unit on the shelf/rack/equipment
- iv. Test points
- v. Transmission references at test points, as expected in designed System operation
- vi. All references at interface points
- vii. The adjustable range of all adjustable quantities as well as their designed nominal level

11.9.3 SLTE/Interconnecting Equipment Face Layout Drawings

As a minimum, transmission equipment face layout drawings shall clearly show:

- i. All individual rack, shelf and major unit titles and drawing codes
- ii. Positions of all shelves which contain switches, monitors, and all other access points required for maintenance
- iii. Cabling of main transmission path on a marked-up print of the face layouts
- iv. Height of shelves above the floor

11.9.4 PFE Block Diagrams

As a minimum, PFE block diagrams (covering Power Cubicle) shall include the following details:

RSN Technical Specifications

- i. The main power path, showing power converter arrangement, the input and output terminal connections and supply voltage requirements, transformer tappings and voltage-chain tappings
- ii. Auxiliary and alarm units in block form with drawing code and title for each unit. All terminal reference numbers on each unit shall be marked and main inputs and outputs designated
- iii. Test points, recorder connections, meters and other maintenance facilities
- iv. Connection points to other equipment (MTE)
- v. Safety switches associated with the safety interlock arrangement
- vi. The cable termination splitting the optical fibers and the power conductor

11.9.5 PFE Face Layout Drawings

As a minimum, PFE face layout drawings shall clearly show:

- i. Rack title and drawing code
- ii. Front panel, unit titles, drawing codes and functions
- iii. Position of all units which contain switches, monitors, measurement point's alarms, etc. required for maintenance
- iv. Height of panels above the floor

11.9.6 Management Terminal Equipment (MTE)

As a minimum, the MTE description shall include the following:

- i. A list of the hardware items to be included in the MTE, with precise supply references (manufacturer, internal references, etc.)
- ii. Manufacturer's documentation
- iii. Complete block diagram description of the MTE system, including software and hardware documentation and interconnectivity cabling
- iv. The MTE Operating and Maintenance procedures

11.9.7 Network Management System Description (NMS)

As a minimum, the NMS description shall include the following

- i. A list of the hardware items to be included in the NMS, with precise supply references (manufacturer, internal references, etc.)
- ii. Manufacturer's documentation
- iii. Complete block diagram description of the NMS system, including software and hardware documentation and interconnectivity cabling
- iv. The NMS operating and maintenance procedures
- v. DCN description

11.9.8 Submersible Plant Handbook

This shall include the following:

RSN Technical Specifications

11.9.8.1 Cable

As a minimum, this shall include (except where considered company proprietary):

- a) Detailed information on cable types used in the System, including a list of construction specifications, details of the electrical, optical and mechanical parameters and the weight per kilometer of cable in air and water and the cable hydrodynamic constant of each type of cable
- b) Testing specifications and procedures
- c) Jointing specifications and procedures
- d) Detailed information on cable joints and cable housing joints

11.9.8.2 Repeaters

As a minimum, this shall include (except where considered company proprietary):

- a) Detailed description of the repeaters used in the System, including a list of construction specifications and details of the electrical, optical and mechanical parameters
- b) A detailed description of the repeater supervisory system
- c) Specifications related to general production standards
- d) Specifications related to the production, control and environment
- e) Factory test specifications that shall at least include engineering production limits, testing procedures and equipment

11.9.8.3 Primary Nodes

As a minimum, this shall include:

- a) Detailed description of the Primary Nodes used in the System, including a list of construction specifications and details of the electrical, optical and mechanical parameters
- b) Specifications related to general production standards
- c) Specifications related to the production, control and environment
- d) Factory test specifications that shall at least include engineering production limits, testing procedures and equipment

11.9.8.4 System Assembly Handbook

This shall contain the following:

- a) A detailed report on System assembly operations
- b) A detailed block schematic, showing how the System assembly tests were carried out
- c) A detailed description of all tests to be performed
- d) A detailed description of all tests to be performed under fault conditions if applicable

RSN Technical Specifications

11.10 Pre-Factory Testing Documentation

At least two (2) months before the starting of the relevant test activity specific to technical specifications, at the factory or on site, a provisional issue of the relevant test procedures and specifications covering complete equipment, shall be submitted to Purchaser for comment and approval.

11.10.1 Factory Terminal Station Equipment Suite Test Handbook

This shall contain a copy of all Factory Suite Test Specifications and copies of completed test result sheets and explanatory introduction.

11.10.2 In-station Installation and Suite Test Handbook

This shall include the installation specifications and the installation testing, including copies of completed suite test result sheets. It may form a combined handbook with Factory TSE Suite Test Handbook.

11.11 Pre-Installation Documentation

11.11.1 Terminal Station Equipment Installation Instructions

Two (2) months before TSE installation commences, the Contractor's installation instructions, covering TSE installation, power distribution and cabling shall be made available to Purchaser for comment and approval.

These provisional installation drawings shall include:

- a) The building and structural plans, where applicable
- b) TSE rack layout
- c) Power distribution and rack fusing instructions
- d) Power distribution methods and instructions
- e) Cabling methods and instructions
- f) Cable racking and superstructure (where applicable)
- g) TSE suite lighting (where applicable)

One (1) month before the start of the TSE installation, the here above approved issue of the installation drawings shall be made available to Purchaser Representatives on site.

During installation and further Acceptance Test Period, these documents may be subject to change arising from errors, agreed changes to equipment or installation, deviations from quality (drawing standards), etc. and the Contractor shall subsequently re-issue them as required.

Within Two (2) months before the scheduled PA date of the System, copies of the corrected drawings (including final versions of block schematics) shall be submitted to Purchaser for comments and approval.

RSN Technical Specifications

11.11.2 Land Cable and Return Earth System Installation Instructions

Two (2) months before the start of land cable or return earth system installation, the Contractor's installation instructions/procedures, covering land cable and return earth system installation and jointing, shall be made available to Purchaser Representatives on site for comments and approval.

The land cable provisional installation documentation shall include:

- a) A survey report on the land cable route
- b) The land cable installation drawings
- c) The return earth system installation drawings

One (1) month before the start of land cable installation, the here above approved issue of the installation drawings shall be made available to Purchaser Representatives on site. During installation and further Acceptance Test Period, these documents may be subject to change arising from errors, agreed changes to installation deviations from quality (drawing standards), etc. and the Contractor shall subsequently re-issue them as required.

11.11.3 System Loading and Laying Instructions

Two (2) months before the first loading, the Contractor's SLLI shall be made available to Purchaser for comment and approval. These instructions shall at least include:

- a) Procedures for all marine activities including assembly, loading and laying/burial
- b) Tests to be carried out on the submersible plant both during assembly, loading and subsequent laying to ascertain the System margins
- c) Specimen test forms
- d) Specimen inspection check sheets
- e) Proposals for measuring any parameters that may be required to explain any changes of performance in transfer from the ship to the seabed
- f) Work to be undertaken by cable ship
- g) Power safety procedures

11.11.4 Burial Assessment Survey (BAS) Report

Within one (1) month of completion of the Burial Assessment Survey (BAS) the Supplier shall make available to Purchaser for comment and approval a preliminary BAS Report that shall include:

A. Charts

All required BAS data shall be depicted on survey charts so that a direct comparison with other information already on the charts can be made.

As a minimum the following information shall be depicted on survey charts where seabed samples and Cone Penetrometer tests were undertaken:

- Any pertinent and important margin notes
- Results of the CPT including sediment density or shear strength

RSN Technical Specifications

Correlation between charted results and narrative shall be provided.

B. Text

A detailed narrative report to supplement and explain thoroughly the data presented on the charts that will include a comprehensive list of co-ordinates through the Burial Assessment Survey was conducted. As a minimum, this narrative report shall include the following:

- a) Predicted plow tow tensions
- b) Predicted share/tools penetration depth
- c) Recommendation for plow depth settings along the route
- d) Recommendation for plow share point change positions
- e) Recommendation for cable armoring
- f) Sediment density or shear strength
- g) Summary table of route length versus burial category
- h) Updated Route Position List for recommended cable route
- i) Environmental conditions observed, including wind and sea conditions, surface currents
- j) Recommendation for cable route engineering and installation
- k) Shipping traffic, offshore engineering activities and fishing activities observed together with any exchange of radio regarding these
- l) A log diary as an appendix to the report. Such log/diary shall indicate all significant field activities from mobilization to demobilization and shall include a list of key personnel and their responsibilities, evaluation, equipment breakdown/repairs summary, etc.

11.11.5 Route Clearance Report

Within one (1) month of the completion of the Route Clearance Operation or Marine Installation, whichever is the later the Contractor shall make available to Purchaser for comment and approval a detailed narrative report to supplement and explain thoroughly the data presented on the charts. As a minimum this report will include:

- a) A comprehensive list of co-ordinates through which the clearance operations were conducted
- b) Full details of any out-of-use cables recovered, including their description, lengths recovered and co-ordinates of the ends. This will be presented in a tabulated form for easy referencing so that cable records can be updated
- c) Method by which each cable end was anchored
- d) Environmental conditions observed, including wind and sea conditions, surface currents
- e) Shipping traffic, offshore engineering activities and fishing activities observed together with any exchange of radio regarding these

RSN Technical Specifications

- f) A log/diary as an appendix to the report. Such log/diary shall indicate all significant field activities from mobilization to demobilization and shall include a list of key personnel and their responsibilities, evaluation, equipment breakdown/repairs summary, etc.

11.11.6 Plow Burial Inspection/PLBO Report

Within one (1) month of the completion of the Plow Burial Inspection/PLBO or Marine Installation, whichever is the later, the Contractor shall make available to Purchaser for comment and approval a Plow Burial Inspection/PLBO Report that shall include:

A. Charts

All acquired Post Lay Inspection data shall be depicted on survey charts so that a direct comparison with other information already on the charts can be made.

B. Text

A detailed narrative report to supplement and explain thoroughly the data presented on the charts that will include a comprehensive list of co-ordinates through which the Post Lay Inspection was conducted.

As a minimum, this narrative report will include the plow depth along the route.

11.11.7 Daily Reports

The Contractor shall submit to Purchaser a daily report System E-mail (preferred) or Fax during all marine operations described in this Specification. The content of such reports shall include:

- a) Geographical position of the cable ship at the time of the report
- b) Summary of the work performed during the preceding 24 hours, to the nearest 15 minutes
- c) Summary of the planned work for the next 24 hours
- d) Time spent on effective work during each 24-hour period and the cumulative total
- e) Weather downtime during each 24-hour period and the cumulative total
- f) Cable ship/plant down time during each 24 hours period and the cumulative total
- g) Details of any problems encountered
- h) Endorsement of the report by Purchaser onboard representative
- i) Summary of plant installed and burial performance

The exact content and distribution of the reports will be discussed and agreed with Purchaser.

11.12 Post-Installation Documentation

11.12.1 Interim Laying Report

Within 24 hours of completion of the submersible plant installation unless otherwise agreed with Purchaser the following interim information shall be provided:

RSN Technical Specifications

- a) As-laid Route Position List (provisional issue)
- b) The exact position of all parts of the submersible plant that were not buried (as applicable)
- c) Final test results (raw data)
- d) As laid Straight Line Diagram (provisional issue)
- e) Other information, including charts, upon demand, in the eventuality of a fault occurring on the System Contractor will work closely with the Purchasers to provide the information required to work the issue including impromptu provisional charts where required to understand the situation.

11.12.2 Load and Laying Report

Within two (2) months of the completion of the submersible plant installation the Contractor shall make available to Purchaser for comment and approval a preliminary Laying Report which shall include separate Paragraphs under the here below specified headings.

As a minimum this report shall include:

A. Charts

- a) The position of the submersible plant as recorded during the installation depicted on survey charts
- b) The burial depth achieved at any point along the route depicted on survey charts
- c) Any pertinent and important margin notes

B. Text

- a) A detailed narrative installation report including all field data from which the charts mentioned in A here above were generated
- b) A diary of events from mobilization to demobilization. This shall include all significant field activities as well as a list of key personnel and their responsibilities, evaluation, equipment break down/repairs summary, etc
- c) Testing Officer's report including all tests data acquired from mobilization to demobilization
- d) Route Position List showing the exact location of the submersible plant, installed slack achieved at all points along the route, alter course positions, cable tension and other events
- e) Straight Line Diagram showing the final configuration of the submersible plant and indicating where burial was and was not achieved and depth of burial
- f) Comparison of burial depth achieved along the route with target depth
- g) Navigation report
- h) Environmental conditions observed, including wind and sea conditions, surface current, etc.
- i) Shipping traffic, offshore engineering activities and fishing activities observed together with any exchange of radio messages regarding these

RSN Technical Specifications

The precise content of each paragraph shall be discussed and agreed with Purchaser two (2) months prior to the commencement of the installation activities.

11.12.3 Assembly, Load and Laying Test Report

No later than two (2) month after completion of the submersible plant installation the Contractor shall make available to Purchaser for comment and approval a preliminary Assembly, Load and Laying Test Report which shall include separate paragraphs under the here below specified headings. The precise content of each paragraph shall be discussed and agreed with Purchaser two (2) months prior to the commencement of the installation activities.

As a minimum, this report shall include:

- a) A detailed list of all tests made and the results obtained during the assembly, loading and laying operation
- b) A set of samples of test forms used together with the details of any concession granted or unusual condition detected during the loading and laying operation
- c) A simple block schematic, showing how the tests were carried out and details of the equipment used
- d) A detailed list of all tests and results obtained under any fault conditions

11.12.4 Updating of Handbooks

No later than one (1) month before the scheduled PA date of the system, the provisional issue of the handbooks showing a detailed description of the System, submersible plant and TSE shall be made available to Purchaser Representatives for comment and approval. These handbooks shall include the updated manufacture documentation, the pre-installation documentation as well as test results.

Moreover, some plastic-coated drawings, to be displayed in each station, shall be provided for current System operation. As a minimum, it shall include:

- a) A SLD including the Identification Codes or whatsoever to be used for the remote control of each repeater.
- b) A simplified map and sea bottom profile of the System cable route showing the cable route and the repeater positions.
- c) A detailed block diagram of the TSE showing its overall functional organization, its breakdown in cards, units and shelves, all of the test and monitor points and the interface ports.

11.12.5 Acceptance Report Template

No later than four (4) months before the scheduled PA date of the system the format of the provisional issue of the Acceptance Report shall be made available to Purchaser for comment and approval. See Chapter on Acceptance Requirements for details.

RSN Technical Specifications

11.12.6 O&M Recommended Procedures

No later than three (3) months before the scheduled PA date of the system, the provisional issue of the O&M documentation covering System and TSE routine and corrective maintenance activity, spare testing and sea repair activity shall be made available to Purchaser for comment and approval.

The final O&M documentation shall be delivered no later than two (2) weeks before the final PA date of the system.

Repair and return procedures to be applied to every faulty part shall be provided.

11.13 Updating of Documents and Reports

The PA Report and updating of the whole contractual documentation shall be made available to Purchaser three (3) months after the issue of the PA Certificate.

12 Training of Personnel

12.1 Purpose of the Chapter

The purpose of this Chapter is to define the content and the conditions of the comprehensive training the Contractor shall provide to Purchaser technical staff.

12.2 Scope of the Training

The Contractor shall program and conduct all the necessary training for Purchaser personnel in an efficient manner so that such personnel shall be well trained, proficient and capable of independently carrying out testing, operation and maintenance of the System.

The Contractor shall present a quotation for the three types of training defined hereafter, on the basis of four training sessions (A, B1, B2 and C) per landing point.

12.2.1 Type A Training

This training shall be undertaken at the Contractor's factory and/or training school to Purchaser personnel with a high level technical background who shall have administrative and supervisory responsibilities with respect to the System.

The training shall be both academic and practical in nature such that the trainees are able to understand the design philosophy of the System down to component level, analyze the System performance and have sufficient knowledge to maintain its performance throughout its Design Life.

The training shall have been successfully completed prior to the commencement of the factory testing of any part of the System.

12.2.2 Type B Training

Type B training shall consist of Type B1 - Equipment training, Type B2 - System training. During these courses, the trainees shall have full access to the full station/System equipment under the control of the instructor.

12.2.2.1 Type B1 - Equipment Training

This training shall be provided for each terminal station on Purchaser premises to Purchaser operating personnel and shall include on-site practical training and instruction on the maintenance procedures of each piece of equipment including any type of test equipment supplied under the Contract.

12.2.2.2 Type B2 - System Training

This training shall follow Type B1 training and shall be performed during Purchaser evaluation period.

RSN Technical Specifications

This training shall be provided for each terminal station in Purchaser premises to Purchaser operating personnel who attended the Type B1 training.

The training shall be practical in nature, shall be conducted by instructors with deep knowledge of the System, in particular from the operation and maintenance point of view.

12.2.3 Type C Training

The Contractor shall provide, as an option, training at each station or at Purchaser premises to Purchaser staff in charge of the jointing and splicing of land cables.

12.3 Training Quotation

12.3.1 Type A Training

The quotation for type A training is based only on the cost of the provision of instructors, class/lecture rooms for the training activities, course handbooks and consumables.

The Contractor shall state the minimum and maximum number of trainees that can be accommodated simultaneously for each course.

12.3.2 Type B Training

The quotation for type B training shall be based only on the cost of the provision of instructors, including travel, residential accommodation and subsistence, course handbooks and consumables, etc. Purchaser will provide class/lecture rooms for the training activities.

The Contractor shall state the maximum number of trainees that can be accommodated simultaneously for each course.

12.3.3 Type C Training

The quotation for type C training shall be based only on the cost of the provision of instructors, including travel, residential accommodation and subsistence, course handbooks and consumable, etc.

Purchaser will provide class/lecture rooms for the training activities. During this course the trainees shall realize the necessary number of joints in order to meet the objective of the course.

The Contractor shall state the maximum number of students that can be accommodated simultaneously for each course.

RSN Technical Specifications

12.4 Course Content

12.4.1 General

The Contractor shall provide a provisional syllabus for the courses, together with the expected duration of each training session and a timetable showing the approximate time devoted to each section of the syllabus.

Within two (2) months of the Coming into Force of the Contract, the Contractor shall submit detailed syllabuses and time schedules including detailed course contents for Purchaser approval.

A proposed course objective for the A and B courses is shown as a guideline below. For each course, the Contractor shall take into account the difference in personnel levels, technical backgrounds and responsibilities within the System.

12.4.2 Course objectives

12.4.2.1 Type A Training

The following are the objectives:

- a) To enable the trainees to understand the basic optical transmission principles, including DWDM transmission, optical amplification, optical equalization and chromatic dispersion compensation
- b) To enable the trainees to understand the submarine system design and the System configuration
- c) To enable the trainees to understand basic design, planning, engineering, installation and commissioning of submarine cable systems and maintenance requirements
- d) To enable the trainees to understand the function of each part and modular unit of the system
- e) To enable the trainees to understand the technical reasons for all the parameters specified in the Specification and to evaluate the System performance against all these parameters
- f) To enable the trainees to operate, test and adjust the System and be able to supervise others to do the same
- g) To enable the trainees to rectify the System in the event of a fault in the System and be able to supervise others to do the same
- h) To enable the trainees to complete a repair of the undersea plant

On completion of the course, the trainees shall be able to:

RSN Technical Specifications

- a) Understand the philosophy behind the system designs adopted by the equipment manufacturer
- b) Understand the system designs, and functions
- c) Understand system SLD
- d) Understand the System DC powering equipment including PFE, Branching Units, the Power Switch Network and the Powering configuration options
- e) Operate and maintain the system in accordance with standards specified
- f) Evaluate system performance from measured data and reports so as to detect any early warnings of degradation
- g) Understand the philosophy behind certain test procedures
- h) Set up test equipment and perform routine/fault and localization/post-repair measurements
- i) Supervise/install the terminal equipment
- j) Understand all system parameters and compute design parameters such as performance parameter objectives, span loss budget and dynamic range budget
- k) Implement safety procedures
- l) Understand the philosophy and structure of the documentation and use it
- m) Prepare a specific routine maintenance program for the terminal station
- n) Understand the philosophy and implementation of System undersea plant repair.

12.4.2.2 Type B Training

This training shall be provided for each Terminal Station in Purchaser premises to Purchaser operating personnel.

The training shall be practical in nature, shall be conducted by instructors with deep knowledge of the System, in particular from the operation and maintenance point of view.

Type B1 Training Objectives:

- a) At the beginning of the training session, the trainees shall be provided with basic optical transmission principles and DWDM background
- b) To enable the trainees to understand the System configuration and the function of each part and modular unit of the System
- c) To enable the trainees to participate in the commissioning of the System
- d) To enable the trainees to operate, test and adjust the System and to understand the technical reasons for such adjustments
- e) To enable the trainees to operate, test and adjust the System using the recommended test equipment
- f) To enable the trainees to rectify the System in the event of a fault in the System

RSN Technical Specifications

On completion of the course, the trainees shall be able to:

- a) Understand System SLD
- b) Understand the system designs, functions
- c) Understand the test procedures, set up test equipment and perform routine/fault localization/post-repair measurements
- d) Operate and maintain the System in accordance with the standards specified and the routine maintenance program
- e) Supervise/install the terminal equipment
- f) Understand all the System parameters and compute design parameters such as performance parameter objectives, span loss budget and dynamic range budget
- g) Understand the structure of the documentation and use it

Type B2 Training Objectives:

- a) To enable the trainees to understand, manage, operate, maintain and control the whole System
- b) To enable the trainees to have a deep knowledge of the MTE and NMS, especially how this equipment interacts with other elements of the System. Special attention shall be dedicated to the dialogue between terminal stations and between terminal station and submersible plant, as well as how to locate defaults in the System

On the completion of the course, the trainees shall be able to:

- a) Implement the Power Feeding Safety Procedures adopted for the powering and de-powering of the System during maintenance work and emergency conditions
- b) Select and implement, in the shortest possible time, the Power Feeding Configuration following the occurrence of a fault or after a repair
- c) Operate the Supervisory System in order to change the BU power configuration
- d) Implement the procedures and perform the fault localization in the submerged part of the System when needed
- e) Operate, maintain and control the System in the required standard

12.4.2.3 Type C Training

The objective of this course shall be to train and qualify Purchaser Personnel to undertake the jointing of the land cable portion and beach joint. At the end of this training course, the trainees shall be able to make a repair joint in any land cable section and beach joint without degrading the performance of the System.

RSN Technical Specifications

12.5 Training Organization

12.5.1 Standardized Symbols and Vocabulary

The training materials shall be written in as simple a manner as possible using standardized symbols and vocabulary recommended by ITU/IEC. Where technical terms not incorporated in standard international glossaries are used, the Contractor shall supply a concise technical glossary.

12.5.2 Language

The training shall be conducted in English and all instructors shall be thoroughly proficient in the language, especially spoken English. The Contractor shall provide six weeks prior to the start of the training the CV of the proposed instructor. Purchaser reserves the right to comment on the CV and qualifications of the proposed instructor and provide comments within 2 weeks of submission of the CV and request a replacement if the proposed instructor is found to be deficient. The Purchaser cannot request replacement of instructor during the course.

12.5.3 Training Materials

The Training Handbook for each course shall be based on a comprehensive system of functional documentation in order to make easier a smooth transfer of responsibility of training to Purchaser for future courses.

Electronic versions of the training materials for the proposed courses shall be supplied before the course commences. Hardcopies of the training material will be provided to each trainee during the course. Three (3) sets of these training materials shall also be supplied for each terminal station before the course commences for use of Purchaser.

For all training sessions, training materials shall be available to Purchaser 2 weeks before training starts. Purchaser reserves the right to postpone the training session, if the material is not available on time.

The Contractor shall also provide each Terminal Party with one (1) set of instructor's notes and instructional materials, e.g. transparencies for overhead projector, slides, films, CDs, master copies for drawings and prints, etc. used in each course.

12.5.4 Balanced and Coordinated Program

The various courses shall provide a balanced and coordinated program covering all aspects of the equipment and associated services. The Contractor shall propose an evaluation procedure to assess the effectiveness of the training courses.

The Contractor shall use its best efforts to make available equipment during the manufacture and installation phases in order to facilitate practical training, taking into account the requirements of the overall project implementation schedule.

RSN Technical Specifications

12.5.5 Progress Tests

Progress tests shall form part of the training course and shall be held weekly in order to test the efficiency of the training.

Purchaser reserves the right to communicate deficiencies in the evolution of the training course and to request suitable modifications or the course.

Upon request, the Contractor shall provide an assessment of any trainee.

If required by Purchaser a refresher course will be provided at reasonable cost. At the request of Purchaser, details on the contents of such a course will be provided.

13 Quality Assurance and Factory Inspection

13.1 Quality Assurance Requirements

The Contractor shall be responsible for the Quality Assurance (QA) of all items supplied against the Contract and shall ensure that all the items conform to the required quality.

The Contractor shall provide any information required by Purchaser on the QA procedures that are employed to demonstrate compliance with requirements of this Paragraph.

The Contractor shall be responsible for the QA of all items provided by Sub-Contractors. The Contractor shall provide details (e.g. company's name and the address(es) of the relevant production facilities) of the Contractor's Contractors and manufacturers of all major components and items of equipment.

The Contractor shall state on which standards the QA Procedures are based. The Contractor shall present his status with respect to the ISO 9000 standards.

The Contractor shall nominate a management representative responsible for QA to liaise with Purchaser.

All supporting Quality documentation and specifications will be presented to Purchaser upon request at the relevant manufacturing sites.

13.2 Contractor's Quality Assurance System

The Contractor shall operate an effective method of QA during the design, development, manufacture and installation of all items. The essential requirement is to supply items that will conform to the performance and reliability requirements of the Contract. The Contractor shall ensure that all functions in its Organization are conversant with the QA procedures to avoid relaxation of quality requirements. The responsibility for monitoring the QA shall be independent from production and delivery pressures.

The Contractor shall be free to choose the means which it believes are best to meet the requirements and are best suited to the product, its plants and its organization.

Within two months after contract coming into force, the Project QA Plan shall be provided by the Contractor for approval by Purchaser. The plan shall provide surveillance, monitoring and verification of at least:

- a)** Design and development processes
- b)** Software design, verification, validation and testing processes
- c)** Manufacturing processes, facilities and control

RSN Technical Specifications

- d) Installation and acceptance processes including operating instructions and training of Purchaser personnel

The Quality Assurance procedures must:

- a) By their nature, demonstrate that the items conform to the required quality
- b) Be capable of maintaining an output meeting the requirements of the Contract
- c) Produce quality records on a continuous basis
- d) Be rigorous but flexible enough to cope with day-to-day production problems
- e) Fully safeguard quality at all times
- f) Prohibit the release of items that are known not to conform in all respects to the required quality unless the release of such items is authorized by a formal concession or departure
- g) Provide for overall supervision of the quality control by the Contractor
- h) Be described and documented in a suitable manner (in a Quality manual/Quality plan) to present a clear picture of the method employed to ensure delivery of items of the required quality

The description shall state how, by whom, and with what documents the required quality is to be achieved; general statements will not be accepted.

Non-Conformance Report (NCR): NCRs constitute a key element of the Contractor QA system. A non-conform product may be presented to Purchaser for acceptance if and only if the non-conformance is documented by a NCR. Such product may be used in the System if and only if the NCR is approved by Purchaser.

Documentation will be used by Purchaser during their assessment of QA and shall:

- 1) Be readily available to the Contractor's engineering, production and QA staff for reference on day-to-day working matters
- 2) Show that the staff has the information and authority appropriate to the discharge of their defined responsibilities
- 3) Be the reference for the Contractor's QA manager to ensure that the conditions agreed with Purchaser are being maintained
- 4) Include an organization chart showing staff responsibilities and functions
- 5) Contain a process line diagram showing production operations, inspection and quality monitoring points
- 6) Include a complete description of the quality control methods used
- 7) Define the rules that will determine how product changes are permitted
- 8) Indicate clearly those features of the QA procedures that could be changed without the agreement of Purchaser
- 9) Provide arrangements for the calibration, re-calibration and record of these results

RSN Technical Specifications

- of measuring instruments, jigs, gauges, etc., used during the electrical and mechanical testing of items during any stage of manufacture
- 10) Ensure that valid certificates are held from accredited International Bodies for all factory standards used directly or indirectly by the Contractor or its agent
 - 11) Ensure that material and parts purchased from outside Contractors are manufactured in accordance with QA methods approved by the Contractor and subject to its surveillance. QA procedures of the Contractor shall indicate methods used to ensure the quality level satisfies its own objectives
 - 12) Provide proper segregation of all classes of work (good, scrap, re-work, etc.) at all stages from goods-inward to final dispatch. Segregation and clear identification shall be used to ensure that there is no possibility of misdirection or use of materials, piece-parts or items that are not of the required quality. Handling and storage arrangements shall be such that materials, piece-parts of items are adequately protected from deterioration at every stage of the manufacturing process. Any component used in the final product shall be fully traceable to source of supply
 - 13) Verify that proper training and controls are provided for all personnel together with the tools and environment conducive to achieving the required quality
 - 14) Provide adequate in-line inspection to detect promptly any deterioration in item quality with corrective fast acting feedback loops to prevent items being released that are worse than the required quality
 - 15) Maintain records of inspection processes and the results of such inspection and also provide for the data to be used for the identification and elimination of predominant defects. Statistical trend analysis techniques shall be utilized where appropriate. Copies of all inspection records shall be made available on demand to Purchaser
 - 16) Provide for action to be taken, and Purchaser informed, if the output quality at any stage deviates from the established pattern of variability, not only to correct the cause of the deviation but also to protect the quality of the finished product
 - 17) Ensure that any inspection stage is not required to achieve quality improvement beyond its capability. If the quality of items submitted to a stage of screening is such that the efficiency of that stage is inadequate to ensure that only items of the required quality are released, then a further screening will be necessary
 - 18) Include arrangements for prototypes, "first-offs" production or the like to be subject to review and approval by the Contractor's QA organization and Purchaser Representative
 - 19) Where circumstances demand that submersible plant is manufactured at more than one site, include the following principles:
 - 19.1) Wherever possible, identical plant shall be manufactured simultaneously at all sites. Where simultaneous manufacture is not possible, the test results and QA records of identical plant assembled earlier at other sites from the same batches of

RSN Technical Specifications

- components and raw materials shall be made available to the inspectors when the balance of the plant is manufactured
- 19.2) Individual batches of components or raw materials shall be broken up and evenly distributed between the sites. No one site shall exclusively be supplied with components or raw materials unless the Contractor can clearly demonstrate to the inspectors that such supplies will not result in the products being manufactured at that particular site being different - either electrically, optically or mechanically - from any other identical products being manufactured at other sites
- 19.3) A continuous comparison shall be made by the Contractor of the results of tests carried out at each site on similar circuits, sub-circuits, units and completed assemblies. Any disparity between these results or any divergence in the trends of the results between the sites shall be investigated and a written explanation given to Purchaser Representatives even if the results at all sites are within the contractual specification limits. If the explanation is not considered valid Purchaser reserves the right to withhold Acceptance of such plant from all sites until such time as the Contractor can demonstrate that the plant in question will adequately perform its function for the full twenty five (25) year Design Life of the System
- 20) Allow in-process product identification for defect traceability to a limited batch size
- 21) Provide arrangements for identification, handling, packaging, storage and shipment of products
- 22) Provide the list of raw materials and components showing their origins
- The Contractor shall use a Qualification Program where appropriate to provide assurance to Purchaser that an item is fit for use in a submarine cable. Purchaser may withhold release of items against the Contract if the Contractor fails to provide this assurance.

All item selected for Qualification Testing shall have been manufactured using the methods and techniques used in normal production and inspected and tested to normal QA criteria.

13.3 Quality Assurance Specifications

The Contractor shall provide the preliminary QA Specifications. The full Quality Assurance Specifications shall be submitted for Purchaser acceptance not later than two (2) months before start of manufacture. The Quality Assurance Specifications shall include, but not be limited to, the following:

13.3.1 Quality Assurance of Terminal Station Equipment

- a) Quality standards - General
- b) Quality standards - SLTE
- c) Quality standards - MTE

RSN Technical Specifications

- d) Quality standards - PFE
- e) Packaging, storage and shipment of equipment

13.3.2 Quality Assurance of Repeater Components

- a) List of component types, number of each type used, and origin (with identification of bought supplies)
- b) For each type of components
 - i) Standards, qualification
 - ii) Manufacturing environment
 - iii) Test equipment
 - iv) Selection procedure
 - v) Identification, handling and storage

13.3.3 Quality Assurance of Submersible Repeaters

- a) Standards, qualification
- b) Documentation
- c) Manufacturing environment
- d) Manufacturing operations
- e) Assessment of item quality
- f) fTest equipment
- g) Identification, handling, packaging, storage and shipment

13.3.4 Quality Assurance of Primary Node Components

- a) List of component types, number of each type used, and origin (with identification of bought supplies)
- b) For each type of components
 - i) Standards, qualification
 - ii) Manufacturing environment
 - iii) Test equipment
 - iv) Selection procedure
 - v) Identification, handling and storage

13.3.5 Quality Assurance of Primary Node

- a) Standards, qualification
- b) Documentation
- c) Manufacturing environment
- d) Manufacturing operations
- e) Assessment of item quality
- f) Test equipment
- g) Identification, handling, packaging, storage and shipment

13.3.6 Quality Assurance of Cable Materials Including Optical Fibers

- a) List of raw material and origin
- b) Standards, qualification

RSN Technical Specifications

- c) Quality control of materials
- d) Quality control of optical fiber

13.3.7 Quality Assurance of Cable

- a) Standards, qualification
- b) Manufacturing environment
- c) Manufacturing operation (including fiber splices and factory made repairs)
- d) Quality control of cable (including fiber splices and factory made repairs)
- e) Identification, storage and shipment

13.3.8 Quality Assurance of Cable Joints, Terminations

- a) Product approval
- b) Operator/equipment qualification
- c) Testing equipment
- d) Assessment of quality
- e) Packaging, storage and shipment

A record must be kept of all in-process tests and the results to be available for auditing by Purchaser Representatives.

13.4 Right of Access for Inspection

Purchaser may carry out inspections of the Contractor's QA procedures and their application to the manufacture of components of the System including main raw material provision and Sub-Contractor activities at any time. The Contractor shall supply sufficient details of its factory inspection testing procedures, specifications and results for the acceptance of Purchaser at least one (1) month before the Factory Inspection is performed by Purchaser. The Contractor shall meet reasonable requests made by Purchaser for the accommodation and communication facilities for their representatives, e.g. telephone, facsimile, etc.

Purchaser reserves the right for their representatives throughout all stages of design, development, manufacture, testing and installation to:

- a) Have free and uninterrupted access to the Contractor's premises, and/or that of his Contractors/Sub-Contractors for purposes of auditing at any time during the duration of the contract
- b) Be present at any manufacturing stage, or at any Contractor factory tests carried out during the manufacture of all or any part of the System
- c) Be present at any stage of the System assembly, loading and laying processes
- d) Be present at any Acceptance Test Period
- e) Confirm the Contractor's compliance to the Contractual Quality Plan

If for any reason Purchaser is not satisfied that the agreed system of QA is being operated, or that goods and/or services are not of the required quality, the Contractor will be notified. Such notification shall require the Contractor to take immediate appropriate

RSN Technical Specifications

corrective action. Changes to the agreed system of QA shall only be made with the agreement of Purchaser.

13.5 Release of Items Further To Factory Tests and Post-Installation Tests on Site

At no time shall the Contractor knowingly offer for release equipment that does not conform to the Contract requirements. Subject to the satisfactory completion of all factory tests or on site inspections, Purchaser will certify the fitness for release of a completed equipment or service by the issue of a Release Certificate signed by a Purchaser Representative.

The issuing of such a certificate shall neither absolve the Contractor from its responsibility for meeting the performance requirements of the System nor modify commencement date of the warranty period, nor imply a right to the Contractor to bill in excess of that ordered by Purchaser.

14 Cable Route Survey Activities

14.1 General

This Chapter specifies the requirements and the minimum acceptable standards for conducting the cable route survey.

The Contractor shall in any circumstances be fully responsible for the final selected route, which shall be both economical and viable.

The Contractor will use industry standard equipment which meets or exceeds the requirements.

14.2 General Conditions

14.2.1 Survey Objectives

The main objective of this survey is to confirm or amend the preliminary Cable System route in order to ascertain a suitable route for cable system design, deployment, survivability and subsequent maintenance. The survey will also allow decisions to be made concerning the marine installation procedures, the extent of cable armoring and burial.

Since the survey route cannot be precisely determined prior to the survey, the assessment of the data as it is acquired will determine route deviations from the initially proposed pre-survey route.

The Contractor shall be prepared to perform data acquisition to reasonable endeavors so that an acceptable route can be found. Purchaser and the Contractor will work closely to

RSN Technical Specifications

determine route acceptability where applicable, which in any case remains the Contractor's responsibility.

14.2.2 Contractor's Responsibilities

The Contractor shall be solely responsible for providing and operating all vessels, equipment, charts, personnel and any other items required for the successful completion of the route survey work. The Contractor shall be responsible for successfully fulfilling the electronic route survey objectives and all associated aspects of survey operations, itemized in this document subject to reasonable endeavors

The Contractor shall be solely responsible for obtaining any necessary approvals and permissions for all equipment, procedures, and personnel to fulfil this specification.

The Contractor shall be solely responsible for obtaining all necessary licenses, permits and consents to carry out the work in territorial waters, exclusive economic zones and any other claimed waters.

The Contractor shall arrange with the relevant Authorities for all the necessary licenses, permits and consents required to install navigation chains, including their operating licenses.

The Contractor shall be responsible for customs clearance, publication of intent, permits, consents, licenses, etc. and any applicable duties, taxes and fees for all equipment, supplies and expendables to be used in the survey operations.

In accordance with above permitting responsibilities any associated delays and consequential damages due to difficulties in obtaining customs clearance, permits, consents, licenses, shall be allocated as appropriate. The responsibility of liaising with Authorities, including fishing authorities shall be the sole responsibility of the Contractor.

The proposal shall provide with it a detailed ship schedule for the electronic route survey and describe in detail the scientific survey and navigation equipment and how data will be acquired to meet the survey objectives.

14.3 Survey Scope of Work

The route and shore ends survey shall be carried out by a vessel or vessels, personnel and equipment provided by the Contractor. This shall be complete in all aspects (submarine part and landing points) and shall include, but not be limited to, the survey, measurement, study and investigation of the following:

- a) Desk study by the Contractor including delivery of a report:

A Desk Study report shall be produced and presented to Purchaser in sufficient time before the commencement of survey to enable the survey to commence. This report shall include as much information as feasible on the above items and in

RSN Technical Specifications

particular a recommendation for the proposed route, including specific areas in which more extensive or additional survey coverage would be required.

- b) General bathymetry
- c) Morphology and nature of the sea bottom
- d) Sea bottom and sub-bottom characteristics (such as sand waves, coral reef)
- e) Sea bottom temperatures and seasonal variations taken from publicly available data sources
- f) Surface, sub-surface and sea bed current influences, including convection currents and shelf edge anomalies caused by water temperature and salinity variations taken from publicly available data sources
- g) Seismic activity and turbidity currents in the vicinity of the cable route
- h) Territorial waters and EEZs along the cable route
- i) All types of dump sites (chemical/ industrial wastes, explosives, radioactive materials, cables, etc.) in use or abandoned, or planned (information on planned sites is subject to publicly available data sources)
- j) Fishing activities, dredging activities, submarine resource development (including deep sea mining) and shipping activities (including anchoring and prohibited anchoring area)
- k) Cable fault history
- l) Information relevant to navigation restrictions
- m) Lists of pipelines and cables (power and telecommunication):
 - All existing pipelines and cables in operation and planned along the whole route (information on planned sites is subject to publicly available data sources)
 - All out of use and in operation pipelines and cables in the planned buried sections identified in the desktop study (information on planned sites is subject to publicly available data sources)
- n) Position of known wrecks and other hazards
- o) Information relevant to fish bite risk along the route
- p) Burial requirements

RSN Technical Specifications

- q) Survey operations provisional program
- r) System pre-lay SLD
- s) Marine Installation Procedures

14.4 Survey Plan of Work

The Contractor shall provide a full and adequately detailed SURVEY Plan of Work to support its RFQ. This shall be in Gantt chart form showing Purchaser milestones stated here below, commencing from the date of Contract signature until the delivery of the Final Survey Report. This Plan of Work shall include but not be limited to the following:

- a) Delivery of the Survey Desk Study
- b) Mobilization of the Survey Vessel(s)
- c) Beginning of the survey
- d) Complete survey data acquisition
- e) Demobilize Survey Vessel(s)
- f) Submission of sample charts
- g) Delivery of preliminary charts and report
- h) Acceptance of provisional data
- i) Delivery of Final Charts and Final Survey Report

In addition the Contractor shall specify the activities to be performed, the number of days allocated to each activity, as well as any other information that could help Purchaser to evaluate the merits of its proposal.

14.5 Route Survey Requirements

14.5.1 Methodology

The fundamental aim of the survey is to find the best reasonably practicable route for the installation of the System. As far as reasonably practicable, the route shall be free of excessive slopes, sea currents and obstacles such as wrecks, outcrops, sea mounts, etc., and shall allow for the burying of the cable in the seabed.

The work to be carried out shall include but not be limited to:

RSN Technical Specifications

14.5.1.1 Deep Water Route Survey

For water depths greater than 1500m continuous depth recordings centered along the pre-survey route shall be obtained using a hull mounted deep-sea swath surveying system. In the absence of a hull mounted system, a suitable towed system shall be used

Additional sounding lines may be required to develop any undesirable bottom features that may be encountered.

The minimum swath width required for the proposed route and any additional investigation shall be either 3 times the water depth or 10 km, whichever is lesser. All soundings shall be recorded in meters. The sounders shall have a real time graphic display capable of 50m depth resolution (or better) and bathymetric accuracy 1% of water depth (or better).

Purchaser requires the production of field charts depicting all data acquired at 24 hours intervals to allow route development.

Real time bathymetric data shall be outputted to an X-Y Graphic Representation and shall be properly marked at regular intervals with:

- Project name/number
- Date/time
- Zero settings and calibration

The recordings shall bear, at appropriate regular time and distance intervals, a time mark properly annotated to correspond with a simultaneously recorded ship's position.

14.5.1.2 Shallow Water Route Survey

For water depths from 20 to 1500m or end of burial, a continuous depth recording and side scan imagery shall be obtained along the pre-survey selected route using a swath system with side scan sonar system. A target 500m wide swath from 20 to 100m and a target 1 (one) km wide swath from 100 to 1500m, centered on the proposed route shall be required with a minimum 20% overlap between survey lines. A minimum depth resolution of 0.5% and a bathymetric accuracy of 1.0% of water depth are required.

Additional sounding lines may be necessary to develop any undesirable bottom features that may be encountered.

All soundings shall be reduced to Minimum Low Water Mark (**MLW**), corrected for draft, and recorded in meters. The sounding system shall have a real-time bathymetric display on paper of 10 (ten) meter depth resolution or better.

Comprehensive sub-bottom profiling with adequate resolution to determine the thickness and nature of the superficial sediments in the top 2 (two) meters of the sea bed shall be

RSN Technical Specifications

obtained too.

Seabed samples, as necessary, to confirm the data interpretations of the sediments, shall be recovered. The number and location of the samples will be a field decision made in agreement between Purchaser and the Contractor.

In addition to the above, where the route crosses a known in use cable or pipeline, it may be necessary to carefully determine the location and depth of burial or exposure of the cable or pipeline using the side scan sonar, sub-bottom profiling equipment and/or magnetometer. Use of towed magnetometer equipment deeper than 200 meters water depth may not be feasible and as a result the Contractor may chose to use side scan sonar and/or sub-bottom profiling for the location and burial status of cable and pipe line crossings in those areas. Purchaser may require additional survey coverage at the crossing points to the extent that survey lines are made at 100 meter intervals for a distance of 500 meter on either side of the cable or pipeline.

14.5.1.3 Burial Assessment Survey (BAS)

The objective of the burial assessment survey (BAS) is to assess a route, which has been electronically surveyed and determined its suitability for the simultaneous laying and burial of the submersible plant. This activity is deemed necessary for the portion where burial is intended to be carried out.

It is intended that this survey will provide all necessary information to enable the generation of instructions to assist with the engineering, installation and subsequent maintenance of the submersible plant. The BAS shall provide all necessary information to:

- a) Determine as accurately as possible the burial depth achievable by the selected burial equipment at any position along the route
- b) Determine the appropriate methods of protection throughout the cable route, i.e. plow burial, jetting or trenching and especially the plow up and plow down positions
- c) Predict the wear down of the plow share points and therefore plan the positions where the maintenance of the plow will occur
- d) Provide an estimation of sediment density and shear strength. This will be used to predict burial depths achievable by submersible jetting equipment and assessment of detrenching requirements for subsequent maintenance operations
- e) Predict towing tensions and other associated system installation requirements

14.5.1.3 Activities

The activities along the route to be carried out by the Contractor shall confirm or amend the preliminary route such that the originally outlined objectives are met. The assessment of data as it is acquired may require route deviations from the agreed route.

RSN Technical Specifications

The Contractor will ensure that, as far as possible and practical, the data acquired is not corrupted by the presence of artificial seabed hazards and debris. Where gaps occur in any data category, due to corruption, course deviation or other failure to log valid data, this survey shall be repeated to provide missing or alternative information subject to agreement between the onboard representatives, within 24 hours of the data being provided.

In all circumstances, no towed equipment shall be used within 500 meter of any pipeline or in-service submarine cable.

14.5.1.3.1 Equipment

The Contractor shall fully describe the methods and procedures it intends to use in this operation.

14.5.1.3.2 Remote Operated Vehicle (If Required)

It may be considered necessary for the route, or parts thereof, to be visually inspected during the BAS using a remotely operated vehicle. In such case, records in the form of DVD formats will be required.

The Contractor shall supply technical information of the equipment necessary for this and make recommendations as to how this may be undertaken in the most effective manner.

14.5.1.4 Inshore Route Survey (from MLW to 20m water depths)

An inshore route survey is required for all landing points. The area inshore of the safe working draft limits of the main survey vessel (approximately 20m to the safe working limits of a small craft)) shall be accurately surveyed with a small craft equipped with portable echo sounding equipment. Bathymetry shall be defined in a target 0.5km wide corridor centered along the pre-survey route. Main survey track lines shall run parallel to the preliminary route with a sufficient number of cross check lines spaced at a nominal ten times the parallel line spacing to verify sounding and navigation accuracy. Use of a DGPS to position the boat is suggested.

Side scan sonar, sub-bottom profile surveys are also required.

14.5.1.5 Landing Site Surveys

The landing points shall be definitively positioned by DGPS satellite navigation recorder or other suitably accurate method. The position shall be obtained with the greatest possible accuracy and shall be recorded in WGS 84 geodetic datum.

At the end of activity, the Contractor shall provide the list of all permits/regulations

RSN Technical Specifications

necessary for the marine installation activity and the laying of the land cables as further defined in the System Supply Contract.

The landing site visits shall be done and appropriate local contacts shall be arranged to prepare the survey operation.

14.5.1.6 Equipment

The survey equipment on board the survey ship shall include, but not be limited to the following:

- a) Multi-narrow beam echo sounders
- b) Side scan sonar
- c) Sub-bottom profiling equipment
- d) Bottom samplers, gravity corers, dredges, etc.
- e) Portable precision echo sounder and side scan for near shore route surveys
- f) Any equipment capable of meeting the objectives of the burial assessment survey as described in this chapter, such as a detrenching grapnel, plow tool and core penetration test system

Any other equipment not listed above but available shall be stated.

The Contractor shall submit full technical details of all survey equipment that it proposes to use.

All equipment shall be supplied together with sufficient spares and consumable to ensure their autonomous running.

All equipment shall be tested and calibrated in accordance with the manufacturer's specifications prior to the commencement of operations to ensure proper working order.

14.5.1.7 Side Scan Sonar

Where water depth is less than 1500m or at the end of burial a side scan sonar shall be used to search both sides of the track to assist in the location and extent of wrecks, outcrops etc., and to provide data for the sea bed description.

The final recommended route shall be clear of all obstructions by at least 250m on either side unless otherwise stated however in certain areas, such as congested inshore areas or in congested cable corridors this may not be practical.

The side scan shall include an accurate positioning system to determine the position of the towed body.

RSN Technical Specifications

14.5.1.8 Sub-Bottom profile, and Bottom Samples

Sub-bottom profiler equipment shall be used during the route survey and shall provide data on the nature of the sedimentary layers at least in the top 2 (two) meters of the sea-bottom.

Bottom samples, gravity corers, grab samplers, dredges, etc., shall be obtained. The Contractor shall make use of the sub-bottom profiling equipment in making decisions on the locations for the bottom sampling.

Sufficient bottom samples shall be taken to supplement the side scan and the sub-bottom profiling equipment data in determining the nature of sub-bottom material and the technical feasibility of cable burial. A maximum of 35 samples has been included

Each core sample obtained shall be longitudinally split and photographed in color. A scale in centimeters and a photographic identification number shall be legibly shown in each photograph. Clay units or clay composite units present in each core shall be tested by a hand-held torvane instrument to determine shear strength at as many layers as possible.

Vertical stratigraphic core cross sections (core log), torvane results, photographs and sediment descriptions shall be provided as an appendix to the final narrative report.

Vertical stratigraphic cross sections of each core along with sediment descriptions and torvane measurements shall be plotted on the final geomorphologic charts and cross-referenced to the photograph/ core identification number. Cross hatching and shading shall be used to differentiate the various sediment types on the stratigraphic cross sections. The vertical scale for the stratigraphic cross sections shall be 1:10 (10 cm of core to 1 cm of drawn cross section).

Grab samples, dredges, etc. shall also be photographed in color and photograph identification number shall be shown in each.

Each sample shall be fully described on both the final geomorphologic charts and as appendix to the final narrative report.

All samples (cores, grabs, dredges, etc.) may be discarded following analysis and photography; however, the Contractor shall assume full responsibility for the quality, clarity and control of the photographic film and descriptive data obtained from each sample after it has been discarded.

14.5.1.9 Current Meters (optional)

Current meters have not been included but may be included as a contract variation subject to availability.

RSN Technical Specifications

14.6 Survey Vessels and Personnel

The sea survey shall be carried out by a suitable vessel or vessels adequately equipped for this operation and submitted for the approval of Purchaser which shall not be unreasonably withheld.

The Contractor shall provide full details of the operating characteristics and capabilities of the vessel in its proposal.

This description shall include but not be limited to:

- a) Name of the Vessel
- b) Flag
- c) Call sign
- d) Total length
- e) Breadth
- f) Draught
- g) Endurance (days between port calls for refueling or provisioning)
- h) Fuel and fresh water capabilities
- i) Berthing facilities
- j) Cruising and survey speed
- k) Main propulsion unit and auxiliary equipment
- l) Standard bridge navigation and vessel control equipment
- m) Laboratory space and power supply available for chart work, computer operation and data reduction
- n) Operating drafts limits
- o) Accommodation facilities available to the representatives
- p) Previous survey experience
- q) Telephone and data telecommunication facilities available on board
- r) Ship to have adequate equipment able to reproduce documents. This facility shall be provided free of charge to Purchaser Representatives which may vary according to the vessel used
- s) In addition to the Contractor's personnel, accommodation shall be available for up to 2 representatives of Purchaser

The qualification shall specify, as far as possible, the specific wind, weather and sea conditions that would force curtailment of the survey operations. The Beaufort wind scale and the sea state codes shall be used for fulfilling this requirement. The vessel master shall be responsible for determining safe and practical working conditions which may vary from those stated.

RSN Technical Specifications

The qualification of key vessel and survey personnel shall be included as an appendix to the proposal. Purchaser requires a resume on such personnel that shall include professional qualifications, previous experience with the systems to be used, and a general background of the persons concerned. Purchaser reserves the right to reject, or have replaced, any personnel offered without additional costs subject to specific cause and after agreement with Contractor.

14.7 Purchaser Representation

Accommodation and sustenance shall be provided on board the cable survey ship for up to two Purchaser Representatives for the entire duration of the survey at no extra charge. In the event that special dietary requirements are requested by Purchaser representatives, this requirement shall be made known to the Contractor one month before the survey works and shall be provided at no extra charge and subject to availability.

Each Purchaser Representative shall be entitled to two free daily telephone and facsimile communication per satellite, or cable if available. In cases of emergency or in critical situations, unlimited communications facilities shall be granted.

In case of two Purchaser Representatives, they will nominate among them a Senior Purchaser Representative, which will be the official point of contact for the Contractor during the marine operations.

Communication facilities internal to the ship shall be provided by agreement with the Senior Purchaser Representative. This will normally consist of a cabin telephone extension and a facility to monitor operations communication channels. Facilities may vary according to the survey vessel used-

Office facilities shall be provided for use of the Senior Purchaser Representative comprising desk space, document storage and facilities to allow operation of a personal computer and printer in conditions where confidentiality of work in progress can be maintained.

Facilities to allow work to be carried out on fully spread survey charts shall be provided for use by Purchaser Representative(s). The facilities may vary from survey vessel to survey vessel and all the items listed above may not be available.

14.8 Navigation and Positioning Equipment

The Contractor shall utilize surveying equipment and systems in accordance with the proper hydrographic surveying principles, and shall assure that no ambiguity will occur in the position of the vessel, fix points, or features to be surveyed and logged.

The Contractor shall provide notice to Purchaser of operational timings as soon as is practicable to facilitate the attendance of Purchaser representatives.

RSN Technical Specifications

Prior to commencement of the operations, the Contractor shall test and calibrate each component of the navigation system to be used to ensure proper working order.

Purchaser requires a 24 hours/day positioning system with a DGPS primary navigation system used for all survey phases. A back-up positioning system shall be made available during the survey operation that shall be either a second DGPS or any other positioning system with the similar accuracy such as Trisponder, Syledis, etc.

The Contractor shall describe its proposal for a primary navigation system for these works.

14.9 Additional Equipment

Purchaser requires that the Contractor provides a software system with the capability to accept and store the multi-parameter survey data, for both a real-time display and for subsequent reduction and post processing. These data shall include, but not be limited to, navigational and bathymetric data, and real time clock and vessel gyro compass inputs.

14.10 Equipment Maintenance, Operation and Downtime

The Contractor shall ensure that downtime (absence of data acquisition) due to equipment malfunctions is kept to a minimum. Adequate spare parts and components and qualified maintenance technicians shall be available throughout the survey.

The Contractor shall be responsible for all system calibration and re-calibration, including spare equipment.

14.11 Survey Report

A detailed final narrative report shall be prepared by the Contractor to supplement and explain thoroughly the data presented on the charts. This shall include amendments, where applicable, to the desk study.

The final route survey report shall include but not be limited to the following:

Part 1 Description of the proposed cable route

- a. List of geographical co-ordinates in accordance with the following:
 - Purchaser proposed route
 - Pre-survey selected route
 - In field selected route
 - Post survey agreed route
- b. All sounding charts, showing the survey ship's tracks, contoured and logged during the survey operation

RSN Technical Specifications

- c. North up survey charts with the proposed cable route and with indication of the bathymetry and of the existing and planned cables and pipelines
- d. Sea bed characteristics, sediment types and sub-bottom structure
- e. Burial feasibility

Part 2 Physical study of the cable route areas

- a. Morphology of the sea bottom and geological constraints along the cable route
- b. Sediments of the continental shelves
- c. Sea bed temperatures and their predictable variations taken from publicly available data sources
- d. Ocean currents (surface and bottom) and tide, with seasonal variations taken from publicly available data sources
- e. Weather and its possible impact on cable laying
- f. Seismology
- g. Cable Shore end studies

Part 3 Human activity

- a. Fishing and trawling activities (types of ships, species collected, fishing seasons)
- b. Maritime traffic
- c. Off-shore oil and gas activities
- d. Navigation restrictions, wreck positions
- e. Submarine resources development
- f. Dumping areas (with associated charts as available from public sources))

Part 4 Fault history

- a. Existing and abandoned cables and pipelines (with associated charts as available from public sources))

RSN Technical Specifications

- b. Assessment of fish bite risk with clear indications of the areas (if any) along the proposed route where the cable could be exposed to such risk
- c. Cable fault history on abandoned and existing cables (with associated charts as available from public sources))

Part 5 Marine survey

- a. Extracts from ship's diary
- b. Satellite fixes to appear clearly on survey charts
- c. Side Scan data, seismic data and interpretation
- d. Description of survey stations (temperature and current measurement if taken, bottom samples and pictures)

Part 6 Conclusions and recommendations

- a. Recommended cable route
- b. Recommended cable types
- c. Recommended cable slack
- d. Recommended overall SLD

14.12 Delivery and Review / Approval of Reports

14.12.1 Provisional Survey Report

This provisional report shall include the following:

- (i) A narrative overview of the main results of the electronic route survey and scientific data updating the desk study.
- (ii) List of the following geographical co-ordinates:
 - Purchaser proposed route
 - Pre-survey selected route
 - In field selected route
 - Post survey proposed route
- (iii) Draft charts as defined in part 1 (c) of the survey report
- (iv) Draft of the part 6 of the survey report

Any modifications from the Pre-survey selected cable route shall be substantiated with data acquired during the electronic route survey. The provisional report including charts

RSN Technical Specifications

and profiles shall be marked as "PROVISIONAL". The charts and profiles may be delivered rolled, not folded, in addition to the electronic format.

The provisional report shall be submitted to Purchaser within 30 calendar days of the completion of the survey activities for review, comment and approval. Purchaser approval will be notified within 4 weeks of receipt or within a period to be mutually agreed.

14.12.2 System SLD

As part of the Provisional Survey Report, a Pre-lay Submarine Cable Route and a Pre-lay System SLD shall be submitted by the Contractor, taking into account:

- (1) The results and recommendations of the survey
- (2) The slack assignment proposed by the Contractor or as given in the Contract

The final cable route, cable types and lengths and the lengths of buried cable shall be as close as possible to the route and SLD of the Contract. The final route and SLD shall be mutually agreed between Purchaser and the Contractor.

If the parameters included in the final System Optical Power Budget are better than those indicated in the Contract, the optical power margins of each repeater section may be increased or/and any repeater(s) in excess may be included in the System spares or/and withdrawn from the Supply list according to the decision of Purchaser.

If these parameters are not as good as those indicated in the Contract, the optical power margins in each repeater section shall not be decreased and any additional repeater required to comply with the optical power margins requirements shall be provided by the Contractor at no extra cost to Purchaser.

14.12.3 Final Survey Report

The final survey report shall be presented to Purchaser within 120 calendar days of the approval of the provisional survey report.

The final report shall be provided in electronic format.

15 List of Abbreviations

AC	Alternating Current
A/C	Alteration of Course
AIS	Alternate Insertion Signal
AM	Amplitude Modulation
AMS	Alternate Maintenance Signal
BAS	Burial Assessment Survey
BBER	Background Block Error Rate
BER	Bit Error Rate
BMH	Beach Man-Hole
CBL	Cable Breaking Load
CD	Chromatic Dispersion
CR	Conductor Resistance
CTE	Cable Terminating Equipment
CWDM	Coarse Wavelength Division Multiplexing
DA	Double Armored cable
DC	Direct Current
DGPS	Differential Global Positioning System
DLS	Digital Line Section
DSF	Dispersion Shifted Fiber
DWDM	Dense Wavelength Division Multiplexing
EDFA	Erbium Doped Fiber Amplifier
e.g.	exempli gratia
EM	Element Manager
EMS	Element Management System
EMI	Electro-Magnetic Interference
ESD	Electro-Static Discharge
ETSI	European Telecommunications Standards Institute
FERF	Far End Receive Failure
FBL	Fiber Breaking Load
FM	Frequency Modulation
Gbps	Gigabit per second
GUI	Graphical User Interface
GPS	Global Positioning System
HCI	Human Computer Interface
i.e.	id est.
IEC	International Electro-technique Committee
IR	Insulator Resistance
ISO	International Standardization Organization
ITU - T	International Telecommunication Union - Telecommunications Standardization Sector
kN	kilo-Newton
KP	Kilometer Point
LW	Light Weight cable

RSN Technical Specifications

LWA	Light Weight Armored cable
LWP	Light Weight Protected cable
MC	Maintenance Controller
MLW	Minimum Low Water
ms	milli-second
MTBF	Mean Time Between Failures
MTE	Management sub-system Terminal Equipment
MTFF	Mean Time to First Failure
MTTR	Mean Time to Repair
NE	Network Element
nm	nanometer
NMS	Network Management System
NOTS	Nominal Operating Tensile Strength
NPTS	Nominal Permanent Tensile Strength
NTTS	Nominal Transient Tensile Strength
ODF	Optical Distribution Frame
OF	Optical Fiber
OFA	Optical Fiber Amplifier
OADM	Optical Add Drop Multiplexer
OA&M	Operation, Administration and Maintenance
O&M	Operation and Maintenance
OOI	Ocean Observatory Initiative
PA	Provisional Acceptance
PFE	Power Feeding Equipment
PSBU	Power Switched Branching Unit
PSTN	Public Switching Telephone Network
QA	Quality Assurance
RA	Rock Armored cable
RDI	Remote Defect Indication
RFPA	Ready For Provisional Acceptance
RFQ	Request For Quotation
RMS	Root Mean Square
RPL	Route Position List
RSN	Regional Scale Node
SA	Single Armored cable
SDH	Synchronous Digital Hierarchy
SLD	Straight Line Diagram
SLTE	Submarine Line Terminating Equipment
SLLI	System Loading and Laying Instructions
STM	Synchronous Transmission Module
TMN	Telecommunications Management Network

RSN Technical Specifications

TSE	Terminal Station Equipment: (a) Cable Terminating Equipment (CTE) (b) Terminal Transmission Equipment (TTE) including multiplexers and demultiplexers (c) Power Feeding Equipment (PFE) (d) Management Terminal Equipment (MTE)
TTE	Transmission Terminal Equipment
UJ	Universal Joint
UJ	Universal Joint Contractors
Consortium	
UTM	Universal Transverse Mercator
w.a.	when/where applicable

END OF DOCUMENT