



OCEAN
OBSERVATORIES
INITIATIVE

OPERATIONS AND MANAGEMENT PLAN

Version 3-01
Document Control Number 1010-00000
17-Dec-2021

Woods Hole Oceanographic Institution
266 Woods Hole Rd, Woods Hole, MA.

in Cooperation with

University of Washington
Woods Hole Oceanographic Institution
Oregon State University

Document Control Sheet

Version	Date	Description	Originator
1-02	Nov 29, 2007	Initial integration for PDR	R. Lunde
1-03	Sep 30, 2008	Re-titled, updated, and edited	J. Christman
1-04	Oct 18, 2008	Added EPE/QA section wording	H. Given/J. Christman
1-05	Oct 21, 2008	Added Pioneer site move process	J. Christman
1-06	Oct 28, 2008	Modified Intro, Appendix A-4	L. Brasseur
1-07	Oct 29, 2008	Formatting	L. Snow
1-08	Oct 29, 2008	EPE section, wording	S. Banahan/ L. Brasseur
1-09	Jun 18, 2010	Add NSF required sections	M. Goodnight
1-10	Jul 26, 2010	Edits and reorganization	M. Goodnight / T. Cowles
1-12	Nov 10, 2010	Review and update	O&M Team (San Diego)
1-13	Nov 16, 2010	Edits and updates	T. Cowles / E. Griffin
1-14	Apr 18, 2011	Review and Update Document Structure, Transition to Ops, Governance	O&M (CGSN, RSN, CI, PMO)
1-16	Apr 22, 2011	Candidate pending ECR 1301-00015	R. Novack
2-01	Aug 11, 2011	Restructured document format and contents to add Integrated Logistics approach	M. Antonucci / S. Ashaari
2-02	Aug 27, 2011	Updated draft Plan to incorporate comments received from CI, CGSN and RSN	M. Antonucci
2-03	Aug 31, 2011	Updated draft Plan incorporating comments received from S. Ashaari, S. Banahan. Logistics Lite.	M. Antonucci / S. Ashaari
2-04	Sep 1, 2011	Updated draft Plan incorporating CGSN Comments and ILS Lite	M. Antonucci
2-05	Sep 2, 2011	Cleaned up formatting	M. Antonucci
2-06	Sep 9, 2011	Edits to make OOI centric	R. Novack / M. Antonucci
2-07	Sep 14, 2011	Incorporates breakout session inputs. Modified text in section 3	M. Antonucci / S. Ashaari
2-08	Sep 14, 2011	Modifies text in 4.1.1 and 8.2.1.2	M. Antonucci
2-09	Sep 22, 2011	Additional edits to make OOI centric. Changed outline.	M. Antonucci
2-10	Sep 23, 2011	Inserted OL/IO rewrites (paragraphs 7.0, 7.1, 8.2.3.1, 8.4)	M. Antonucci
2-11	Oct 14, 2011	Formatting, copy edits	E. Griffin
2-12	Nov 4, 2011	Updated transition to operations, data management	M. Antonucci
2-13	Nov 18, 2011	Updated governance, updated texts in Sections, 2, 3, 6 & 7	T. Cowles / M. Antonucci / S. Ashaari
2-14	Nov 18, 2011	Updated Sections 3 & 6,	M. Antonucci / S. Ashaari
2-15	Nov 21, 2011	Formatting	E. Griffin
2-16	Dec 9, 2011	Incorporate comments from ECR 1300-100219; Unresolved liens will be addressed in next update.	M. Antonucci
2-17	Jan 26, 2012	Formatting	E. Griffin
3-00	Jun 2, 2021	Update for OOI 2.0 Comments captured in ECR-587	P. Matthias, L. Slicer, J. Glatstein, M. Palanza, S. White, J. Fram, B. Ittig, D Buffitt, D. Trew-Crist

3-01	Dec 15, 2021	Add MIO data flow diagrams, various CI updates, add reference to MoN Guidance	M. Palanza, Brian Ittig, Jon Fram, D. Buffitt
------	--------------	---	---

Table of Contents

Contents

1	Executive Summary	1
2	Purpose and Scope.....	1
3	Management Functions.....	2
3.1	Program Management Structure	2
3.2	Organization & Governance	2
3.3	Regulations and Guidelines.....	2
3.4	Financial and Subaward Monitoring	3
3.5	OOI Cross-Project Coordination.....	4
3.6	Program Engineering.....	5
3.6.1	Configuration Management.....	5
3.6.2	OOI Performance Metrics	5
3.6.3	Risk and Opportunity Management.....	6
3.6.4	Vendor Quality Issues.....	6
3.6.5	Mitigation of Obsolescence / Aging Components	6
3.6.5	Continual Improvement Process/Technical Refresh	7
3.7	Cyberinfrastructure	7
3.7.1	CI Management Execution	7
3.7.2	Software Release Process	7
3.7.3	Cybersecurity.....	7
3.7.4	System / Equipment Monitoring.....	8
3.7.5	HelpDesk Support.....	8
3.8	Community Engagement Management.....	10
3.9	OOI Opportunities for the Science Community	10
3.10	Process for Adding Instruments	10
3.11	Process for Modifying Instrument Sampling.....	12
3.12	Process Reviewing Deployments in OOI-permitted Areas.....	12
3.13	Process for Loaning OOI Equipment.....	13
3.14	Pioneer Array Relocation.....	13
3.15	Unplanned Event Management	14
3.16	Environmental, Health & Safety.....	14
3.17	Annual Work Plan (AWP) Process	15
3.18	Assumptions Supporting Schedule and Budget	15
3.19	Approach to Cost Escalation	16
3.20	Science Oversight Committee (SOC).....	16
4	Marine Implementing Organization Management and Operations	16
4.1	MIO O&M Management.....	17
4.2	MIO Common Operations.....	17
4.3	MIO Operations	17
4.3.1	Refurbishment	18
4.3.2	Installation Readiness.....	20
4.3.3	O&M Field Operations	20
4.3.4	Scheduled Field Operations	21
4.3.5	Unscheduled Field Operations	21
4.3.6	Array Operations.....	22
4.3.7	Array Data Telemetry.....	22
4.3.8	RCA Data Flow	23
4.3.9	CG Data Flow	24
4.3.10	EA Data Flow	25
4.3.11	Array Post Recovery.....	25
4.3.12	Array General Activities	25

4.4	CI Operations.....	26
4.5	O&M Data Management.....	26
4.6	OOI Trouble Reporting	26
4.7	Data Product Management.....	27
4.8	Supply Support Management.....	27
4.9	OOI Science User Support Procedures.....	29
4.9.1	MIO Scientific Investigator Planning.....	29
4.9.2	MIO Project Scientist Team.....	29
4.9.3	MIO Engineering Team.....	30
4.10	MIO Quality Assurance / Quality Control.....	30
4.10.1	Coastal / Global Scale Nodes and Endurance Array.....	30
4.10.2	Regional Cabled Array	30
4.11	OOI Support Facilities.....	30
4.11.1	RCA Facilities.....	30
4.11.2	CGSN Facilities	32
4.11.3	EA Facilities.....	33
	Appendix A: Acronyms	34
	Appendix B: Reference Documents	36

1 Executive Summary

The Ocean Observatories Initiative (OOI) is an interactive, globally distributed, and integrated infrastructure of science-driven instruments enabling interdisciplinary ocean science. The OOI networked infrastructure collects and delivers ocean, seafloor, and atmospheric measurements for an intended life span of 25 years. The transformational near-real-time capabilities of the OOI infrastructure provide users with simultaneous, collocated, and interdisciplinary measurements to investigate and respond to a spectrum of phenomena including episodic, short-lived events (earthquakes, volcanic eruptions, hypoxia, severe storms), and subtler, longer-term changes, or emergent phenomena in ocean systems (circulation patterns, climate change, ocean acidification, ecosystem trends).

The OOI Program has transitioned through design, build, and deployment since its inception in 2009. The OOI Infrastructure was formally commissioned and accepted in 2016. Since 2016, the Program has been in an Operations and Management (O&M) phase that includes deployment/recovery of elements of the OOI infrastructure, refurbishment, and data collection, delivery, and display.

The OOI Marine Infrastructure consists of five active and two inactive arrays managed by three organizations. The Coastal Pioneer Array and the Global Station Papa and Irminger Sea Arrays are managed by the Coastal Global Scale Nodes (CGSN) group at Woods Hole Oceanographic Institution (WHOI). CGSN was also responsible for the operations and management of the inactive Global Southern Ocean and Argentine Basin Arrays. The Regional Cabled Array (RCA) is managed by the University of Washington. The Coastal Endurance Array is managed by the Oregon State University (OSU).

The observatory system consists of cabled and uncabled platforms at multiple locations, with each platform designed to support a broad variety of instruments, connected and controlled via a sophisticated communication and computation framework. The fixed infrastructure is augmented by mobile platforms that provide additional spatial coverage to the network. A detailed description of the OOI infrastructure is provided at the public-facing OOI website, oceanobservatories.org.

2 Purpose and Scope

This OOI Operations and Management (O&M) Plan establishes the management approach, responsibilities, processes, and execution strategy for O&M of the OOI system. The Program Management Office (PMO) at the Woods Hole Oceanographic Institution (WHOI) and the Implementing Organizations (IOs) use this plan to guide operations, management, communications, governance, and policy setting. This document identifies how the Program activities are coordinated and integrated among the IOs and the PMO to produce quality data products to the user community.

The strategic goals of this plan are to (a) describe the governance and execution of operations that contribute to the maximum availability of high-quality data from all elements of the OOI, and (b) ensure future system expansion capabilities (e.g., marine instruments and functionality) for the user community. The OOI's transformative capabilities provide sustained near-real-time observations of multiple parameters and processes in the atmosphere, ocean, and seafloor via an infrastructure that can be extended and expanded in response to the evolution of social and scientific priorities over the twenty-five-year lifetime of the project.

3 Management Functions

3.1 Program Management Structure

OOI O&M requires continuous monitoring and controlling of daily O&M activities to respond to both the short and long-term needs of the OOI infrastructure. OOI O&M operates within a fixed annual budget cycle allocated to specific tasks that align O&M planning with available funding.

Each O&M program year begins in October with an NSF-approved budget and Annual Work Plan (AWP). Throughout the year, AWP milestones and scheduled tasks are executed and the performance of each is tracked and reported. Day-to-day management of the OOI is performed by the individual IOs for their portion of the system with oversight provided by the Program Management Organization (PMO).

Coordinated management oversight is led by the PMO and supported by continuous communications among O&M managers and O&M personnel working on cross-system issues. Communications among O&M personnel include addressing technical issues related to operations and management and identifying more efficient processes and procedures for the sustainment of the OOI system.

A review by the NSF is conducted each year to evaluate the current year's performance of the OOI. In addition, the review evaluates plans and budgets for the upcoming year. Performance evaluation and recommendations are two of the products of an NSF Review used in the planning steps for the upcoming year.

Each year, based on the work that must be done to sustain the OOI, the PMO and the individual IOs validate their cost and schedule for each of their Work Breakdown Structure (WBS) elements in the AWP, and document this information in detailed Cost Books. They update their forecasts to reflect changes needed in staffing levels, labor categories, and any other factors that require adjustment within each WBS. These updates and the corresponding Cost Books provide the quantitative financial basis for the O&M AWP for the coming year.

OOI addresses the sources of variability in costs from year to year. Equipment that wears out or deteriorates faster than expected and must be replaced or addressed with major refurbishment is one source of variation in annual costs. Some durable elements (e.g., the RCA cable, the buoy hulls of the CGSN) have long expected lifetimes, while other elements wear out or require replacement due to obsolescence in a few years. In addition, ship scheduling may result in two global cruises to a given site in one 12-month period and none in the next.

During operations, unpredicted catastrophic failure of OOI platforms (e.g., loss of an entire mooring, cable failure due to fishing activity), and weather delays can result in unexpected demands that exceed the annual O&M budget that may need to be addressed by descopeing for a given year.

3.2 Organization & Governance

Organization and Governance are captured in the OOI CONOPS Document Control Number (DCN) 1012-00000.

3.3 Regulations and Guidelines

The OOI is a federally-funded Major Facility of the National Science Foundation and awarded via a Cooperative Agreement. The OOI is subject to the following federal guidelines, regulations,

and related documents that define the requirements for activities, program management, and expenditures of federal funds.

- The Federal Awarding Agency's terms and conditions and policies, including revisions, and addenda in effect as of the beginning date of the period of performance, or as amended by legislation or regulation noted on the Federal Awarding Agency's website: [NSF Award Search: Simple Search](#).
- Uniform Administrative Requirements, Cost Principles and Audit Requirements for Federal Awards (Uniform Guidance), 2 CFR Part 200 as applicable, [Electronic Code of Federal Regulations \(eCFR\)](#), and also provided as Overlay to the Uniform Guidance at Research Terms and Conditions in effect as of the beginning date of the period of performance, or as amended thereafter: [Awards - Federal-Wide Research Terms and Conditions | NSF - National Science Foundation](#).
- The Federal Awarding Agency's Cooperative Agreement Financial and Administrative Terms (CAFATC), and the Cooperative Agreement Modifications and Supplemental Financial and Administrative Terms and Conditions (CAFATC Modifications & Supplemental) for Major Multi-User Research Facility Projects and Federally Funded Research and Development Centers, including addenda in effect as of the beginning date of the period of performance, or as amended thereafter: [Awards - Cooperative Agreement Conditions | NSF - National Science Foundation](#).
- The Federal Awarding Agency's Major Facilities Guide (formerly the Large Facilities Manual), Business Systems Review Guide, and other applicable documents of the Agency's Large Facilities Office, in effect as of the beginning date of the period of performance, or as amended thereafter: [Office of Budget, Finance, and Award Management: Facilities Documents | NSF - National Science Foundation](#).
- The Federal Awarding Agency's Proposal & Award Policies and Procedures Guide (PAPPG), in effect as of the beginning date of the period of performance, or as amended thereafter: [PAPPG Introduction \(nsf.gov\)](#).
- Other requirements that may be adopted after the date of this document.

The OOI PMO proposes, institutes, and maintains OOI operation policies and procedures in coordination with the NSF, to formalize accountability, ensure compliance with agreements and regulations, and standardize processes across OOI. A formal Policy review and approval process is implemented through the approved policies maintained in the OOI Document Control System as detailed in the OOI Configuration Management Plan, DCN 1000-00000.

Procedures identify processes by which policies are implemented. Generally, procedures are developed by the organization that must implement the policy and be approved by the policyholder. Samples of the kinds of processes/procedures that may fall under the purview of the IOs are listed in section 4.2.

3.4 Financial and Subaward Monitoring

In consideration of requirements outlined in the Uniform Guidance and other regulatory/compliance documents, the WHOI PMO employs a comprehensive financial monitoring structure which includes the following:

- Business Systems Reviews of Sub-awardees.
- Detailed monthly invoice and supporting documentation requirements.
- Memorandum of Negotiation (MoN) status and procurement plans.
 - OOI 2.0 guidance for MoN requirements are detailed in the memo: "Memo re MoN Interpretation and Guidance FINAL 10-4-2019.pdf" located in: <https://jira.who.edu/browse/ECR-234>

- Monthly Tracking Books and other analyses which address accomplishments, risks, opportunities, obstacles, budget/scope changes, and projections for estimate-to-completion and estimate-at-completion for a given project year.

3.5 OOI Cross-Project Coordination

During the lifecycle of the OOI, purposeful cross-project functional teams are formed and budgeted as required, to address specific O&M activities. These cross-project teams support the use of consistent and uniform processes and procedures throughout OOI. O&M teams are formed with well-defined goals, and deliver a pre-defined explicit set of deliverables, such as risk mitigation plans or new program procedures. These collaborations are initiated by the PMO or Marine Implementing Organizations (MIOs), as appropriate, and are vital to delivering best practices and efficient operations.

At the highest level, these collaborations support the goal of delivering the highest quality science products, safely, at the lowest possible operating cost. In doing so these collaborations include the following attributes:

- Develop procedures collaboratively with subject matter experts
- Establish common procedures across IOs
- Create sustainable O&M processes for the field operations of the MIOs
- Create a culture of continuous process improvement
- Provide clear objectives and governance for O&M

Initiation of the collaborative tasks is predicated on quantifying resources needed to (a) accomplish the stated goal and (b) produce the deliverables within the approved schedule. If any part of the work performed is outside scope, then a funding source for the additional scope is secured from outside the Program.

Proper coordination of the cross-project functional activities by the PMO is particularly vital to ensuring efficiency of operation and minimizing material cost expenditures. This coordination is realized by a combination of ad hoc and permanent cross-MIO teams organized according to defined objectives. Ad hoc teams may be formed to address cruise support, refurbishment and calibration, business processes, or other common concerns. The objectives and types of “permanent” cross-project functional teams are provided in Table 1.

Cross-Project Team	Measures of Effectiveness	
	Common Objectives	Specific Objectives
Data Team	Lessons Learned Commonality Transformative Best Practices Transparency Mentoring	Documented Data evaluation information, and support for metadata, ingestions, data reviews, and data quality.
Instrument Working Group		Prioritization of instrument issues. Cross-MIO support to Vendor relations and Engagements. Includes instrument troubleshooting, technical refresh.
Engineering Team Reviews		Establishment of new procedures, trade studies. Includes reviewing potential design updates, performing failure analyses, supporting performance reviews.
Program Management Team		Support weekly meetings, discussion of issues. Review of Tracking Books, including risks and opportunities, spending, and budgeting. Coordination/reporting of Program activities take place at this level including any cross-MIO support.
PI/PS Team		Science Developments and Opportunities.
Change Control Boards (CCB)		Document and gain approval for design and budget changes, System Level CCB's: 39, System Level ECR's: 79
Quarterly Data-Driven Reviews		Ad hoc working groups with a representative from each IO. Supports ongoing self-assessment and continuous improvement.
Glider Team		Cross-MIO Vendor Engagement.
CG/EA Engineering		Communicating need dates aids in meeting cruise timelines.

Table 1. OOI Permanent Cross-Project Functional Teams

3.6 Program Engineering

The OOI Program Engineer coordinates OOI engineering activities defined in the Systems Engineering Management Plan, DCN 1100-00000, and with the support of the IOs, provides the functions described in the subsections below.

3.6.1 Configuration Management

The OOI Program Engineer oversees the OOI Configuration Management process, chairs CCBs, and reviews and approves changes to the OOI configuration. The PMO is responsible for conducting periodic configuration audits of the OOI to ensure that current versions of configuration drawings are being used and that the drawings represent an accurate portrayal of the OOI. The OOI Program Engineer is responsible for ensuring that the deployed assets are synchronized with the infrastructure drawings and requirements.

IOs ensure that the configuration of the hardware and software they are responsible for conforms to the system baseline documentation and any approved exceptions or changes. Configuration Management maintains the approved system baseline for both hardware and software. Deviations from the baseline, such as equipment failures between equipment turns, are tracked as system issues in Redmine to be resolved, or to provide the impetus for review of the existing baseline and approval of necessary changes.

Program Configuration Management is described in the OOI Configuration Management Plan (CMP) DCN 1000-00000.

3.6.2 OOI Performance Metrics

OOI Management Performance Metrics include cost and schedule against the AWP, and number, disposition, and implementation of ECRs. OOI Systems Performance Metrics include:

- Actual deployments of platforms and sensors against the AWP
- Status of deployed platforms and sensors
- Availability of full deployed science and engineering data sets, including streaming, telemetered, and post cruise
- Data availability by instrument, platform, array, and CI data delivery
- Data volume by instrument, platform, and array
- Telemetry, including total connection events by platform telemetry system, mean connection interval by platform, and total telemetry usage by month

OOI Usage Metrics include:

- Number of new and returning users per month
- Number of datasets streamed or downloaded per month
- Downloads by instrument type and location
- Number of page views
- Average page load times
- User satisfaction surveys
- Redmine Tickets, including number of Tickets per month, median time to close Tickets, and number of Tickets open more than 30 days.

3.6.3 Risk and Opportunity Management

The OOI Program maintains a Risk Register in a Jira-based Risk and Opportunity Management Application that supports all aspects of the OOI Risk and Opportunity Management process as defined in the Risk and Opportunity Management Plan, DCN 1007-00000. As OOI risks and opportunities are identified, they are entered into the Jira “RISK” Management Application. The application supports the management, and tracking of all risks and opportunities through their individual life cycles. Management includes activities such as Risk and Opportunity Management Board (ROMB) meetings, changes in risk/opportunity status, and generation of reports.

3.6.4 Vendor Quality Issues

Vendor quality issues are identified by the cross-MIO working groups, data from the Marine Infrastructure tracking in Redmine, or from individual OOI personnel. Mitigation issues are initiated at the MIO level, and tracked in the Risk Register. Issues can be escalated to the PMO for support as needed.

3.6.5 Mitigation of Obsolescence / Aging Components

OOI uses several management functions to identify obsolescence-related issues and take remedial actions to prevent shortages on the OOI program during Steady State. The objective is to identify manufacturing end-of-life dates before they occur and to consider committing to lifetime buys to procure materials that are needed for future use, or conduct redesign to address obsolete items. These approaches help prevent repair and refurbishment-related delays due to material shortages. Other management actions include identification of alternate supply sources, special agreements with manufacturers to resume production, and service agreements with vendors and suppliers. Component obsolescence requires replacement of components and documentation updates. When a direct replacement is not available, engineering teams evaluate and select an alternative that meets requirements.

To deliver the highest quality data products safely, at the lowest possible operating cost, the OOI program continuously monitors the operational performance of deployed systems, as well as business processes to establish, and communicate performance. The program identifies, and prioritizes problem areas, conducts analyses, and applies lessons learned to improve performance and reduce costs. These processes include quarterly data-driven reviews, trade studies, supportability analyses, and the analysis and implementation of alternative strategies.

3.6.5 Continual Improvement Process/Technical Refresh

Management for technical refresh at periodic intervals is a life-cycle support strategy for OOI. This strategy is a consideration for spares and repair parts as well as obsolescence planning. The Instrument technical refreshment plan is defined in 1100-00007 OOI Instrument Tech Refresh.

Planned Upgrades/Technical Refresh: As technology advances are made, some of them are incorporated into the IO equipment. These are spread out over years and do not necessitate out-of-cycle maintenance. They are proposed and approved through the Configuration Management Process.

3.7 Cyberinfrastructure

The PMO Senior Manager of Cyberinfrastructure (SMC) is responsible for implementing the Cyberinfrastructure (CI) technological solution for the OOI cabled and un-cabled arrays to accomplish the OOI's goals and missions. The SMC overall OOI CI operational and managerial leadership, including setting priorities, managing teams, and developing and reporting on OOI CI performance metrics. Managed CI processes include the following:

3.7.1 CI Management Execution

CI provides maintenance contracts for the COTS software being used to monitor system resources and tracking the health and well-being of the storage, computational, and network resources. Advanced notifications are provided to the OOI user community when changes to the software applications are to be applied. Typically, these are performed in the first week of the month when needed. CI system maintenance is performed quarterly if needed also with advanced notice to the user community. CI may be required to apply emergency maintenance without prior notice to get a critical system operational or fix a security exposure that may harm the CI infrastructure. Notifications are sent out prior and after the systems are again operational notifying users of the outage and resulting fix.

3.7.2 Software Release Process

CI is releasing fixes and updates to the OOI base software at periodic intervals that include updates with new features and fixes to reported problems. CI applies application and patches during regularly scheduled down times to operating system software, COTS application software and databases.

CI may be required to apply an emergency fix without prior notice to get a critical system operational or fix a security exposure that may harm the CI infrastructure. Notifications are sent out after the systems are again operational notifying users of the outage and resulting fix. Details of the software release process are captured in the Configuration Management Plan, DCN 1000-00000.

3.7.3 Cybersecurity

The OOI is an, research-oriented system of systems and is not classified as a federal information system under the purview of the Federal Information Security Management Act (FISMA). However, information assurance related risks and threats exist and the OOI takes all reasonable measures to ensure the system remains operational, there is no interruption in data access (data availability), and the data are accurate within established quality assurance/quality control parameters (data integrity).

The OOI program uses the Trusted CI recommendation that CI implement the CIS controls, see <https://www.cisecurity.org/controls/>. The plan is to start implementing these CIS controls in PYIV

as the basis for the OOI Cybersecurity requirements, and has tailored the detailed requirements as needed provided in CyberSecurity Plan, DCN 1012-00000.

3.7.4 System / Equipment Monitoring

The CI ensures continuous availability of OOI data products produced from MIO-supplied instrument data and accurate system status to the scientific customer base. CI and the MIOs are responsible for monitoring system status and responding and alerting PMO O&M and relevant IO O&M personnel to any degradation of availability. CI tracks changes in CI-related system status and notifies all stakeholders of changes and mitigating actions that are in progress.

The CI monitors data flow and status data from the marine assets and provides a regularly updated status display of the OOI CI Systems infrastructure. CI monitors the availability of system resources, network performance, and growth of storage. Automated alerts notify the CI Operations staff when critical threshold limits are reached so that proactive actions can be taken before a potential problem occurs. CI conducts annual or more frequent reviews to determine if the Service Level Agreements (SLA) are being met, and make any necessary adjustments in support of the user community.

The RCA Primary Infrastructure has a Network Management System (NMS) for monitoring and surveillance of the network. The capabilities of the discrete alarm points of the NMS are exploited to enhance the ability to monitor other areas of the infrastructure such as the Secondary Infrastructure, as well as environmental or building alarms associated with the shore station. These enhancements to the Primary Infrastructure NMS form the basis of the Observatory Management System (OMS). The OMS is configured for automated alerts to all on-call personnel for critical and major alarms.

The OMS is protected by high-security validation features, which enable secure remote access to appropriately trained RCA personnel. Active surveillance of the Infrastructure occurs during the normal business day from a virtual RCA operations center. After-hours support is provided through a tiered on-call support list, with predetermined escalation lists.

A CGSN Operations and Management function monitors the system and the equipment and generates internal trouble reports as required (see section 3.6.2 OOI Performance Metrics).

3.7.5 HelpDesk Support

The science community, educational institutions, and the general public have access to the OOI data and products through the OOI website, at oceanobservatories.org/helpdesk. The OOI HelpDesk's mission is to provide the user community an effective, primary point of contact for timely and consistent response of computing and information technology-related inquiries. The HelpDesk creates a single point of contact to request services and report problems and provides status feedback to users of OOI resources and applications. The HelpDesk is the central point of contact between users and the resources provided by OOI.

Typical services provided by the HelpDesk include:

- Reporting problems
- Requests for account support
- Follow-up with users for resolution of problems or requests

The HelpDesk offers the first line of support to the OOI user community. If further assistance is needed, the HelpDesk may direct the query to the systems support staff, the development team, or the Marine IOs.

The CI manages log-ins, passwords, user classes, and permissions for interactivity. In addition, the CI sends notices to users for planned events and regular updates on unplanned outages.

3.7.5.1 CI Fault Detection & Reporting

When an alarm/alert situation occurs, stakeholders are notified through channels such as OOI's website (www.oceanobservatories.org), Discourse, and Redmine tickets, depending on the nature of the incident.

3.7.5.2 Data Security

As the developer of the OOI data communication and storage infrastructure as well as the data manipulation software, the CI has a lead role in data security. With respect to system data security, CI and the other IOs abide by all Security requirements specified in the CyberSecurity Plan, DCN 1012-00000. In cooperation with CI, the MIOs execute processes and safeguards to ensure the integrity of all data from origination at the instrument level to the interface point with the CI.

In addition to the scientific data, the infrastructure health and status data are collected. Health and status data are critical for both near real-time and historical purposes for the correction of problems and system faults, but can also be predictive and indicate a need for preventive processes.

As critical vulnerabilities are identified and software fixes become available, the associated patches are applied in a systematic fashion. To provide a scalable mechanism to perform upgrades, the CI uses a combination of software deployment servers that are designed to automatically install patches to operating systems, COTS applications and database software over a secure network. Each patch/fix is first tested in the development, and UAT environments before being deployed to production.

Acquisition and public distribution of acoustic and other data collected in some regions along U.S. coastlines may pose a national security risk. As a result, the PMO and NSF have coordinated a set of rules to restrict operations and/or data access, or restrict publication of results. The RCA, CGSN, and CI IOs implement the conditions levied as a result of these discussions. No other restrictions on data availability or operations are formalized in this plan.

During system upgrades or maintenance, it may be necessary to halt the flow of data from the affected part of the system for a brief period. The CI, in coordination with the relevant IO, has procedures to notify users of a scheduled outage, and ensure that such scheduled outages produce minimal impact to the operation of the OOI as a whole. They also perform tests to verify that the restored data flow conforms to expected quality standards. Similarly, upgrades of the observatory software are coordinated through the CI and are tested with the relevant IO to ensure backward compatibility.

The OOI Data Use Policy, DCN 1102-00010, requires data providers to provide information regarding the provenance, description, quality, maturity level, calibration, and collection context of their data. This metadata helps users understand the quality level of the data.

Finally, any new sensors are first approved for use on the OOI according to a formal review process that addresses security, Configuration Management, and other relevant issues. The MIO, as part of operational security, confirms that any sensors planned have been approved as part of the configuration baseline.

Operational Security includes the measures taken to ensure a high level of availability of OOI data, while maintaining data integrity. Therefore, the everyday science operations, as well as operations and maintenance of OOI, are carefully planned and executed to ensure that unexpected consequences do not occur, and that a recovery plan is in place to be implemented immediately if they do.

The continuous monitoring of system health and of data quality and data utilization is performed, to ensure immediate notification of any system or product degradation. Trending analysis of system performance is also performed, to help identify or predict more gradual system performance problems. A detailed list of configured operational items allows complete tracing of all hardware and software assets involved in any security related events.

The OOI Data Use Policy, DCN 1102-00010, describes that all basic OOI data streams are open and freely available to any potential user.

The CI has responsibility to ensure that the OOI data and programs are not susceptible to cyber-attacks in the form of viruses, malware, denial of service attacks, etc. and to ensure that the data cannot be corrupted by outside influences. A formal tracking system that documents the cause and resolution of each logged attack or intrusion is implemented. The system will utilize two virtual and physical network and service environments: one for the CI data interactions (Public Wireless Local Area Network (WLAN)) with the users via the public Internet/Internet2 and the other for the CI interactions with instruments (Service and Marine Virtual Local Area Network (VLAN)) via the OOI network infrastructure as exemplified by the conceptual system view within the Final Network Diagram. Similarly, Virtual Local Area Networks are utilized to separate out varied functionalities within the physical infrastructure.

The CI is also responsible for implementing data and system back-up architecture for service interruptions or disasters. There is a full off-site backup for all OOI-related data and software.

3.8 Community Engagement Management

The OOI Principal Investigator (PI), Community Engagement Manager (CEM), and IO teams implement Community Engagement activities throughout each Program Year. This collective effort is designed to culminate in a robust, engaged, growing OOI community. The OOI PI and CEM coordinate the program-wide effort and, together with the IO Principal Investigator / Project Scientists (PI/PS's), serve as the public face of the OOI. The IO PI/PS's are responsible for the execution of Community Engagement activities at their individual IOs. The OOI Facilities Board (OOIFB) and its Data Systems Committee (DSC) also advise, support, and contribute to OOI Community Engagement activities.

The 1060-00000 Community Engagement Plan provides a roadmap for Community Engagement during OOI 2.0, commencing 1 October 2018 and ending 30 September 2023. The Plan informs the development of the scope, and the timeline of specific Community Engagement activities that are defined in the Annual Work Plan (AWP) for each Program Year.

3.9 OOI Opportunities for the Science Community

The OOI Program provides opportunities for the Science Community to engage and interact with the Program. These interactions include the integration of new science instruments, the ability to modify the sampling rates of one or more deployed instruments, the opportunity to deploy 3rd party equipment in OOI-permitted areas, loaning of OOI equipment, and the selection and implementation of a new site for the Pioneer Array. The process for each of these opportunities is provided in the subsections below.

3.10 Process for Adding Instruments

1. The External Investigator (EI) submits an inquiry to the Principal Investigator / Project Scientist (PI/PS) at the impacted Marine Implementing Organization (MIO) through the OOI Helpdesk (<https://oceanobservatories.org/helpdesk/>), through ooicable@uw.edu (for the Cabled Array), or through another channel.
2. With the help of the MIO, the EI completes and submits an Instrument Integration and Planning Form.

3. The MIO PI/PS brings the proposal to the Science Oversight Committee (SOC) for confidential review. At the SOC meeting:
 - a. Requests for approval of one-year data embargos for non-Commercial Off the Shelf (COTS) instruments are discussed with the National Science Foundation (NSF) representatives. Data Embargos occur when access to data for one or more specific instruments is restricted to a given EI or organization.
 - b. Risks of gaining Engineering Change Request (ECR) approval if/when the EI proposal is funded are evaluated.
 - c. Requirements for permission from the US Navy are reviewed. Navy permission is required for addition of all instruments to the Cabled Array and operations at the Pioneer Array. Navy permission might be required for instruments on other Arrays, particularly those involving acoustics. If Navy concerns exist, the MIO and EI, working through the NSF, must request Navy permission prior to submission of the EI proposal.
 - d. The time required to complete steps 4 and 5 (below) is evaluated.
 - e. The SOC approves or disapproves the request. The MIO PI/PS reports the outcome to the EI. If the request is approved, the following steps occur.
4. The MIO PI/PS and/or Project Manager (PM) create a Technical Cost & Feasibility Letter for inclusion in the EI proposal. The TCFL must state that there was SOC review. In addition to describing the cost and scope of the project and providing an overall feasibility assessment, the TCFL includes the following as needed:
 - a. Mechanical, electrical and software engineering.
 - b. Fabrication and testing.
 - c. Data storage, processing, QA/QC, accessibility, delivery, and management.
 - d. Data telemetry costs and shipboard satellite costs.
 - e. Environmental compliance.
 - f. Possible interference with other OOI instrumentation.
 - g. Operations and scheduling considerations, including ship and ROV costs, EI berthing needs, deck and lab space, and support for OOI staff participation on cruises. Logistics and costs for deployment, operations, and recovery are addressed.
 - h. Setting up PI instrument pages, servers and FTP sites.
 - i. Other issues as necessary.
5. The EI submits a proposal to obtain funding for all activities and expenses related to the additional infrastructure that are beyond the OOI scope as stated in the OOI Annual Work Plan (AWP). Work by OOI is documented as NSF Collaborative Research, a subcontract, or similar vehicle. The EI proposal includes the TCFL (as supplemental material), and, if the proposed instrument addition is feasible, a statement of work (SOW) and budget from the MIO, in addition to other material that may be required by the agency or institution. If a one-year data embargo has been approved by NSF (step 3), this should be part of the Data Management Plan in the EI proposal. For proposals requiring seagoing support, the expectations for ship time, berthing, and deck and lab space are included in the SOW. OOI objectives have priority over EI objectives during cruises.
6. The EI is expected to inform the MIO PI/PS regarding the proposal outcome. If no communication occurs, the MIO PI/PS prompts the EI and checks the UNOLS ship schedules if necessary to determine if the EI proposal has been scheduled.
7. If the EI obtains funding for the deployment, operations, and recovery:
 - a. The MIO PI/PS notifies the SOC.
 - b. If required by the OOI Configuration Management Plan (CMP), the MIO submits and receives approval for an Engineering Change Request.
 - c. The EI and MIO finalize schedules and plan operations.
 - d. The EI is responsible (with MIO assistance if necessary) for meeting the OOI Environmental Compliance (EC) Procedure and filling out the Organization

Environmental Impacts Checklist. The MIO submits the documents to the PMO, which reviews and forwards them to NSF. The MIO, PMO and NSF work with the EI to ensure that the new infrastructure/instrument does not violate OOI environmental compliance requirements.

3.11 Process for Modifying Instrument Sampling

1. The External Investigator (EI) submits a request to the Principal Investigator / Project Scientist (PI/PS) at the relevant Marine Implementing Organization (MIO) through the OOI Helpdesk (<https://oceanobservatories.org/helpdesk/>), through ooicable@uw.edu (for the Cabled Array), or through another channel.
2. The MIO PI/PS performs an evaluation of the proposed new sampling strategy, comparing it against the existing baseline as documented in Document 1102-00200, OOI Observation & Sampling Approach, and assesses the scientific benefits of the proposed new sampling strategy, and the operational and scientific risks of adopting the new sampling strategy.
3. The MIO PI/PS brings the request to the Science Oversight Committee (SOC) for confidential review and approval or disapproval. If an Engineering Change Request (ECR) is anticipated, risks of ECR approval are reviewed; if a risk is identified, the MIO develops a mitigation strategy. The MIO PI/PS informs the EI of the outcome of the review.
4. The MIO PI/PS and/or Project Manager (PM) create a Technical Cost & Feasibility Letter for inclusion in the EI proposal, if applicable. The TCFL includes the cost and feasibility of the following as needed:
 - a. Mechanical, electrical and software engineering.
 - b. Testing.
 - c. Data storage, processing, QA/QC, accessibility, delivery and management.
 - d. Data telemetry costs and shipboard satellite costs.
 - e. Environmental compliance.
 - f. Possible interference with other OOI instrumentation.
 - g. Operations and scheduling considerations.
 - h. Other issues as necessary.
5. If the EI requires funding to implement the sampling change, the EI submits a proposal to obtain funding for all activities and expenses related to the sampling change that are described in the TCFL and beyond the OOI scope as stated in the OOI Annual Work Plan (AWP). Work by OOI is documented as NSF Collaborative Research, a subcontract, or similar vehicle. The EI proposal includes the TCFL as supplemental material, and, if the proposed sampling change is feasible, a statement of work and budget from the MIO, in addition to other material that may be required by the agency or institution.
6. The EI is expected to inform the MIO PI/PS regarding the proposal outcome. If no communication occurs, the MIO PI/PS prompts the EI and checks the UNOLS ship schedules if necessary to determine if the EI proposal has been scheduled.
7. If the proposed sampling plan is to be implemented:
 - a. The MIO PI/PS notifies the SOC.
 - b. The MIO submits an ECR if required by the Configuration Management Plan.
 - c. The EI and MIO finalize schedules and plan implementation of changes.
 - d. The Program documentation is modified as required to reflect the sampling change.
 - e. The sampling change is implemented.
 - f. The MIO PI/PS monitors and evaluates the revised data streams.

3.12 Process Reviewing Deployments in OOI-permitted Areas

1. The External Investigator (EI) communicates with the Principal Investigator / Project Scientist (PI/PS) at the relevant Marine Implementing Organization (MIO) through the OOI Helpdesk (<https://oceanobservatories.org/helpdesk/>), through ooicable@uw.edu, or through another channel.

2. The MIO PI/PS brings the information to the OOI Science Oversight Committee (SOC) for review.
3. If there are potential conflicts or synergies, the MIO PI/PS contacts the EI, and the MIO and/or the Program Management Office (PMO) may assist the EI by providing information about environmental conditions, permitting considerations, and operations, locations, and sensitivities of OOI infrastructure.
4. The MIO PI/PS informs the EI in writing that the EI is responsible for meeting environmental compliance and permitting requirements, and that the OOI does not have the authority to approve or deny any plans to deploy instrumentation near OOI assets.
5. For projects where there is risk regarding possible impacts to OOI infrastructure, the MIO works with the EI and provides a document that outlines the risk and resolution (or lack of resolution), with a written record by the MIO and EI. The document is sent to the PMO and NSF.
6. If necessary, the OOI and the NSF provide comments on permit applications submitted by the EI.

3.13 Process for Loaning OOI Equipment

1. The External Investigator (EI) submits an inquiry to the Principal Investigator / Project Scientist (PI/PS) at the relevant Marine Implementing Organization (MIO) through the OOI Helpdesk (<https://oceanobservatories.org/helpdesk/>), through ooicable@uw.edu (for the Cabled Array), or through another channel.
2. The MIO PI/PS presents the request to the OOI Science Oversight Committee (SOC) for review.
3. If the outcome of the SOC review is positive, the MIO submits a written request to the Program Management Office (PMO) that includes the following:
 - a. A summary of the benefit to OOI.
 - b. An assertion that the MIO will follow the OOI property custody, movement, and tracking processes as defined in the Property Management Plan.
 - c. Identification of the borrower and documentation of the equipment location when borrowed, the reason for the loan, the anticipated date when the equipment will be returned, and the persons responsible at the borrower's institution and the MIO for the equipment while on loan.
 - d. The estimated replacement cost of the material.
 - e. Assertions that the Program does not need the equipment during the loan period and there is no risk to the Program associated with the equipment being unavailable for the loan period. If these assertions are not true, then the equipment cannot be loaned.
 - f. Assurance that the written loan terms provide that the equipment will be returned in the as-borrowed condition, with all repair, refurbishment, calibration or replacement costs borne by the borrower.
4. The PMO forwards the request to NSF for approval. If NSF approves, the PMO informs the MIO, and the loan proceeds.
5. The MIO logs the documentation and outcome.

3.14 Pioneer Array Relocation

The Pioneer Array was designed to be relocatable to a new geographic area on an interval of once per five to ten years. The NSF initiated a process to consider the first possible relocation of the Pioneer Array in late 2020 with a series of meetings to solicit community input. In May 2021, a decision to relocate the Pioneer Array to the Mid-Atlantic Bight region in 2024 was made based on science questions, educational opportunities, and potential partnership collaborations offered at this new location.

Members of the PMO and CGSN team participated in these community meetings, providing technical considerations and operational constraints involved in moving the array. The PMO and CGSN will continue to work collaboratively with NSF to ensure this and subsequent potential moves proceed smoothly and ensure that technical, permitting, and budget considerations are addressed.

Some of the issues that need to be addressed include:

- decommissioning of the current site and timing and logistical considerations of installation of the array at a new location;
- budgetary considerations to keep the Pioneer array site move and refinement costs within the PMO's annual operating budget;
- determinations regarding permitting requirements including whether a review of a new location will be required by the National Environmental Policy Act (NEPA);
- identification and implementation of site-specific modifications to the array's infrastructure to accommodate conditions in a new location; and
- logistical, scheduling, and support requirements at a new location.

The next Pioneer Array move is not expected for at least five years after the 2024 deployment at the new location.

3.15 Unplanned Event Management

From time to time, unplanned events may occur that impact the infrastructure, such as intentional or unintentional acts of aggression against one or more program elements, or local-, regional-, or global-scale disasters. To address these events, Institutional Disaster Recovery Plans and Emergency Response Plans provide planned responses to extraordinary emergencies related to disasters, both man-made and natural. The Emergency Response Plans focus on large-scale disasters that can generate unique situations demanding unusual, non-routine responses. Where these Plans do not directly address disasters that impact the program, such as the 2020 COVID pandemic, the IOs work with their respective institutions and the PMO on developing mitigation plans.

3.16 Environmental, Health & Safety

Particular emphasis is placed on safety, proactively implementing safety policies and procedures and the immediate reporting of any safety related issue or event to program staff at the PMO (1006-00002 OOI Environmental Health and Safety Plan).

For CGSN and EA, the UNOLS Research Vessel Safety Standards (RVSS) are followed at-sea, and the Institution safety guidelines are adhered to ashore. The CGSN Environmental Health and Safety Plan and procedures are followed during all O&M activities. Furthermore, UNOLS and institutional (WHOI and OSU) policies and procedures are followed during recovery and replacement of equipment using ships. (CSGN Environmental Health and Safety Plan, DCN 3101-00009). EA follows Oregon State University's Health and Safety procedures, and has specific procedures for OOI unique procedures.

For RCA, the UNOLS RVSS and UW policies and procedures are followed during marine operations; and UW safety guidelines are adhered to ashore. The RCA Environmental Health and Safety Plan, DCN 4011-00001, is followed during all O&M activities.

3.17 Annual Work Plan (AWP) Process

The OOI 2.0 Operations & Management Budget is currently \$44M per year, with the NSF as the sole funding agency. The annual budget is comprised of five major components organized via a Work Breakdown Structure (WBS). The AWP defines all of the Level of Effort (LOE) labor and non-labor (fixed and other costs) scope and budget for operations and management of the observatory, and includes the following components:

- Management
- Refurbishment
- Deployment and Recovery
- Community Engagement
- Cyberinfrastructure

3.18 Assumptions Supporting Schedule and Budget

The OOI O&M schedule and budget are based on the following elements:

1. The OOI was validated to the Concept of Operations (CONOPS) at the end of commissioning. The CONOPS, DCN 1013-00000, together with approved updates to the baseline, define the basic deliverables and functions for the OOI facility. High-level assumptions include the following:
 - a. Coastal Arrays are turned twice per year (Spring and Fall).
 - b. Coastal Gliders and the Coastal Surface-Piercing Profilers are turned nominally four times per year.
 - c. AUV's are operated at the Coastal Pioneer Array in expeditionary mode during Pioneer turn cruises, as well as during periodic small boat operations.
 - d. The two Global Arrays and the Regional Cabled Array are turned annually.
 - e. Proposals to use OOI data for research and related science activity purposes are funded with separate funding, outside of this Award, as are external additions to OOI instrumentation or infrastructure.
2. The OOI Technical Data Package (TDP), system permits, and system leases are documented in the Validation Report, DCN 1145-00001, and Commissioning Report, DCN 1141-00001, dated November 6, 2015, and November 30, 2015, respectively. The marine infrastructure TDPs provide detailed engineering requirements and designs, verified and validated to the CONOPS.
3. Program Schedule Estimate assumption: The refurbishment and deployment cost estimates are based on historical data and anticipated ship schedules and associated costs.
4. Program Cost Estimate assumptions:
 - a. Cost estimating methodology is detailed in each IO's Cost Estimating Plan (CEP) and supports the Cost Books.
 - b. All costs are fully burdened and include applicable indirect costs based on current rates.
 - c. Level of Effort (LOE) labor and full-time equivalent (FTE) allocations are sufficient to provide the OOI scope and function as described in the CONOPS.
 - d. Integration and Test Estimates are based on historical actuals activity-based, with defined build, integration, and test costs for systems and subsystems.
 - e. Instrument refurbishment estimates are based on vendor quotes and actuals from prior years.
 - f. Glider, AUV, Wire Following Profiler, and Coastal Surface Piercing Profiler (CSPP) estimates are based on vendor quotes and actuals from prior years.
 - g. Travel details are representative of the types of trips planned based on program activity. Actual travel may vary. Travel costs are budgeted with the assumption that in-person conferences, meetings, and visits can be conducted effectively in PYIV. If unforeseen events such as pandemics protocols result in canceled or virtualized events, travel budgets are reassessed.

- h. Costs for telemetry using Defense Information Systems Agency (DISA) service on Iridium cards are paid by NSF directly, with OOI funding held by NSF for this purpose.

3.19 Approach to Cost Escalation

To address the risk of cost escalation due to inflation and other factors, the Program incorporates the following mitigations into the AWP:

1. Meet surge labor requirements from within the IOs, rather than through the use of more expensive external contractors.
2. Based on past Program performance, reduce the number of mobilization, cruise, and demobilization days, where possible.
3. Strategically utilize attrition to replace refurbishment engineer staff with less expensive technicians.
4. Pursue opportunities for ancillary cruise objectives that are paid for outside of OOI.
5. Increase efficiencies from documenting and streamlining recurring tasks reducing labor costs.
6. Increase refurbishments versus replacements where they meet performance requirements and provide cost savings.
7. Conduct more refurbishments of some assemblies using less expensive in-house labor versus outsourcing.
8. Update designs to reduce material and refurbishment costs.

3.20 Science Oversight Committee (SOC)

The Science Oversight Committee (SOC) draws upon the long-term engagement of its members, coupled with recognition of the science drivers for and design of the OOI, to provide program oversight on matters impacting science requirements, data delivery and science user engagement. Further it serves the important role of promoting outreach to the community from within the program, in part by supporting workshops and user engagement activities (e.g. informational webinars). Membership of the SOC will include the OOI lead PI and PI/PS's from the four Implementing Organizations (IOs), providing knowledge of the science requirements for Global, Cabled, Endurance, and Pioneer Arrays, and the OOI Cyberinfrastructure. The NSF/OCE Program Officers responsible for the OOI and the Chair and Administrator of the Ocean Observatories Initiative Facility Board (OOIFB) are ex officio members. Other subject matter experts may be invited to participate as deemed appropriate by the SOC members. The SOC chair is the OOI PI. The SOC is charged with the following:

- Providing guidance and perspective on the performance of the OOI Marine and Cyber infrastructure with respect to addressing the scientific and operational aspects of the program.
- Reaching out to inform and engage the science community in discussions about the OOI, its successes, shortcomings, and options for improvement. These activities include representing the OOI at selected science, engineering, and education meetings, organizing special sessions at meetings, organizing workshops, and advocating use of the OOI, including process studies and fieldwork at and near OOI sites.

4 Marine Implementing Organization Management and Operations

The OOI PMO is responsible for overall OOI Operations and Management. Day-to-day maintenance of the deployed OOI components is provided by the MIOs, who are responsible for their cost and schedule, as well as the maintenance of the elements they designed, constructed, and deployed.

4.1 MIO O&M Management

MIO management functions are accomplished by the MIO operations teams using the enabling technologies and computing infrastructure provided at the various observatory management facilities. In general, the observatory management hardware and software support the man-machine interface and capability to retrieve, process, and archive data from marine operations, remotely control platforms including AUVs and gliders, and distribute information to the cyber-infrastructure.

The MIO management functions include the preparation and deployment of OOI assets, the at-sea operation, and subsequent recovery, and includes the collection of data captured by the mooring and vehicle instruments during their deployment. Remote control interfaces provide the ability to alter mission profiles, obtain operational status, diagnose problem causes, and implement corrective actions to maintain optimal mission performance.

4.2 MIO Common Operations

There is a set of MIO operations that are common to all three MIOs. The MIO Common Operations mission is to deliver common operational processes and procedures that support the operation of the OOI Observatory across multiple institutions as a single system. It includes the following focus areas:

- Operational Financial Processes: Financial operational management and reporting procedures, including O&M vendor management (support contracts), life cycle procurement processes, and asset and property tracking.
- User (Customer) Support: Integrated user management support for OOI users (customers) including OOI system event resolution, technical support requests, reporting metrics, and new service requests (e.g., consultation for adding new PI sensors).
- Operational System Management: Integrated system operations procedures and policies for the OOI system including System health management and performance reporting, and Operational control of OOI assets, including Glider mission planning and adaptive sampling at instrument/sensor level.
- Programmatic Annual Processes: Annual programmatic process and timeline that effectively coordinates cross IO activities supporting OOI work planning including the Integrated O&M Plan, annual O&M schedule, and coming project year AWP.
- Procurement Processes – including life cycle procurement
- Inventory Management – including maintenance history
- Vendor Management – Maintenance contracts – Hardware/software licenses
- Vendor contract support based on warranties, service agreements
- User support procedures (internal and external OOI users)
- Trouble ticket management procedures
- Technical support procedures
- User satisfaction reporting procedures
- Performance metrics and service level agreements support
- Mission planning
- Monitor system health
- Planned maintenance based on service history and alerts
- Training programs – including safety
- Performance metrics and service level agreement support
- System design modifications (including technology refreshes) support
- Programmatic document updates and inputs
- Schedule & Budget
- Annual Work Plans
- NSF Review

4.3 MIO Operations

Maintenance is based on a deploy, recover, replace, and refurbish model. Equipment is deployed for a specific deployment interval then recovered and refurbished or replaced with

equivalent equipment. The recovered equipment returns to the MIO depot to be refurbished to support future “recover and replacement” operations. Because maintenance is a cyclical process, corrective actions are folded in as equipment is recovered and refurbished. Maintenance depots are established at WHOI, OSU, and UW for their specific equipment. While infrastructure is operational, MIO’s collect data related to the health and operational status of the assets and the connecting infrastructure.

Equipment assemblies and sub-assemblies procured from third-party suppliers are returned to the supplier to the greatest degree possible for refurbishment. This includes instrument calibrations.

All MIOs maintain appropriate levels of non-Commercial off the Shelf (COTS) components, assemblies, and platforms. Personnel trained and familiar with the equipment participate in refurbishment, deployment, and recovery of equipment.

MIO Operations include supporting array lifecycle activities including the following:

4.3.1 Refurbishment

Refurbishment combines original manufacturing practices and specific maintenance procedures to return equipment to its factory acceptance level. Instruments and equipment subsystems, systems, and configuration items are cleaned, inspected, disassembled for repair or replacement, and disposed of if required. Parts are re-tested per their original processes to meet the original equipment requirements when necessary. Some structural parts are systematically replaced due to structural duty cycle limits. Records of refurbishment are analogous to Construction records – test results, as-built configuration, pre-installation test, and Burn-in test. Following Burn-in, an Installation Readiness Review (IRR) is performed to move the equipment to the Field Operations domain.

For the MIOs, recovered equipment is returned to shore-side facilities for maintenance. However, large and bulky material, that does not require specialized attention and can be stored away from the operations management monitoring locations until used again, is maintained where possible at sites closer to the cruise ports to save shipping costs and potential delays.

After recovery, at sea, or in a remote port, all equipment exposed to seawater is washed down. The wash down is conducted per applicable IO procedures to prevent the migration of invasive species or other harmful substances into the environment.

At the shore-side facility, equipment assemblages are disassembled into components. Components are cleaned, inspected and inventoried. Any discrepancies in quantity, any failed instruments or mooring elements, or other problems are noted and the appropriate trouble tickets are generated. Any data not previously downloaded is downloaded to the appropriate database and all metadata are logged as per OOI operational procedures.

After refurbishment and testing, the item is returned to storage until it can be assembled into the appropriate subsystem or system element. Any item deemed non-repairable or not economical to repair is retired per OOI Property Management Plan, DCN 1011-00000.

The OOI Refurbishment and Calibration mission is to determine cross-project functions for Refurbishment and Calibration of infrastructure and instruments on OOI, and includes all processes that occur from when instruments and/or infrastructure are recovered until the next deployment including the following focus areas:

- Equipment Refurbishment: All processes and procedures required to support equipment refurbishment between Field Operations drop off and pick up of equipment.

- Instrument Refurbishment and Calibration: All processes and procedures required to support instrument refurbishment and calibration, including packing, shipping, vendor communications, receiving, reassembly, and quality assurance.
- Inspection, Test, and Logistics: All processes and procedures required to support inspection, testing, and the associated logistical tracking of execution and results before redeployment.
- Technology refresh implementations
- Metadata of serviced components (including instrument calibration values) are checked and entered into CI's Asset Management system

4.3.1.1 Preventive/Predictive Maintenance

Preventive maintenance for OOI relies on OEM recommended maintenance, IO experience with similar equipment, and IO knowledge of new designs. Maintenance periodicity is governed by the refurbishment turns as planned for the marine infrastructure.

Maintenance applies to hardware as well as software. Software maintenance is generally supported by OEM software maintenance contracts for bug fixes and patches. System monitoring and reporting of degraded or failed components provide trend data associated with system assets. As trends are discovered, maintenance plans may be adjusted to resolve issues.

4.3.1.2 Diagnostics / Troubleshooting

The CI has primary responsibility for CI infrastructure troubleshooting. The RCA, through the OMS, and CGSN and EA, through engineering diagnostics, have monitoring and infrastructure troubleshooting capability. Trouble tickets for both instruments and infrastructure are maintained in the OOI Redmine application. The MIOs provide updates and schedule meetings with the PMO to review issues related to infrastructure operations and corrective or mitigating activities that are being performed by the IOs.

Emergency failures require immediate decisions on how to proceed, possibly including scheduling a UNOLS vessel or the chartering of a commercial vessel to intervene. Re-budgeting to find funding is attempted to respond to these types of failures. Examples are:

- Mooring adrift failure - the breaking free and drifting of a mooring or mooring component
- Communications failure - loss of all communications with a mooring

Critical failures compromise scientific data collection by an entire subsystem or could lead to an emergency failure. These failures require a timely decision on how to proceed, dependent on cost, science impact, weather, and scheduling of available resources. These failures may be deferred until the next scheduled maintenance trip. Funding to respond to critical failures requires re-budgeting. Examples are:

- Loss of an entire instrument system (e.g., ASIMET out)
- Loss of navigational aid (e.g., buoy lights or radar transponder)
- Glider loss or failure (glider on surface signaling recovery request)

Subcritical failures compromise scientific data of a single instrument. These failures require a response decision, possibly during a ship of opportunity visit, but more likely would be deferred until regularly scheduled maintenance. Examples are:

- Evident biofouling of a single instrument
- Failure of a non-core instrument

In all types of failures, shore-side efforts are directed at minimizing data loss using remote tools to the degree possible. Examples are powering down specific Data Concentrator Logger (DCL) ports, modifying sampling plan, modifying telemetry plan, etc. OOI failures that impact data delivery are reported to the science community through the OOI website.

4.3.1.3 Repair and Replacement

Repair management of recovered infrastructure ensures the timeliness, type of repair (e.g., inspect/repair as necessary, disposal or overhaul). Equipment is repaired on an as-needed basis during the refurbishment process. Items requiring replacement vs. repair are documented and reviewed for any necessary corrective action.

4.3.1.4 Failure Analysis, Reporting, and Corrective Action

Failure analyses, reporting, and corrective actions are used to provide a vital feedback loop to monitor failure trends and to implement corrective actions above and beyond repairs with recurring reliability improvements. These processes are implemented through the Redmine issue resolution, and the Quarterly Data Driven Review processes. The status of the failure analysis is tracked in the Redmine issue tracking system. The failure analysis is led by the PMO Program Engineer, and may be the subject of a Quarterly Data Driven Review. Corrective actions are determined and when design changes are necessary, the Configuration Management Plan is followed

4.3.2 Installation Readiness

Pre-deployment activities are centered on cruise planning, platform integration and testing, and burn-in to ensure that all infrastructure is ready to deploy and that at-sea tasks have all the resources necessary to accomplish the goals of the cruise.

Meta Data – OOI operations ensure that all data relating to the configuration of the subject assets are accurately recorded before and during the integration and test of the deployed infrastructure. This includes recording serialized hardware asset management data, software configuration, instrument calibration data, and sampling strategies.

Platform Configurations – Platform configurations are tracked and made available to OOI users.

Support Platform Test and Integration – Following refurbishment of platform components, MIO personnel participate in the integration and testing and burn-in of each platform before shipping for deployment. MIOs record metadata into CI's Asset Management system before deployment and then update metadata post-deployment.

In addition to refurbishing deployable platforms, MIOs also refurbish all equipment used to refurbish and deploy deployable platforms.

Once Burn-In of all platforms is complete, an Installation Readiness Review occurs. Upon successful IRR completion, components are packed and shipped to port.

4.3.3 O&M Field Operations

The Field Operations mission is to ensure that all aspects of OOI field operations are well-planned, scheduled, documented, and cost-justified through the transition from construction to full operations and management. It includes the following focus areas:

- Cruise Planning: Define the plans, procedures, and practices for the support of at-sea operations, costing, and schedules.
- Field Facilities: Maintain field facilities and equipment, including all buildings and areas required for storing, staging, mobilization, and demobilization, refurbishment, testing, and field calibration of infrastructure to be deployed on the OOI Marine network.
- Field Operations: Ensure the successful, safe, and efficient deployment and maintenance of OOI infrastructure and collection of associated environmental data.
- Pre-cruise documentation (e.g. cruise plan)
- Operation reporting/documentation (e.g. cruise reports)

- Post-cruise data products to R2R and OOI data repositories
- Collaboration on staging and storage facilities (e.g. Sand Pt.)
- Lease and rental agreements (e.g. Oregon staging)
- Space requirements and storage plans
- Logistics documentation
- Daily science and operations reports during cruises
- Asset tracking documentation
- Physical sampling protocols and protocols for physical sample data delivery to CI
- Metadata documentation
- Staffing and chain of command
- Safety

4.3.4 Scheduled Field Operations

The Coastal Arrays include the Endurance Array operated and maintained by OSU, and the Pioneer Array operated and maintained by WHOI. The Endurance moorings not connected to the cable are serviced each spring and fall, with a University-National Oceanographic Laboratory System (UNOLS) vessel used to deploy new moorings and recover the previously deployed moorings. The science infrastructure connected to the RCA cable is serviced by RCA operations once per year. The Endurance Array's six gliders and 4 CSPPs are serviced every 2-3 months from chartered small vessels. Endurance Array data flows to the CI through the RCA cable, via satellite and GSM Modem and via manual connection to the internet for delayed-mode data recovered from instruments after recovery.

Spring and fall cruises on UNOLS vessels service the Pioneer Array moorings, deploying new hardware and recovering previously deployed hardware. Several times per year additional cruises on smaller, non-UNOLS vessels recover and redeploy gliders, CSPPs, and AUVs. Data flows from the Pioneer Array to CI in near real-time via satellite telemetry. Delayed mode data is provided manually via the internet when instruments are recovered.

The global arrays are serviced on UNOLS vessels once per year in northern summer, at the optimum time of year when the combination of wind, waves, and occurrence of gales are most favorable.

The surface mooring at Station PAPA and corresponding data is provided by NOAA PMEL (National Oceanic and Atmospheric Administration Pacific Marine Environmental Laboratory) and is serviced independently of the OOI.

RCA sites are serviced similar to the global arrays, once per year during the summer weather window in the NE Pacific. One maintenance cruise is planned to accommodate the full range of; Shallow and Deep Profiler Moorings, junction boxes (J-Boxes), and instruments that are predicted to require refurbishment and calibration. Not all J-Boxes and instruments are predicted to require annual maintenance (see RCA Sensor Maintenance document), thus each year has a different set of required replacements. All water column instruments, for example, require annual replacement, while seismometers and acoustic instruments are predicted to operate for 3 to 5 years without maintenance. The system has been laid out to reduce ROV operation time. Instruments that require shorter maintenance intervals are fed from co-located J-Boxes, while longer-term instruments are fed from another set of co-located J-Boxes.

4.3.5 Unscheduled Field Operations

Maintenance time within the deployment interval when the ship is proximal to the array is very limited. There is no extra time budgeted and the annual O&M budget does not include unscheduled trips to the arrays except as may be accommodated by re-budgeting of existing activities.

While OOI operates within the constraints of no contingency, no management reserve, and a flat budget, there are methods to gain approval to reallocate funding. Funds can be re-tasked from

underruns when available and approved to recover from a catastrophic failure of any node or platform of the OOI.

The default approach to re-budgeting is for the impacted MIO to re-budget from within, reducing scope as necessary, and subject the plan to review and approval through the Engineering Change Request (ECR) process. The ECR process provides this flexibility in budgeting, while also providing the required NSF review and approval when schedule and/or budget impact threshold values are exceeded as described in the Configuration and Management Plan (CMP), DCN 1000-00000. The PMO and MIOs create ECR's to address these issues.

NSF entertains requests for supplemental funding to meet needs created by special circumstances but does not guarantee supplemental funding. In larger catastrophic cases, there is full program involvement in the decision-making. The decision-making process was established and documented in the OOI 2.0 proposal where "The PI Team share responsibility for decisions that span the Program and reach decisions by consensus." To inform this process, the Program may use a Data-driven Quarterly Review or other means to prioritize assets based on performance metrics and scientific and educational impact.

4.3.6 Array Operations

Mooring / Vehicle Performance – MIO operators carry out routine monitoring of platform power capacity against data collection and mission requirements, quantity and quality of data received (as appropriate), and the command and control of telemetry communications systems. They initiate manual alarms and alerts if system performance appears to be outside the expected range.

Vehicle Piloting and Operations – Perform piloting command and control for vehicle operations (gliders, AUVs).

Alarms, Alerts, Fault, and Incident Reporting – Respond to the receipt of a platform or vehicle alarm, alert, or fault report (these could be initiated automatically or manually and also delivered via automated or manual communications). Respond to the receipt of an Incident Report (such as collision damage, environmental event, mooring drifting from the site, etc.).

Sampling Strategy Updates – Respond to a request to approve an update to a platform or instrument sampling strategy. Implement an approved sampling strategy update.

Real-Time Environmental Event Correlation – Support real-time environmental event correlation through the provision of multiple marine weather feeds, tsunami alarms, ocean observing satellite data, near ship met reports, ice sheet/berg positions, etc. Coordinate platform and vehicle responses to environmental events (via coordination teams performing operations management monitoring).

Data Quality – Real-time automated data quality flags are issued consistent with Quality Assurance / Quality Control of Real-Time Oceanographic Data (QARTOD), along with delayed human-in-the-loop annotations and other manual data quality assessments.

4.3.7 Array Data Telemetry

Data are telemetered to shore throughout each deployment. OOI requires that at least a subset of data from all instruments is telemetered to shore during each deployment. Some data from some instruments are not available until instruments are physically recovered. For example, wave statistics calculated over 20-minute periods are sent to shore hourly, but 1 Hz raw WAVSS data are not telemetered.

4.3.8 RCA Data Flow

4.3.8.1 RCA Data Flow - Core Instruments

RCA instrument data takes a number of parallel pathways to the end user. In each case, data flow from deployed instruments to the RCA shore station in Pacific City, Oregon by two submarine cables deployed on the seafloor. Tier-1 data enters a secure U.S. Navy system, proceeds onwards to the various Object Ring Buffer (ORB), and then to CI's Antelope server. Non-tier-1 data takes two pathways from Pacific City. Raw data travel to the Westin Building Exchange (Westin), an Internet co-location data center, in Seattle, WA via the RCA backhaul (terrestrial fiber operated by Pacific Northwest Gigapop through a partnership with UW-RCA). Data are then routed from the Westin to the University of Washington (UW), where a number of dedicated virtual machines (VM) in the RCA Operations Management Center convert raw data streams into daily raw data files. These files are then copied to CI via a nightly rsync process. The second "set" of non-tier-1 data, call it "streaming data", is intercepted by the Port Agent servers at the shore station. Port Agents collect the data and forward it to the Instrument Drivers where data are parsed, packaged and sent to CI via the QPID message queue. The QPID messages are sent by the backhaul network to CI at the Westin. In addition, port agents for file-based instruments (e.g. ZPLSC and CAMDS) make connections to those instruments and download data files directly. These files are then copied to CI via an rsync process.

4.3.8.2 RCA Data Flow for PI Instruments

Principal Investigator (PI) data flow from instruments connected to RCA submarine infrastructure to the Shore Station in Pacific City Oregon and are then routed over the RCA backhaul to the Westin in Seattle, WA. From the Westin, data flow to dedicated Virtual Machines (VM) running on servers in the RCA Operations Management Center where they are logged and written to a dedicated PI NAS (network-attached storage) device that is isolated from the core OOI CI infrastructure. The VM's are created for individual PI's who, along with RCA engineers, gain access to instrument drivers through PI-dedicated, secure virtual private networks (VPN). PI communication through their VPN is allowed with supervision of RCA personnel. Raw PI data are transferred using rsync (a file transfer utility that operates over secure shell which is a cryptographic network protocol) every 24 hours to the ciw-datahub hosted by CI-OSU. PI data on the RCA PI-NAS are hosted in directories that include readme files generated by the PI's, raw and processed data, and in some cases data products. These data are publicly available through PI pages on the OOI oceanobservatories.org site. The PI pages provide background information about the instruments, the location of instruments, and ftp links to the data and products (PI Web).

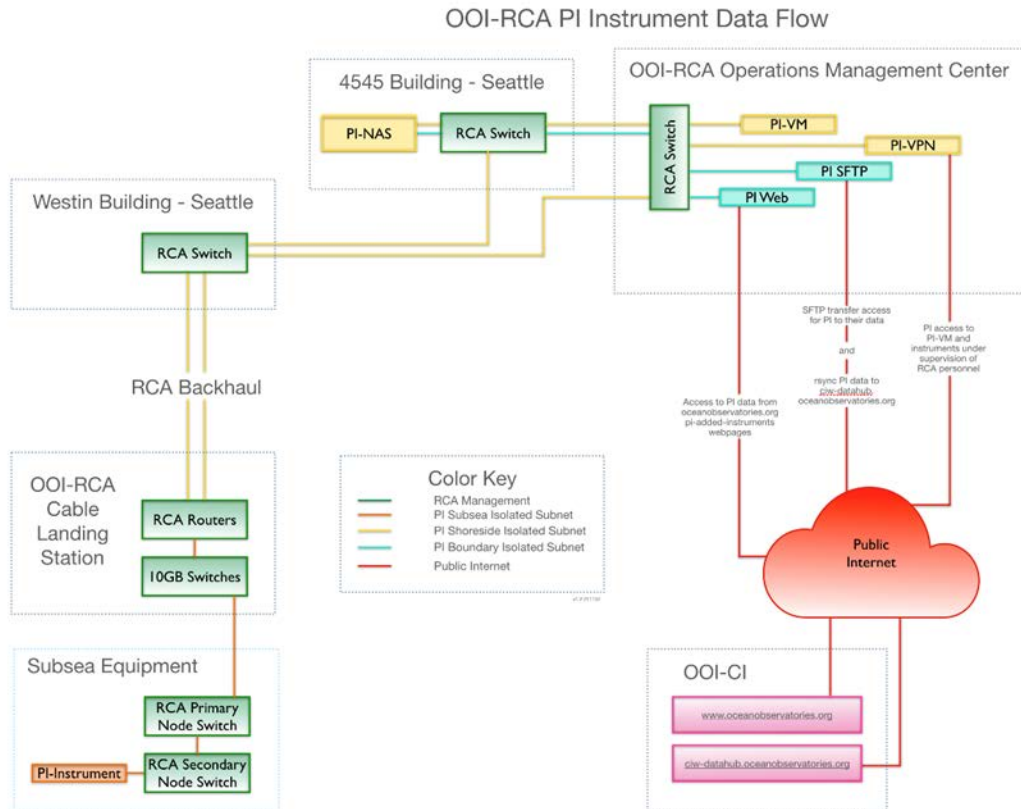

Figure 1: OOI-RCA Data Flow Diagram PI Instruments

4.3.9 CGSN Data Flow

CGSN operates and manages three primary servers: Platform Shore Server, Glider Shore Server, and the Data Server. All three servers are located on the WHOI campus. Data from instruments mounted on the surface and profiler moorings are transmitted via satellite telemetry to the CGSN Platform Shore Server using a proprietary FTP (file transfer protocol) algorithm. AUV data is directly downloaded to the Platform Shore Server following each AUV mission. Gliders transmit data via satellite telemetry to the Glider Shore Server. Gliders are also used to collect or “mule” data from the subsurface moorings located at global array sites. The subsurface mooring data is also collected on the Glider Shore Server. Data for delivery to OOI-CI is consolidated on the Data Server, and rsync’ed (Rsync is a utility for transferring and synchronizing files) via VPN over the public internet to the various OOI-CI managed locations.

Consolidating specific data types across programs is also of interest to the scientific community. CGSN pushes glider and meteorological data to external organizations such as the IOOS Glider Data Assembly Center and National Data Buoy Center.

PI instruments mounted on moorings or mobile assets can be accessed by the PI directly through the OOI webpages, secure ftp access directly to their data, as well as secure posting of the PI data on the raw data server.

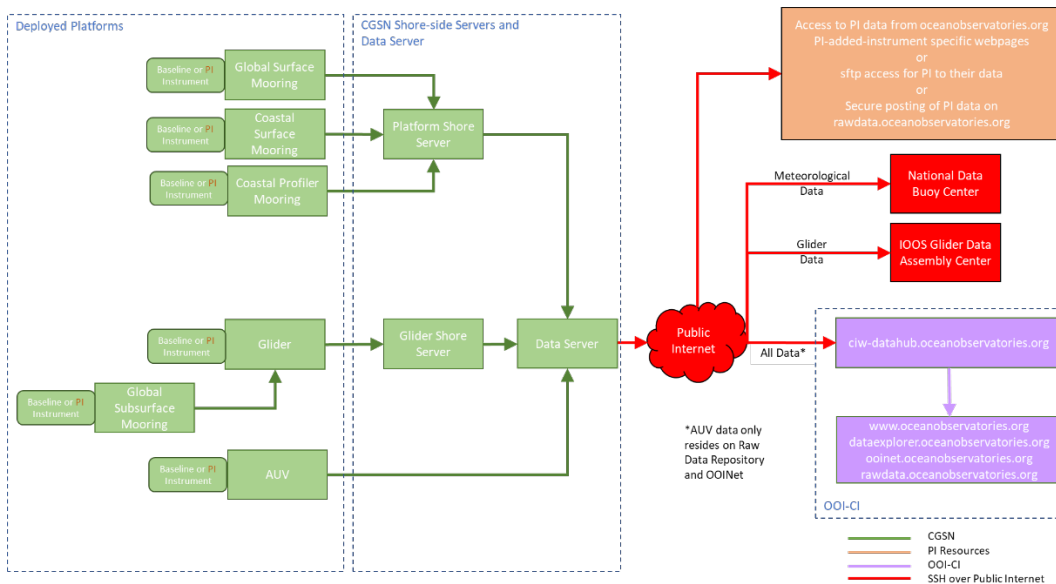

Figure 2: CGSN Data Flow

4.3.10 EA Data Flow

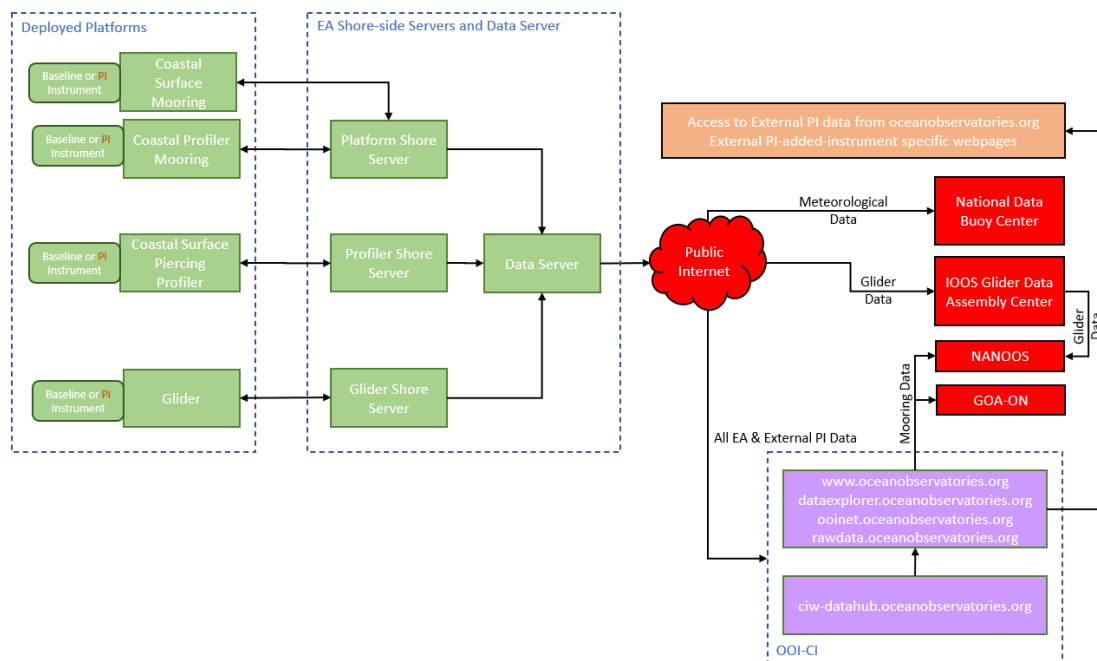

Figure 3: EA Data Flow

4.3.11 Array Post Recovery

Data Recovery Ashore – Instrument and engineering recovered data is downloaded from each instrument and platform if applicable and stored at the MIO operations management hard-wired data ingestion points.

4.3.12 Array General Activities

Other Marine IO general array lifecycle activities include the following:

- Primary Infrastructure performance monitoring and reporting

- Secondary Infrastructure performance monitoring and reporting
- Asset Management
- Incident Reporting
- Training/Certification Records
- Cruise Logs
- PI On-boarding
- Product Improvement / Technical Refresh / Lifecycle Replacement
- Business Continuity / Disaster Recovery

4.4 CI Operations

CI tasks include the following:

- Monitor data status and display to users.
- Monitor system and report status on the overall health of the OSU Data Center (DC) network.
- Execute applications to provide information about application performance and bottlenecks, network and packet transmission throughput, and use of automated Simple Network Management Protocol (SNMP) alerts for sensors, servers, storage, and Wide Area Network (WAN) problems.
- Review new tickets.
- Assign tickets to the responsible person.

Other CI general lifecycle activities include:

- Incident Reporting
- Technical Refresh
- Disaster Recovery
- Data and System Security

4.5 O&M Data Management

The OOI Data Management mission is to develop operational processes for data flow, data product generation, and data product management to ensure that OOI data products meet requirements as per OOI documentation. It includes the following focus areas:

- Stewardship of Data Products Sources: Management and incremental evolution of data product collection procedures to adapt to evolving science needs and technology capabilities and capture of calibration information in the metadata.
- Management of Data Production Processing: Management and incremental evolution of data QA/QC algorithms and procedures, and calibration/validation procedures.

O&M Data Management procedures include updating the following as needed:

- sampling procedures
- metadata procedures
- Data Management Plan
- data product algorithms
- calibration/validation procedures
- data archiving procedures
- data product list

4.6 OOI Trouble Reporting

The IO operations teams utilize the Redmine trouble reporting and resolution system. The IOs are responsible to provide status information on these trouble tickets and ultimately plan and implement corrective action. Internal trouble reports may include those generated during instrument testing and burn-in, during calibration, during field usage, and during post-cruise refurbishment. They may include data quality and record length driven trouble reports generated during analysis and QA/QC of the data at any point, from burn-in to field deployment.

4.7 Data Product Management

The mission of OOI is to deliver near real-time and high-quality oceanographic data and data products to the scientific community. The interconnected network of global, regional, and coastal arrays that characterizes the OOI system provides data streams that span large spatial and temporal scales. The considerable diversity of the OOI data and data products necessitates a well-defined and integrated approach to long-term management to ensure that the data products remain high-quality, easily accessible, and continually responsive to the scientific and educational needs of the community throughout the 25-year lifetime of the OOI network.

The requirement for OOI to provide high-quality and relevant data products to the scientific and non-scientific communities requires that the OOI Data Team consider and incorporate scientific advancements and community needs in their efforts. Recommendations for improvements and access to the OOI data products come from academia, government, and non-governmental agencies, and are considered by the Program.

4.8 Supply Support Management

4.8.1 Spares, Repair Parts, and Consumables

The Supply Support management function for spares, repair parts, and consumables includes the management, actions, procedures, and techniques to determine requirements to acquire, catalog, receive, store, transfer, issue, and dispose of secondary items. The process includes provisioning for initial support, as well as acquiring, distributing, and replenishing inventories. This encompasses provisioning for initial support and all end-to-end replenishment supply support and supply pipeline plans and activities. The Supply Support management function for Replenishment includes the management, actions, procedures, and techniques to determine requirements to acquire, catalog, receive, store, transfer, and issue replenishment items. The process includes provisioning after initial support to maintain pre-established inventory thresholds.

4.8.2 Inventory Tracking

The Inventory tracking function includes the management, actions, procedures, and techniques to efficiently oversee the constant flow of units into and out of an existing inventory. It controls and balances the transfer in of units to prevent the inventory from becoming too high, or so low as to jeopardize the operation of the OOI system. The inventory tracking function controls the costs associated with the inventory, both from the perspective of the total value of the goods included and the tax burden generated by the cumulative value of the inventory.

Inventory tracking balances materials acquisition for inclusion in the total inventory with material use rates and shelf-life for stock. Knowledge of supplier lead times for how long it takes suppliers to process an order and execute delivery and the demand rate for spares and repair parts is essential. This information is recorded in the IO property management systems.

These systems provide an effective inventory management function for provisioning to maintain pre-established inventory thresholds. Items to be tracked may include location, device, vendor, model number, serial number, description, installation date, PO number, warranty information, maintenance costs, and renewal date. An annual audit is conducted to validate that the tracking of the assets is correct. Inventory tracking follows the institutional procedures for government/customer-owned equipment. IO personnel have responsibility to populate, access, and analyze the data in the database. Detailed information related to property management is provided in the OOI Property Management Plan, DCN 1011-00000.

Property Location Tracking: To facilitate logistics planning and to meet the OOI Property Management Plan, the location of material and equipment is tracked in real-time. The history of

the locations is also recorded. Current and historical location/installation data for instruments is included in the metadata.

Asset and Metadata Management: Assets defined as observatory infrastructure components and instrumentation that generate metadata for delivery to CI and cruise metadata utilize a common management tool named Roundabout. Roundabout is a custom database used to deliver asset management information from the MIOs to CI for use within the OOI data delivery system.

Marine Asset Tracking: Instruments are tracked for their entire life cycle including deployed and non-deployed periods. Reference designator locations are matched with instrument serial numbers during particular deployment intervals to completely define the roles of specific instruments over time. CI supports the resource life cycle, tracks calibrations, and captures deployment information such as location in the metadata.

Repair History: Repair history of the property is maintained to assist with logistics planning, as well as to isolate systemic problems (e.g., all instruments of one type are unreliable) and specific problems (e.g., a particular instrument is not reliable). Data QA/QC staff annotate property management records and request consideration of repair action.

Calibration Records: Calibration records are maintained within the property system to facilitate data analysis and to complete the metadata set. Calibration records are accessible to repair and data QA/QC processes.

Spare and Operational Equipment: All serialized equipment purchased is recorded and tracked in the Property Management system.

The Regional Cabled Array (RCA) Material Management Plan (MMP) sets rules, regulations and guidelines for administering a comprehensive logistic operations plan for the RCA. The plan is formulated to achieve the goal of strict compliance to the scope and limitations established by the National Science Foundation (NSF), the Program Management Office (PMO), Ocean Observatories Initiative (OOI) and the University of Washington (UW). The Plan will be used to accurately track the location and other specific information of all RCA purchased items classified as equipment. It will also provide a historical database of RCA equipment for the entire life of the OOI program.

The Material Management Plan covers the overall supply operations, procedures, and management tools needed to fulfill RCA goals and requirements. The plan provides a pro-active approach by:

- Ensuring auditable compliance for all major RCA purchases
- Maintaining visibility of all material financial transactions
- Safeguarding RCA assets for the life of the program

4.8.3 Physical Security

Ensuring the physical security of the OOI is the responsibility of the IOs. For example, the physical security of the wet plant for the RCA is RCA's responsibility. The RCA considered physical security during the design phase, specifically route and burial planning. The RCA participated in community preventive measures by publishing route position lists and communicating with the fishing industry. On-shore facilities are locked and protected from illegal entry and access. The IOs implement security systems or guards. For leased spaces, the OOI infrastructure is contained within a secure discrete and separate facility with monitoring capability, including security and environmental alarms.

MIO hardware on land is maintained in secure storage where appropriate. CI collects and stores data and is responsible for its security. The MIOs provide cyber-security for operations management monitoring and protect the points where telemetered data is collected and passed

to CI, as well as the points where internally recorded data, cruise data, and all ancillary data are collected and passed to CI. The MIOs work with the PMO and NSF to liaise with the communities likely to be at-sea in the regions of nodes and thus mitigate accidental or purposeful damage to the deployed infrastructure. The MIOs also monitor the operation of deployed infrastructure, including tracking its position.

Security is integral to the MIOs on several levels. The team must be concerned about the following: 1) the physical security of the hardware both at-sea, on shore, and in the development laboratories; 2) security of the data that are collected from the observatories; and 3) security of the integrated system. The IOs plan and implement appropriate security throughout the operations and management phase.

Contracts with the Shore Station owners (landlords) are implemented with clear requirements for advance notification of any facility activities that could impact the OOI infrastructure or of any hazardous conditions that might arise. Remote alarms and surveillance for the station are used to ensure security compliance.

4.9 OOI Science User Support Procedures

Because all operations are driven by scientific needs, the MIO operations staff provides direct liaisons with Array Users and technical information to help Users plan for specific projects, including the following:

- Logistics support for pre-deployment planning, movement of hardware and personnel during operation, communications among parties, and safety, security, and environmental guidance.
- Technical support for project planning, including furnishing documentation for system operations, in-water and on-shore systems interfaces, modes of operation, and training of Users in the proper and efficient use of system assets to maximize return on investment.
- Cradle-to-grave resource planning for experiments, including planning stages before mobilization, dry- and wet-side pre-mobilization testing, calibration and qualification, mobilization, deployment, recovery, and demobilization.
- Design planning for the development of observatory compatible instrumentation. Development and provision of standard modules: power supplies, communications, media converters, dry-mate and ROV mate connectors, and extension cables.
- Skilled personnel trained in operational procedures of the system, vessels, rigging, and safe at-sea operations, mechanical, power, and networking functions of the installed infrastructure.

4.9.1 MIO Scientific Investigator Planning

The RCA Team hosts annual calls with externally-funded science investigators to plan the year's field operations, while the CGSN and EA conduct planning meetings as-needed. The goal of the workshop is to update PIs on scheduling, explain science investigator and MIO responsibilities, and discuss ancillary studies that may help provide environmental-physical data of interest during the field programs. The meeting helps build collaboration during the field season and allows science investigators to talk about interdisciplinary studies and potential scheduling conflicts. The MIO Team works closely with NSF, UNOLS, and the PMO to determine the appropriate schedules. A Project Scientist, Staff Scientist, and Engineer have teleconferences with science investigators following the meetings to keep the science investigators updated and to address questions. Checklists are formulated with the science investigator to help communication and to ensure that field operators and scientists are clear on requirements and milestones to meet all science goals.

4.9.2 MIO Project Scientist Team

The MIO Principal Investigator/Project Scientist leads the staff who assist science investigators throughout the proposal stage, and integration and test, deployment, operation, and recovery. In

collaboration with the CI IO, RCA provides a web-based “How To” Manual provides information crucial to proposal preparation (e.g., examples of costs for connectors, cables, and Low Voltage (LV) Nodes, J-Boxes, scheduling updates, and environmental site characterization critical to experimental design, permitting requirements, security and possible user fees). RCA provides an Annual Workshop is held to help inform interested community members on procedures and processes required for the integration of new experiments.

4.9.3 MIO Engineering Team

The MIO Engineering Team includes a Chief/Lead Engineer who oversees the MIO Engineering Team. The Team’s responsibilities include the day-to-day monitoring of the MIO equipment, managing the logistics depots, mobilization and demobilization for all at-sea operations, assisting PIs in the integration of new instruments, and staffing the MIO test laboratories and environmental test facilities.

The MIO Engineering Team and Project Scientists work closely with PIs to guide new experimental designs, flag potential conflicts (e.g., spatial, electromagnetic, acoustics, security, permitting), and help perform additional site surveys if required. The Team works with CI engineering personnel to assist the PI in establishing metadata requirements, installation procedures, and reasonable maintenance schedules. Statements of work with milestones are established and include the following tasks:

- Complete instrument fabrication
- Calibrate instruments
- Complete data acquisition
- Bench test instruments
- Simulate instruments in the infrastructure environment
- Qualify instruments.

The MIO Engineering and CI Teams may be available to provide subcontracting assistance to PIs for their interface designs and fabrication of their instruments if required.

4.10 MIO Quality Assurance / Quality Control

4.10.1 Coastal / Global Scale Nodes and Endurance Array

CGSN and EA QA/QC procedures are defined in the CGSN QA/QC Plan, DCN 3101-00008, and controlled by the CGSN or EA Program Manager. These procedures are modified to maintain the QA/QC integrity of the system as hardware and software changes are made.

4.10.2 Regional Cabled Array

RCA QA/QC procedures are defined in the RCA QA/QC Plan, DCN 4010-00001, and controlled by the RCA Program Manager. These procedures are modified to maintain the QA/QC integrity of the system as hardware and software changes are made.

4.11 OOI Support Facilities

4.11.1 RCA Facilities

The shore-side infrastructure, such as the shore station, data center, and land cables, is maintained by a small, local RCA staff, supplemented by specialized contractors. The Primary Infrastructure requires specialized tools and skills and may be maintained, by a commercial undersea cable maintenance ship. The Secondary Infrastructure is maintained by a UNOLS ship with an ROV.

RCA Shore Station Management:
RCA Shore Station and Outside Plant – Pacific City

The RCA Shore Station is a special-purpose built facility for telecommunications cables located on a 5-acre lot at 33395 Cape Kiwanda Drive in Pacific City, OR. Tillamook Lightwave IGA purchased this facility in 2010. The Colocation and Lease Agreement was modified as of September 1, 2017, to lease 2,751 ft² of space to operate and maintain the OOI terminal station equipment. The services under this agreement provide the physical structure and required support infrastructure for the RCA support and termination equipment that allow the collection of scientific data. The agreement is for an initial term of fifteen (15) years with an option to extend the lease for three (3) additional terms of five (5) years each. RCA shares this facility with the Hawaiki Cable System.

The facility landlord is responsible for maintaining building infrastructure including such items as fire/security, Heating Ventilating and Air Conditioning (HVAC), and emergency generator power.

Outside Plant refers to infrastructure between the shore station and beach manhole, which includes fiber-optic cables, power/conductors, and ducts/sub-ducts. Because this infrastructure is owned by the landlord, he/she maintains contracts with the appropriate vendors to provide services covering the maintenance and repair. These service contracts maintain service level agreements that document the vendor's response time, as well as time to repair various faults.

Power and transmission equipment associated with the wet plant and the backhaul is maintained by the RCA. Planned maintenance activities are conducted by RCA local technicians augmented on an as-needed basis by engineers from the UW Seattle campus. The majority of the planned maintenance can be accomplished by a two-person RCA team located proximate to the shore station. The RCA Oregon team works a normal business day and responds to emergencies outside of normal business hours.

CyberPoP (Cyber Point of Presence) Management:

The CyberPoP, located in the 4545 Building in Seattle, WA, is the interconnection point between the RCA and CI.

Routine preventive maintenance visits are scheduled and completed by RCA personnel.

Backhaul Management:

Managed bandwidth is the lease or purchase of specific units of capacity between specific locations with a defined quality of service. RCA leases two (2) dedicated, diversely routed 10gb/s Ethernet framed network links between Pacific City, OR and Seattle, WA. RCA manages the service provider that is responsible for all maintenance, troubleshooting, and repair of the backhaul.

Wet Plant Management:

Wet Plant Management is divided into Primary and Secondary Infrastructure. The two categories are differentiated based on the type of maintenance tools as well as the complexity of the infrastructure.

Primary Infrastructure Management:

The Primary infrastructure is the cable and components starting at the beach manhole and extending seaward to the Primary Nodes. Except for the Nodes themselves, all components are commercial off-the-shelf products of the undersea cable industry. Based on the specialized equipment required to properly install and repair these cables, wet repairs are conducted by a traditional cable ship. This cable ship would be dynamically positioned supported by a highly accurate navigation system and equipped with specialized cable-laying machinery; as well as an ROV capable of assisting in cable recovery and reburial in water depths from 15 –1,500 meters for shallow work, and up to 3,000m for the deeper, unburied cable and Primary Nodes.

RCA primary infrastructure spares are stored in Seattle, WA, and Portland, OR.

In the event of a fault in the Primary Infrastructure, RCA Management reviews the data from the Network Management System (NMS) and determines the service impacts of the fault. Analysis of the service impacts determines the immediacy of the repair response. Some undersea infrastructures have continued to operate for long periods despite a fault condition, so a rush to repair is not always prudent. Close coordination with the CI is required to keep the User Community aware of the Infrastructure status. In the event of a complete loss of service, technicians are dispatched to the shore station for electrical and optical isolation of the fault. In the event of diminished service, coordination takes place with the User Community to ensure that no critical experiments are taking place, at which time intrusive testing takes place to identify and isolate the fault. After careful evaluation of the fault and determination that a repair is required, an appropriate repair window is identified. The repair window is selected based on events such as cable ship availability, upcoming experiments, and infrastructure maintenance schedule, as well as budget.

At-sea repair operations of the Primary Infrastructure are led by the cable ship's Engineer in Charge. The RCA has at least one technical representative onboard to act as the Owner's representative. The cable ship coordinates all activities directly with RCA personnel located in the shore station.

Secondary Infrastructure Management:

RCA uses a UNOLS Global class research ship with an ROV (Jason) for the maintenance and repair of the Secondary Infrastructure.

A maintenance cruise for the RCA Secondary Infrastructure is planned each year. Based on the sea-keeping abilities of the UNOLS Global class, and the expected weather conditions, the maintenance cruise is scheduled during the late spring to early fall.

The RCA applies an Annual Management Plan for the Secondary Infrastructure. The plan draws upon planned maintenance intervals of the specific infrastructure and emergent failures or abnormalities. The RCA submits a prioritized maintenance plan to the Observatory Operations Team for endorsement. In some instances, based on financial or operational requirements, the entire maintenance plan may not be accomplished and activities roll to the next year's plan.

During at-sea operations the RCA Operations Director and shipboard Engineer/Scientist-in-Charge are given latitude to adapt to field conditions based on predetermined maintenance philosophies developed in conjunction with the RCA Observatory Operations Team.

Secondary Infrastructure spares are maintained at facilities in Seattle, WA. The facilities provide environmentally controlled inside storage. A temporary logistics facility is established annually to support the maintenance cruise. This facility provides environmentally controlled inside storage and outside storage capability and is proximate to piers that at a minimum can accommodate an UNOLS Global Class research ship.

RCA uses the OOI-RCA Secondary Infrastructure Spares Plan to detail the plans for the acquisition of redundant and spare Secondary Infrastructure including the LV Node, J-Boxes, Vertical Mooring, Deep and Shallow Profilers, and associated spare equipment. In addition, RCA has developed the OOI-RCA Sensor Maintenance, Risk, and Replacement document to detail the plans for acquisition of redundant and spare instruments on the RCA and associated FTEs for maintenance and QA of the instruments. Both documents are referenced in Appendix B.

4.11.2 CGSN Facilities

Facilities available to the OOI at WHOI include dedicated space and capabilities in two buildings. Dedicated space in the Laboratory for Ocean Sensors and Observing Systems (LOSOS) building includes a 10,000 square-foot high bay with storage racks, a 10-ton 19-foot capacity crane, an inventory control cage, a 2000 square-foot Wet and Dry Lab, an Instrument Lab with freshwater test tank and overhead crane, a Glider Lab with seawater ballast tank and overhead cranes; an

Operations Control Room, and a 2000 square-foot Electrical Engineering Lab. Dedicated outside facilities at LOSOS include 20,000 square feet of paved staging and storage space, three 1200-gallon salt-water filtered tanks for instrument integration and testing, one 1200-gallon fresh-water filtered tank for instrument rinsing, one 6000-pound capacity fork truck, and eight 20-foot side loading storage containers. Dedicated inside space at LOSOS North building includes a 5,000 square-foot high bay with a one-ton overhead crane, an Inventory and Cruise Kit Control Space, a 650 square-foot AUV Storage and Refurbishment Lab with a 1200-gallon salt-water filtered tank, a wet area for instrument cleaning and post cruise operations, and a 2000 square-foot Mechanical and Electrical Lab.

Facilities available to the OOI at WHOI also include shared space and capabilities. Shared space in the Coastal Research Lab (CRL) includes a 10,000 square-foot high bay with storage racks, a 10-ton 17-foot capacity crane, 10,000 square feet of paved staging and storage space, 6,000- and 25,000-pound capacity fork trucks, and a 17,000-gallon salt-water filtered tank for buoyancy adjustments and instrument testing.

The shared Shipping & Receiving and Warehouse facilities include a 50,000 square-foot warehouse, three 6,000-pound and one 35,000-pound capacity fork trucks, and a loading dock. The Smith Building near the WHOI Dock houses the Rigging Shop and has 50-ton 30-foot capacity overhead crane, two 6,000-pound capacity fork trucks, a 150,000-pound capacity horizontal pull-test machine, a 75,000-pound capacity horizontal pull-test machine. The Iselin Marine Facility (IMF) serves as a port for the two UNOLS and other WHOI vessels, and as an away port for vessels from other institutions, with dock space sufficient for loading and unloading containerized shipments. The IMF provides dockside carpentry, mechanical, electrical, welding and machine shop services; hangar bays for indoor staging of large platforms and instruments; test wells, five-ton and 25-ton bridge cranes; and other vehicles including forklifts and flatbed trucks. WHOI provides wire winding services funded through NSF and other services that may be used for winch support.

4.11.3 EA Facilities

OSU has two main facilities to support OOI refurbishment and cruise operations. Refurbishment occurs at the Ocean Observing Center (OOC), at the OSU Campus in Corvallis, Oregon. Cruise operations are staged from the OSU Ship Operations Facility, located in Newport, Oregon.

The OOC is a 12,500 square-foot building with 28-foot ceilings. Each of the interior areas is equipped with the tools, test equipment, work surfaces, storage and computers needed to perform refurbishment, test components, and document status. The OOC interior space includes a 3000 square-foot High Bay with a five-ton overhead crane and truck loading bays, a 950 square-foot Glider Lab with a 2,000-gallon tank for testing and ballasting, a 750 square-foot Profiler Lab, a 950 square-foot Platform Lab, a 600 square-foot Electronics Lab, a 400 square-foot Machine Shop, a 300 square-foot capability for Shipping & Receiving, a 3,000 square-foot Upper Storage Mezzanine, and 2,400 square feet of office space.

The OOC exterior space includes a 40,000 square-foot paved, lighted and fenced staging and storage facility surrounding the building, covered working and storage areas, power and water at multiple locations, and 6,000-pound and 25,000-pound capacity forklifts. The OOC has a fiber connection to the College of Earth, Ocean and Atmospheric Science (CEOAS) Computing Center, which provides servers that are protected and backed up by continuous uninterruptible power.

The Ship Operations Facility in Newport provides equipment and space for truck loading and offloading, assembly, testing, emergency repairs, and temporary storage. The wharf supports the Global Class UNOLS vessels that are needed to maintain the OOI; provides pier space for final assembly and testing of OOI platforms; and provides 4,000-pound, 10,000-pound and 30,000-pound capacity forklifts and an 18-ton 65-foot capacity crane.

Appendix A: Acronyms

APL	Applied Physics Laboratory
ASIMET	Air-Sea Interaction Meteorology
AUV	Autonomous Underwater Vehicle
AWP	Annual Work Plan
BOE	Basis of Estimate
CCB	Change Control Board
CEP	Community Engagement Plan
CFR	Code of Federal Regulations
CGSN	Coastal/Global Scale Nodes
CI	Cyberinfrastructure
CM	Configuration Management
CMP	Configuration Management Plan
CONOPS	Concept of Operations
COTS	Commercial Off The Shelf
CSPP	Coastal Surface Piercing Profiler
CTD	Conductivity, Temperature, Depth
DCL	Data Concentrator Logger
DCN	Document Control Number
DISA	Defense Information Systems Agency
DPL	Data Product List
DMP	Data Management Plan
DMOQ	Direct Measurements Of Quality
EH&S	Environmental Health and Safety
FTE	Full Time Equivalent
IO	Implementing Organization
ION	Integrated Observatory Network
IRR	Installation Readiness Review
J-Box	Junction box
LVN	Low Voltage Node
MFN	Multi-Function Node
MIO	Marine Implementing Organization
NEPA	National Environmental Policy Act
NIST	National Institute of Standards and Technology
NMS	Network Management System
NOAA	National Oceanic and Atmospheric Administration
NSF	National Science Foundation
O&M	Operations and Management
OCE	Division of Ocean Sciences
OEM	Original Equipment Manufacturer
OMS	Observatory Management System
OSU	Oregon State University
PDR	Preliminary Design Review
PI	Principal Investigator
PM	Program or Project Manager
PMEL	Pacific Marine Environmental Laboratory
PMO	Program Management Office
PS	Project Scientist
QA	Quality Assurance

QA/QC	Quality Assurance/Quality Control
QARTOD	Quality Assurance / Quality Control of Real-Time Oceanographic Data
QC	Quality Control
ROV	Remotely Operated Vehicle
RCA	Regional Cabled Array
RVSS	Research Vessel Safety Standards
SE	Systems Engineer
SLA	Service Level Agreement
SNMP	Simple Network Management Protocol
TDP	Technical Data Package
UNOLS	University-National Oceanographic Laboratory System
UW	University of Washington
WAN	Wide Area Network
WBS	Work Breakdown Structure
WHOI	Woods Hole Oceanographic Institution

Appendix B: Reference Documents

Document No.	Document Title
1000-00000	OOI Configuration Management Plan
1001-00000	OOI Project Execution Plan
1003-00000	OOI Quality Assurance Plan
1001-00001	OOI Environmental Compliance and Permit Plan
1006-00000	OOI Environmental Health and Safety Plan
1007-00000	Risk and Opportunity Management Plan
1011-00000	OOI Property Management Plan
1012-00000	CI Cybersecurity Plan
1060-00000	Community Engagement Plan
1100-00000	OOI Systems Engineering Management Plan
1102-00000	OOI Data Management Plan
1102-00010	OOI Data Use Policy
1102-00020	OOI Data User Terms and Conditions
1100-00007	OOI Instrument Tech Refresh
1141-00001	OOI Commissioning Report
1145-00001	OOI Validation Report
3101-00008	CGSN Quality Assurance Plan
3101-00009	CGSN Environmental Health and Safety Plan
3201-00007	CGSN Site Characterization: Southern Ocean Array
3202-00007	CGSN Site Characterization: Irminger Sea Array
3203-00007	CGSN Site Characterization: Station Papa Array
3204-00007	CGSN Site Characterization: Pioneer Array
3205-00007	CGSN Site Characterization: Endurance Array
3206-00007	CGSN Site Characterization: Argentine Basin Array
4010-00001	RCA Quality Assurance and Quality Control Plan
4011-00001	RCA Environmental Health and Safety Plan
4015-00001	RCA Property Management Plan
4308-00005	OOI-RCA Sensor Maintenance, Risk, and Replacement
4314-00001	OOI-RCA Secondary Infrastructure Spares Plan
4315-00001	RCA Installation Planning Scenarios – Hydrate Ridge
4316-00001	RCA Fouling of Instruments and Infrastructure
4318-00001	Remotely Operated Vehicle (ROV) Strategy White Paper

